

**IMPERIAL METALS CORPORATION
MT. POLLEY PROJECT**

**RESPONSE TO REVIEW COMMENTS
ON TAILINGS EMBANKMENT DESIGN
(REF. NO. 1625/6)**

JANUARY 25, 1996

MP00005

*Suite 1400
750 West Pender Street
Vancouver, British Columbia
Canada V6C 2T8
Telephone (604) 685-0543
Telefax (604) 685-0147
CIS: 72360,477*

Knight Piésold Ltd.
CONSULTING ENGINEERS

GRIT 2250

IMPERIAL METALS CORPORATION
MT. POLLEY PROJECT

RESPONSE TO REVIEW COMMENTS
ON TAILINGS EMBANKMENT DESIGN
(REF. NO. 1625/6)

TABLE OF CONTENTS

	<u>PAGE</u>
SECTION 1.0 INTRODUCTION	1
SECTION 2.0 RESPONSES	2
SECTION 3.0 CLOSING COMMENTS	13

FIGURES

Figure 1	Tailings Gradation
Figure 2	Relationship Between Compaction Energy and Moisture Content - Density
Figure 3	Tension Crack Stability Analyses

DRAWINGS

1623.103 Rev 0	Tailings Storage Facility - Geological Cross-Sections
1625.111 Rev 1	Tailings Storage Facility - Tailings Embankment - Sections and Details
1625.202 Rev 2	Tailings Storage Facility - Foundation Preparation and Basin Liner - Sections and Details
1625.205 Rev 2	Tailings Storage Facility - Stage Ib Tailings Impoundment - General Arrangement



- 1625.212 Rev 0 Tailings Storage Facility - Material Specifications
- 1625.220 Rev 2 Tailings Storage Facility - Instrumentation Plan
- 1625.221 Rev 1 Tailings Storage Facility - Instrumentation Sections and Details

APPENDICES

Appendix A Test Pit Logs From 1995 Supplementary Investigations



IMPERIAL METALS CORPORATION
MT. POLLEY PROJECT

RESPONSE TO REVIEW COMMENTS
ON TAILINGS EMBANKMENT DESIGN
(REF. NO. 1625/6)

SECTION 1.0 - INTRODUCTION

We are pleased to provide the following responses to the comments made by Mr. C.O. Brawner with respect to his review of the Mt. Polley Tailings Embankment design. Several of the points raised by Mr. Brawner have previously been discussed with Mr. G. Headley of the Ministry of Energy Mines and Petroleum Resources (MEMPR) - Geotechnical Division and have already been included in the detailed design drawings and technical specifications which may not have been made available for Mr. Brawner's review.



*YH
Comments*

SECTION 2.0 - RESPONSES

Mr. Brawner's comments are presented in *italics* and are discussed in the order of his presentation.

General

The plan is to develop three pits. From environmental, volume storage and tailings dam height considerations it is recommended that Imperial Metals be requested to review in detail the potential to mine the pit sequentially and place tailings in them on completion of Pit 1 followed by Pit 2. The stability and environmental benefits are significant. There may also be a cost saving.

*Yes, review
in 5 yrs. tab
time of mining
permitted
pits*

The Mt. Polley deposit is a complicated ore body which requires mining from all three pits at various times in order to optimize grade and recovery. The mine plan is being developed by Imperial Metals Mine Engineering staff who are considering various development and waste storage options including in-pit storage of waste and possibly tailings. Knight Piésold consider in-pit tailings disposal to be a viable concept, but this should only be evaluated later on in the mine life, once the open pit development schedule is well defined. Therefore, in-pit tailings disposal is considered to be a possible opportunity for future mine development. We feel it is conservative to ignore this possible option at the present time and continue to plan for secure surface disposal of all tailings solids.

Site Investigation

Only one drill hole appears to have been drilled in the main embankment area. In B.C. valleys there is always the possibility of buried high permeability zones. It is recommended that 2 more boreholes to expand the geotechnical information be drilled and tested.

One hole has been drilled in the Main Embankment area (MP89-234), as noted by Mr. Brawner. It has previously been discussed with Mr. Headley (MEMPR) and it was agreed that three additional holes will be drilled, logged and sampled by a geotechnical engineer during the initial stages of construction as part of the embankment instrumentation and monitoring requirements. The holes are specified in



the Technical Specifications and shown on Drawing Nos. 510-77-01-1625.220 and 1625.221. They will be drilled to about 15m depth and will be located in the bottom of the main valley, where significant overburden is known to be present. Lab testing will be conducted on the samples as required and vibrating wire piezometers will be installed in the embankment foundation for long term water pressure monitoring.

Glaciofluvial Sediments in the Tailings Basin

It is noted that obtaining good compaction and density of the till liner over the sediments will be difficult due to poor underlying support of the sediments.

Has removal of the sediments been considered so the liner is not required?

We do not consider total removal of the sediments to be a viable option, as these materials are suspected to underlie the dense low permeability glacial till within the basin. The glacial till materials were deposited when a glacier extended over the area, and it was this glaciation which caused the heavily over consolidated nature of the underlying sediments. Therefore, the basin liner is merely an extension of this natural low permeability glacial till cover and is only required in those areas where the natural glacial till deposit has been removed by recent surface erosion which has locally exposed the glaciolacustrine sequence in the vicinity of the proposed embankment and further downstream.

In early October, 1995, a total of 34 additional test pits were excavated and logged at the Main Embankment area. In addition, 6 test pits were excavated and logged at the Seepage Collection Pond area. This information has previously been submitted to Mr. Headley (MEMPR, Geotechnical Branch) and is included in Appendix A. The investigations are summarized below :

- The test pits were typically 6 m deep.
- Test pit excavations started in the centre of the valley and progressed toward the left (east) abutment at 25 m centres. These test pits encountered 2 to 3 m of dense, moist to wet till overlying stiff to very stiff, overconsolidated silt



and silty sand (glaciolacustrine sediments). No sections of loose wet sediments were identified.

- Test pits were then excavated progressively toward the right (west) abutment at a 25 m spacing. Similar stratigraphy was encountered for approx. 125 m. At TPME-15 loose wet sand was encountered below the till. This material extended on the embankment centreline for approx. 125 m, to TPME-20. Over this area, the till cap varied from 1.7 m to 3 m thick, with loose glaciofluvial sediments underlying the till. At the upstream toe of the embankment this zone was approx. 100 m wide. It was approximately 130 m wide at the Stage Ib and Final downstream toe locations.
- The test pits excavated at the Seepage Collection Pond area were required to define the limits of the fine till and glaciolacustrine sediments in which the pond could easily be excavated. It was found that only the southwest corner was underlain by loose sediments. The rest of the pond has stiff silt and silty sand (glaciolacustrine sediments) below a till cap. Both of these materials are suitable for excavation of the pond. The pond will be relocated to avoid construction in any area with loose sediments.

Mr. Brawner has indicated that placement and compaction of the till basin liner will be difficult because of poor underlying support of the sediments and he has suggested that consideration should be given to removing the sediments. However, the test pit excavations have shown that the underlying highly overconsolidated sediments have sufficient strength characteristics to allow placement and compaction of the liner provided that all loose, wet topsoil and glacial till at the topsoil/till contact (a maximum of about 30 cm) is removed prior to fill placement. We feel that it will not be difficult to obtain good compaction and density of the basin liner and do not consider that total removal of the sediments will be necessary. In fact, the additional site investigations have indicated that the extent of the basin liner can be reduced in area due to the excellent low permeability foundation materials encountered throughout most of the tailings basin.



If the liner is placed it is suggested that a seepage cut-off be excavated and backfilled through the sediments near the upstream toe of the main embankment.

The nature and distribution of the geologic units, as described above and as shown on Drawing No. 1623.103, illustrate that it would be extremely difficult to construct a seepage cut-off at the upstream toe of the Main Embankment. In order for the cut-off wall to be effective, it must be extended to low permeability materials both vertically and laterally or else the seepage losses will merely be redirected to a different direction. Therefore, the seepage cut-off would have to be extended completely along the West Embankment. The seepage cut-off wall would be extremely difficult to construct and it is unlikely that it would provide any additional benefit and could actually result in a less efficient seepage control measures than the currently designed system.

Excavate all weak soil to at least 10 m upstream of the upstream toe of the main dam.

Any weak soils which could adversely affect construction activities, embankment stability or could compromise the efficiency of the seepage control measures will be removed and/or treated as specified in the Technical Specifications and as required by the Knight Piésold supervising engineers.

Underdrains

The design of all drain pipe must have sufficient strength to resist full earth load.

All drain lines that exit the dams must be designed so they can be cleaned for distances of about 100 m.

All culverts and drain lines must be designed or protected from icing up in the winter.

The design of the embankment drainage pipeworks is illustrated on Drawing No. 510-14-03-1625.202. The drainage pipeworks consist of CPE embankment foundation drains and DR17 HDPE pipework for the toe drains which pass through the



abutments at the Main Embankment. The perforated CPE foundation drains are not required to resist full earth loads as the drains include a gravel surround which provides contingency flow capacity. The HDPE toe drains pass below the core zone and have been designed to withstand full earth loads from the ultimate embankment. The HDPE drains could be cleaned out as recommended by Mr Brawner, and additional toe drains can also be installed during future embankment raises, if necessary.

A series of perforated CPE drain pipes surrounded by gravel and filter fabric were previously included for control of groundwater during construction of the partial basin liner and for long term monitoring. However, the additional site investigation test pits described above and in Appendix A, indicate that the extent of the constructed basin liner will be reduced and the comprehensive drainage network will not be required. Therefore, the basin groundwater drains have been removed from the current Detailed Design Drawings.

All embankment drainage pipes will be covered by a minimum of 1 m of soil to prevent freezing. Buried pipeworks downstream of the embankment also include a cover berm, both for protection from icing and for easy identification and location of the pipes. The outlet pipeworks discharge to a covered drainage sump prior to discharge below the water (or ice) surface of the seepage collection pond.

Sediment control pipeworks, culverts and flow control structures associated with other components of the tailings storage facility also include standard provisions for cold weather operations.

Seepage Collection Pond

In the event that Imperial Metals may find more ore and tailings volume increases, the dam should only be increased in height by the downstream method. To allow for this the seepage collection pond should be located so such change will not encroach on the pond.

The design currently incorporates a buffer zone of approximately 35 m immediately downstream of the toe of the final embankment limits. The storage capacity of the



tailings impoundment could be easily expanded to accommodate over 30 million additional tonnes of tailings by raising the final embankment crest by about 17 m using the centreline construction method. Furthermore, it would be a relatively simple exercise to relocate the seepage collection pond further downstream to provide additional space for further extension of the downstream toe of the embankment should this be necessary in the future.

Filter Design

Filter gradation is required to be shown. The design must be conservative.

Filter gradations for construction materials are shown on Drawing No. 510-14-03-1625.212, which is taken from part of the Technical Specifications. The gradation of the tailings is shown on Figure 1 (from Tailings Storage Facility Design Report, Ref. No. 1625/1, May 26, 1995).

The filter materials are considered to be 'non-critical' as defined by Sherard et al (Sherard, J.L., Dunnigan, L.P. and Talbot, J.R., 1984. "Filters For Silts and Clays", ASCE Journal of Geotechnical Engineering, Vol. 110, No. GT6), as they are situated upstream of the core zone. However, the specified filter gradations have been conservatively designed to meet the more rigorous criteria for 'critical' filters. Therefore, the specified filter gradations meet or exceed conventional filter requirements for both the glacial till core zone and for the tailings solids.

Index tests on the bulk tailings sample shown on Figure 1 indicate that the material is non-plastic and fine grained, with 6 percent clay, 64 percent silt and 30 percent fine sand. The operations of the tailings spigotting system will lead to some separation of the tailings adjacent to the embankment, whereby coarser materials will settle out rapidly and finer materials will be transported further out into the pond. The result is that additional filter relationships will be developed between the fine and coarse tailings as well as between the coarser tailings and embankment fill materials. In the event that cracks develop on the embankment from the upstream side, it is anticipated that the tailings will also function as a crack stopping filter medium.



Random Fill

Provide the range of acceptable gradation.

Gradation envelopes for embankment fill materials are also included on Drawing No. 510-14-03-1625.212.

Compaction

Substantial direction is made to the use of vibrating compactors. This method usually develops a moisture profile in the lift and brings fines to the surface. Whenever vibrating compactors are used the surface must be scarified prior to placing the next lift.

Where soils to be compacted contain a moderate clay fraction it is better to use a heavy grid or club foot compactor. The grid roller is the most versatile, being suitable to all soil and gradations and can be pulled at a faster speed than other types for equivalent density.

We disagree with Mr. Brawner's comments about vibrating compactors and we have specified in the Technical Specifications that a self-propelled 10 ton (minimum) vibratory wedge foot roller be used to compact the glacial till. This compactor is excellent for glacial till as it combines the kneading properties of a sheep's foot (or club foot) roller with the high compactive energy provided by a vibratory roller. The wedge foot compactor leaves a rough, pitted surface which does not require scarification. Vibratory rollers can produce a "moisture profile" when operating on materials that are significantly wet of the optimum moisture content. However, it is intended that any materials which are so wet as to interfere with proper compaction will not be permitted. The specified wedge foot roller could be operated in the static mode (no vibration) if wet materials were approved for placement in the embankment fill zones. Moisture Content - Density relationships for compaction equipment are discussed further under *Compaction Tests* below.



Groundwater Monitoring Wells

Provide the location of these wells. Several must be downstream. List test requirements.

Three permanent groundwater quality monitoring wells have been specified in the detailed design of the Tailings Storage Facility. The locations are shown on Drawing No. 510-12-02-1625.205. Additional monitoring wells will be installed as required during operations and as outlined in "Groundwater Monitoring Design Document" (Knight Piésold Ltd. Ref. No. 1625/5, May 19,1995).

All monitoring wells will be installed in accordance with the industry standards and regulatory requirements, including proper well development and regular sampling and testing. The installation and monitoring requirements are also described in detail in "Groundwater Monitoring Design Document" (Knight Piésold Ltd. Ref. No. 1625/5, May 19,1995).

Compaction Tests

Why is Modified Proctor density used as the reference? Standard Proctor density is more common. A higher moisture content can be tolerated with Standard Proctor criteria. Over-compaction results in a brittle dam structure with limited flexibility to deal with differential settlement.

Mr. Brawner's statements reflect a common misconception within the earthworks construction industry. As indicated on Figure 1, there are different moisture-density relationships depending on the level of compactive effort applied. The Standard Proctor energy is lower than for the Modified Proctor test and, for the given example, the machine compaction energy is still higher.

It is evident from Figure 2 that if one only considers the individual test results, the 'maximum' density decreases as the compaction effort is reduced, and the 'optimum' moisture content also increases as the compactive effort is reduced. However, the theoretical moisture content - density relationship for a soil is defined by the zero air voids line, but we generally find that the 2% air voids line is usually the control in practice. Consequently, if the Standard Proctor moisture density criteria are



specified, a lower density fill with a higher permeability and greater compressibility can result. Also, if the contractor attempts to place the fill at the standard proctor optimum moisture content with the heavier compaction equipment, he will sometimes find that excessive rutting, weaving and pore pressure development (or moisture profiles) can occur in fine grained soils. Knight Piésold have therefore used the Modified Proctor test as the reference as it provides a moisture - density relationship which is closer to the relationship expected from the specified compaction equipment.

The glacial till has a fairly low plasticity ($PI = 10$ to 14) and will be placed at near the optimum moisture content as defined by the Modified Proctor test. Placement at a higher moisture content and a lower density as suggested by Mr. Brawner would result in larger post construction fill settlements and would increase the likelihood of cracks forming in the fill.

Seepage Collection Pond Dam

Consider a low permeability cut-off under the dam.

The seepage collection pond will be constructed by excavation into low permeability glacial till and overconsolidated sediments and does not include a dam. The level of the pond will be maintained below the natural groundwater level and, therefore surrounding groundwater migrates toward the pond creating a hydraulic sink. This will prevent seepage losses downgradient. The Bootjack-Morehead connector road includes a small amount of fill for road subgrade immediately below the seepage collection pond, but is not intended to be a dam. A low permeability cut-off would not provide any additional benefit as discussed previously in "*Glaciofluvial Sediments in the Tailings Basin*".

Stockpile Stabilisation Materials for Urgent Use

Develop stockpiles of artificial membranes, filter cloth, short horizontal drains, filter materials, sand bags etc., for use if unexpected events occur such as:

- ***dam overflow control if massive precipitation or runoff occurs;***
- ***pipng or seepage control from the dam slope, toe or valley floor develops;***
- ***tension cracks develop in the dam.***



The design basis for the tailings impoundment includes provisions for storage of the total runoff from the Probable Maximum Precipitation event. Also, the tailings facility will be carefully designed, constructed and closely monitored during initial construction and over its lifetime. If any problems are identified during the course of construction or ongoing monitoring, appropriate remedial actions, contingency plans and materials stockpiles will be implemented.

Modified Centreline Design

The design proposed entails some of the compacted main dam to be constructed over loose to medium dense tailings. With this design variability in consolidation characteristics would be expected. This could lead to tension cracks near the top of the main dam and generally parallel to C.L. Stability analysis should allow for 10 m deep tension cracks filled with water.

Vibratory compaction of the beach should also be considered for the beach zone in the zone downstream of the S.O.L. to ensure low compressibility results.

The modified centreline construction method is illustrated on Drawing 1625.111. As in the centreline construction method, the embankment fill zones extend onto the tailings beaches during each staged expansion. The tailings beaches will be comprised of sandy materials with a very high coefficient of consolidation. The compressibility of these materials will also be low and any settlements which result from on-going expansion of the embankment occur relatively rapidly and are complete during the construction period. In fact, one of the design requirements for each of the staged expansions on to the tailings beaches is for monitoring with vibrating wire piezometers in order to identify the development and dissipation of any excess pore pressures during construction. It has been our experience that any excess pore pressures which develop in the tailings tend to dissipate relatively quickly and the technical specifications include provisions for monitoring to ensure that the pore pressures have dissipated (and consolidation is therefore completed) prior to placement of each successive lift. Vibratory compaction of the first lift typically results in the largest pore pressure response in saturated tailings, after which successive lifts show progressively lower response to loading. The compressibility of the tailings decreases in response to the densification which results from loading and



compaction so that compression of the tailings during future staged expansions will not be significant.

Based on our experience with similar construction methods and comparable tailings materials, it is highly unlikely that 10 m deep tension cracks can develop along the crest of the embankment. However, as suggested by Mr. Brawner, stability analyses have been conducted for a 10 m deep tension crack filled with water, as shown on Figure 3. The factor of safety for the water filled tension crack is higher than for the previously reported stability analyses. Therefore, the previously reported minimum factors of safety for the tailings embankment are unchanged even if a 10 m water filled tension crack occurs.

An upstream slip surface for a 10 m water filled tension crack was also evaluated. The results showed that this case is also not critical as the factor of safety is well in excess of 1.5.

Winter Operation

Describe winter operation for disposal.

The supernatant pond is expected to freeze and an ice cover of up to about 500 mm may result. This is a common occurrence for tailings impoundments situated in cold climates, and tailings sedimentation and process water reclaim will continue virtually unaffected by the ice cover. The primary consideration for winter operations is related to tailings deposition by spigotting during extreme cold conditions. The tailings discharge pipeworks will be managed in order to prevent low flows from freezing and glaciating which would result in large volumes of ice becoming entrapped within the tailings mass. Based on our experience at other cold regions tailings disposal operations, we do not feel that winter operations will be particularly difficult at the Mt. Polley site and the only modifications to the summer operating procedures would likely be the operation of fewer spigots in order to concentrate the tailings flows and thus prevent glaciating of the tailings discharge streams.



SECTION 3.0 - CLOSING COMMENTS

In order to ensure that the above listed concerns and all other design objectives are met, all construction activities will be monitored by Knight Piésold geotechnical engineers. As part of the construction supervision program, a detailed Quality Assurance/Quality Control (QA/QC) program will be implemented. The QA/QC program will include Control Tests required for approval of construction materials and Record Tests on placed and compacted materials.

The tailings storage facility has been designed for staged construction over the life of the mine. This allows the on-going performance of the facility to be continually evaluated. The design has flexibility and can be revised as required based on monitoring records, operating experience and updated mine planning.



KNIGHT AND PIESOLD LTD.
CONSULTING ENGINEERS

UNIFIED SOIL CLASSIFICATION SYSTEM

PROJECT No. 1621
SAMPLE No. _____
DATE _____

PROJECT : *MT. POLLEY TAILINGS GRADATION*

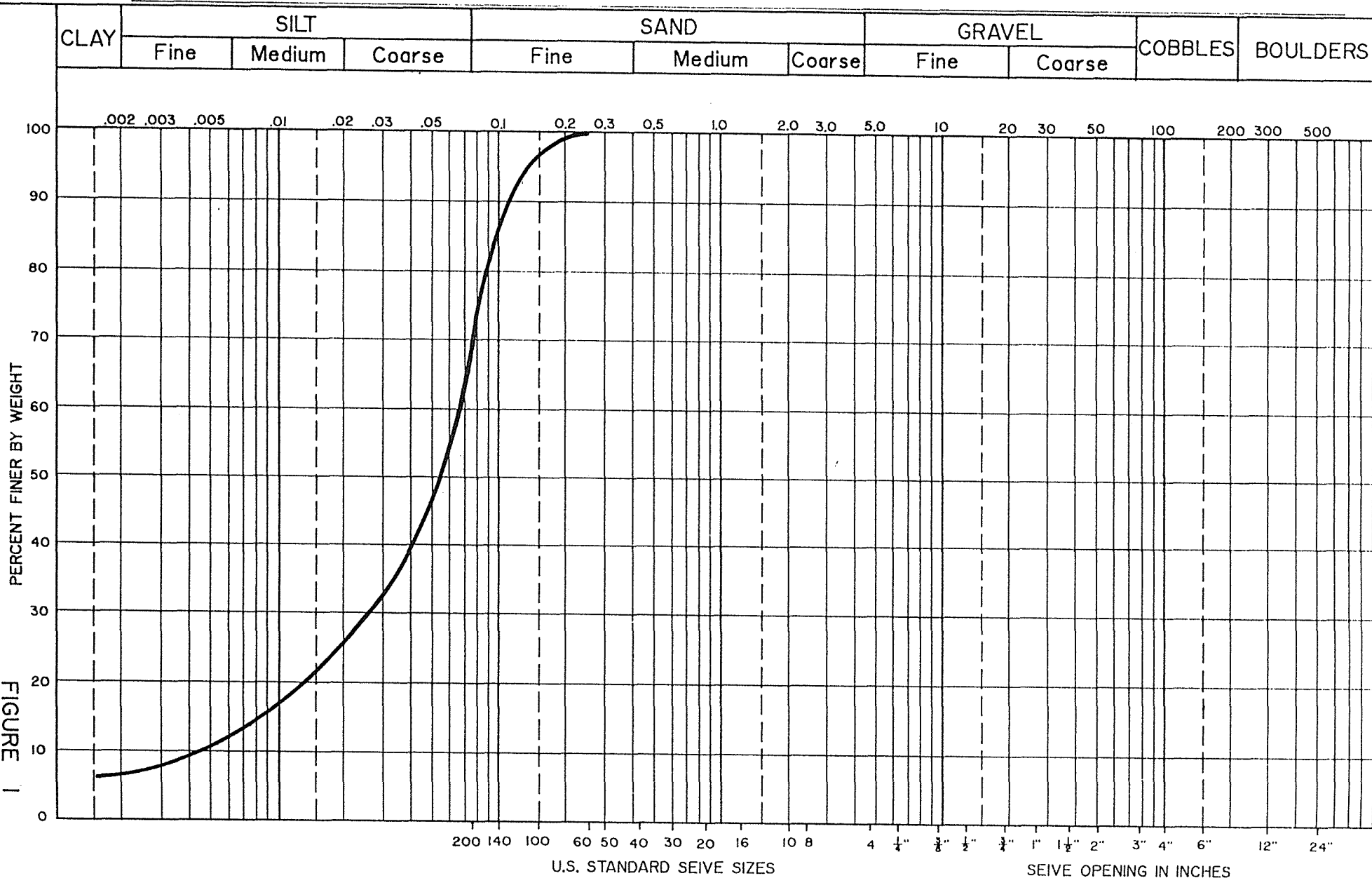

MT. POLLEY PROJECT

RELATIONSHIP BETWEEN COMPACTION ENERGY AND MOISTURE CONTENT - DENSITY

(CHARACTERISTIC COMPACTION CURVES FOR GLACIAL TILL)

Jan. 19, 1996
KNIGHT PIESOLD LTD.
CONSULTING ENGINEERS

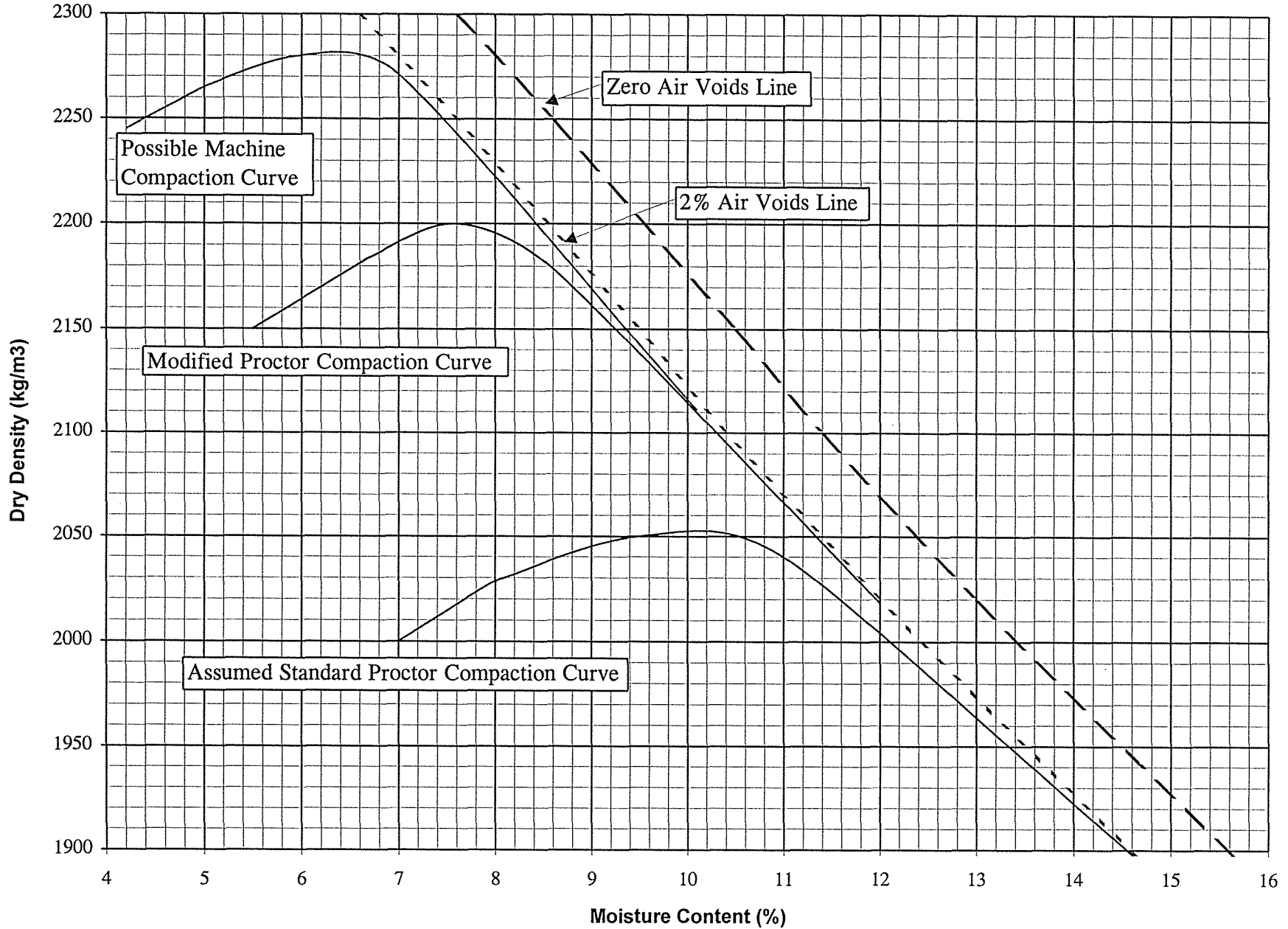

FIGURE 2

IMPERIAL METALS CORPORATION
MT. POLLEY PROJECT
STATIC STABILITY

Jan. 23, 1996
KNIGHT PIESOLD LTD.
CONSULTING ENGINEERS

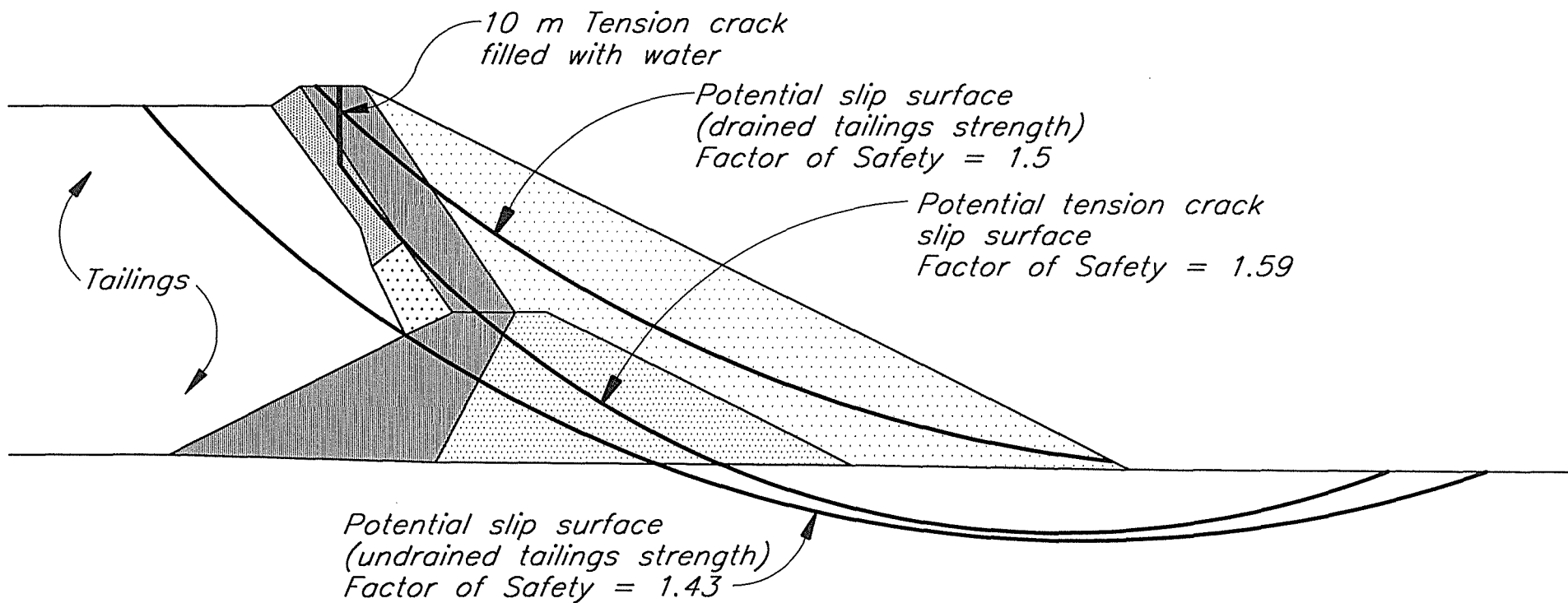
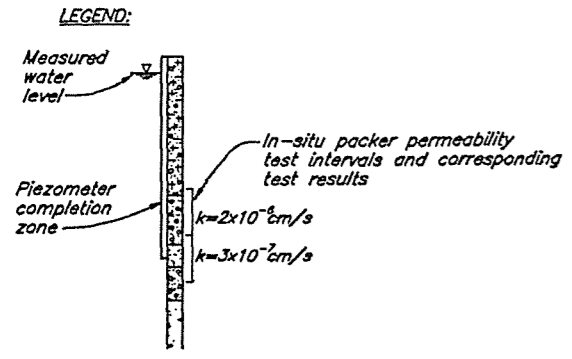
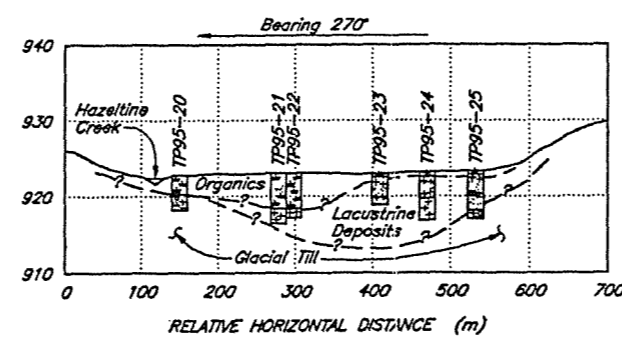
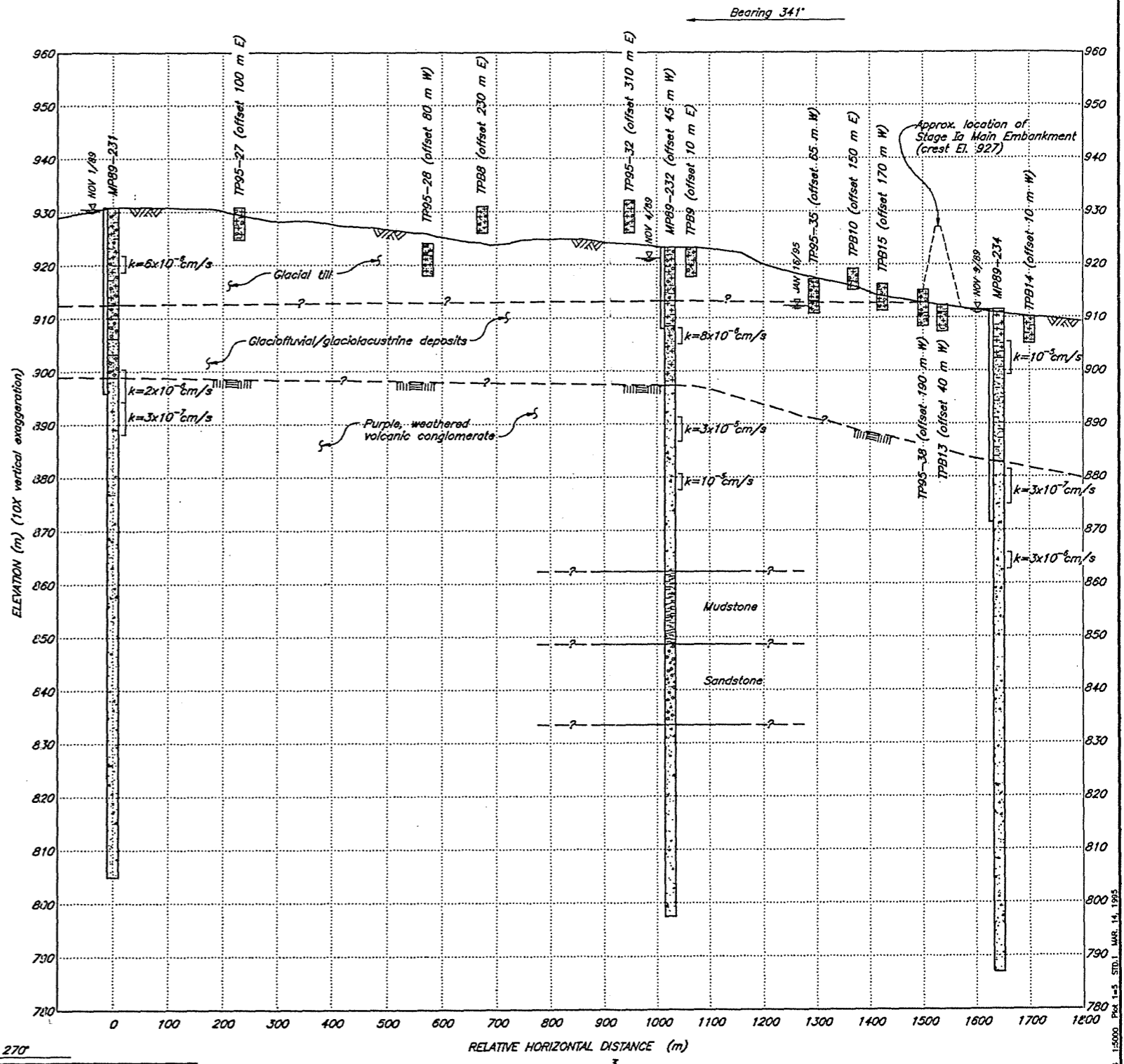
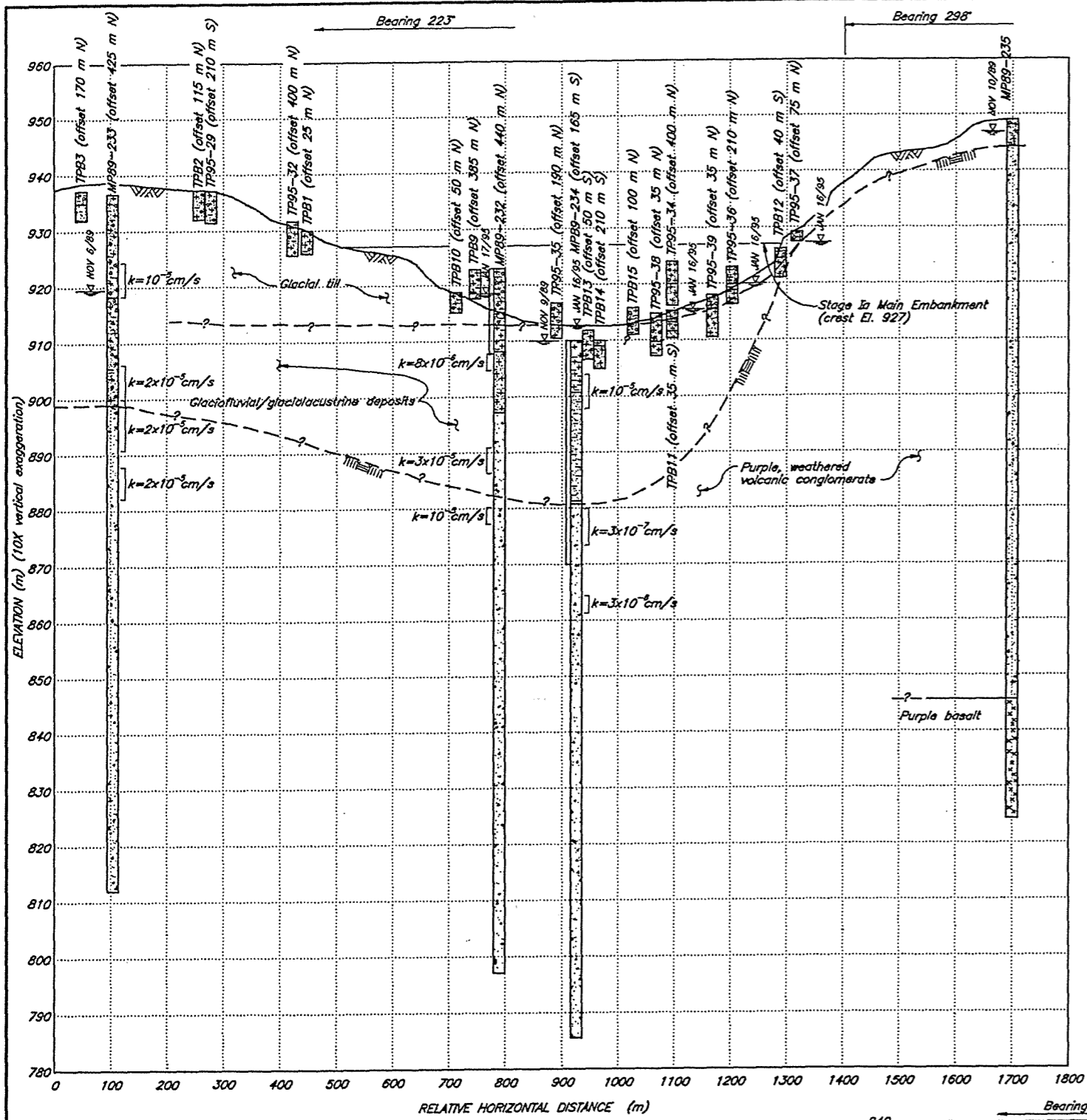

FIGURE 3



SECTION 2
1623.102
MAIN EMBANKMENT

SECTION 3
1623.102
TAILINGS BASIN

SECTION 1
1623.100
POLLEY LAKE DAM SITE

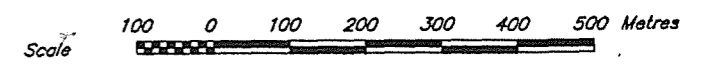

ORG. NO.	DESCRIPTION	REV.	DATE	DESCRIPTION	APPROVED	REV.	DATE	DESCRIPTION	APPROVED
	REFERENCE DRAWINGS			REVISIONS				REVISIONS	
						0	MAR. 14/95	ISSUED FOR REPORT	KJS

KNIGHT PIESOLD LIMITED
CONSULTING ENGINEERS - VANCOUVER, B.C.

K. J. BROUWER
ENGINEER

DESIGNED: KGB
DRAWN: NAR/RTD
CHECKED: KGB
APPROVED: KJS

DATE: MARCH 14, 1995

IMPERIAL METALS CORPORATION

MT. POLLEY PROJECT

TAILINGS STORAGE FACILITY
GEOLOGICAL CROSS-SECTIONS

SCALE AS SHOWN

DRG. NO. 1623.103

REV. 0

CAD FILE: PROJECT 1623.102.DWG 1:5000 PLOT 1-5 STD. 1 MAR. 14, 1995

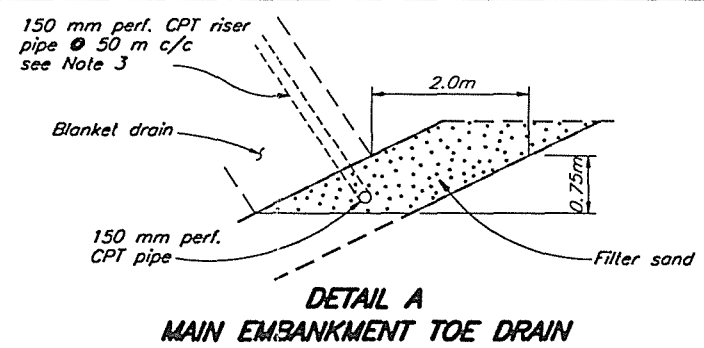
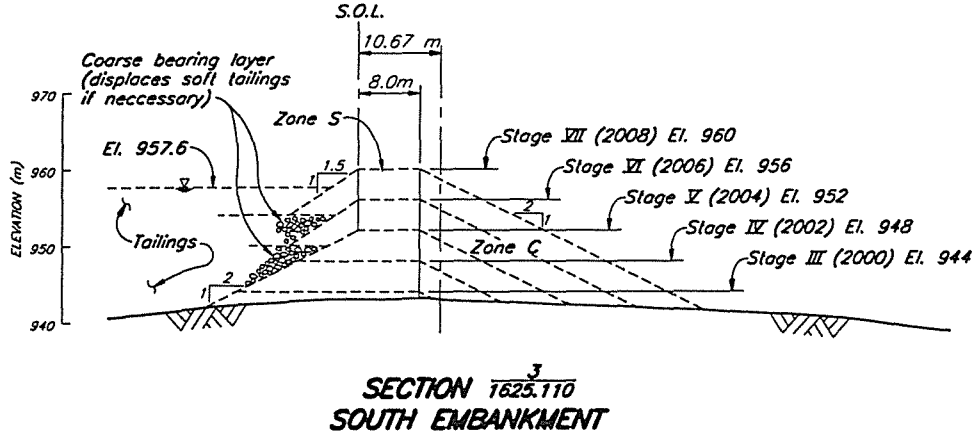
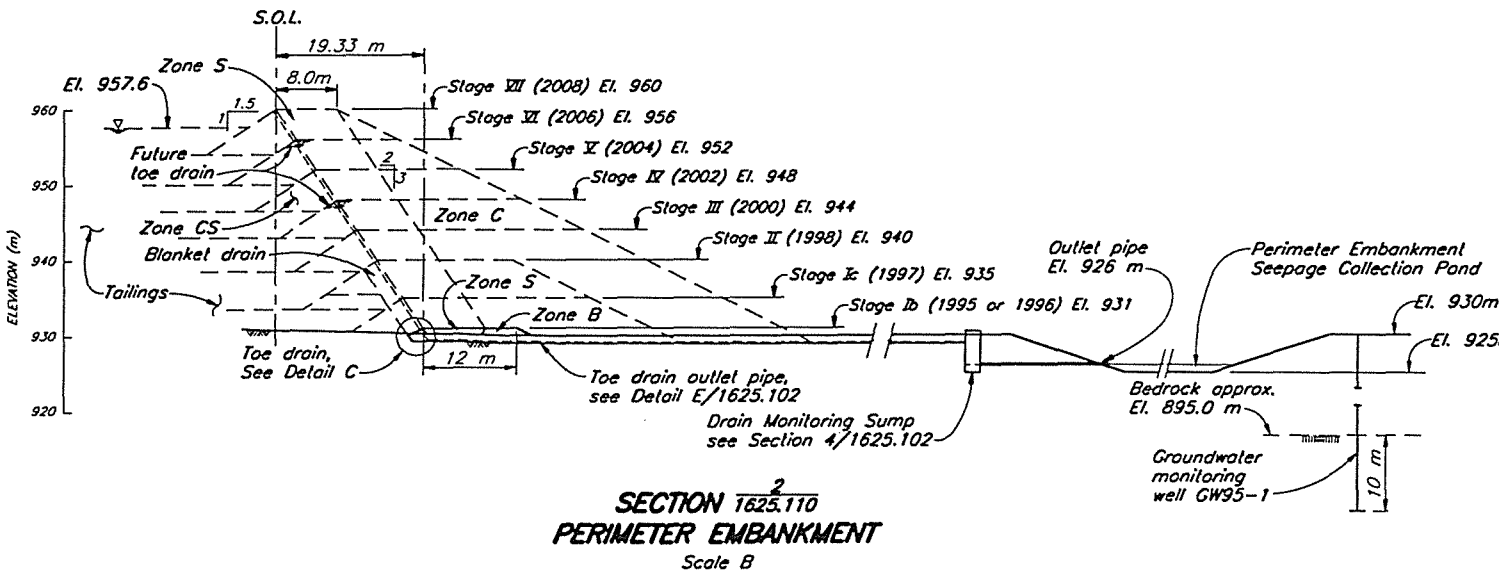
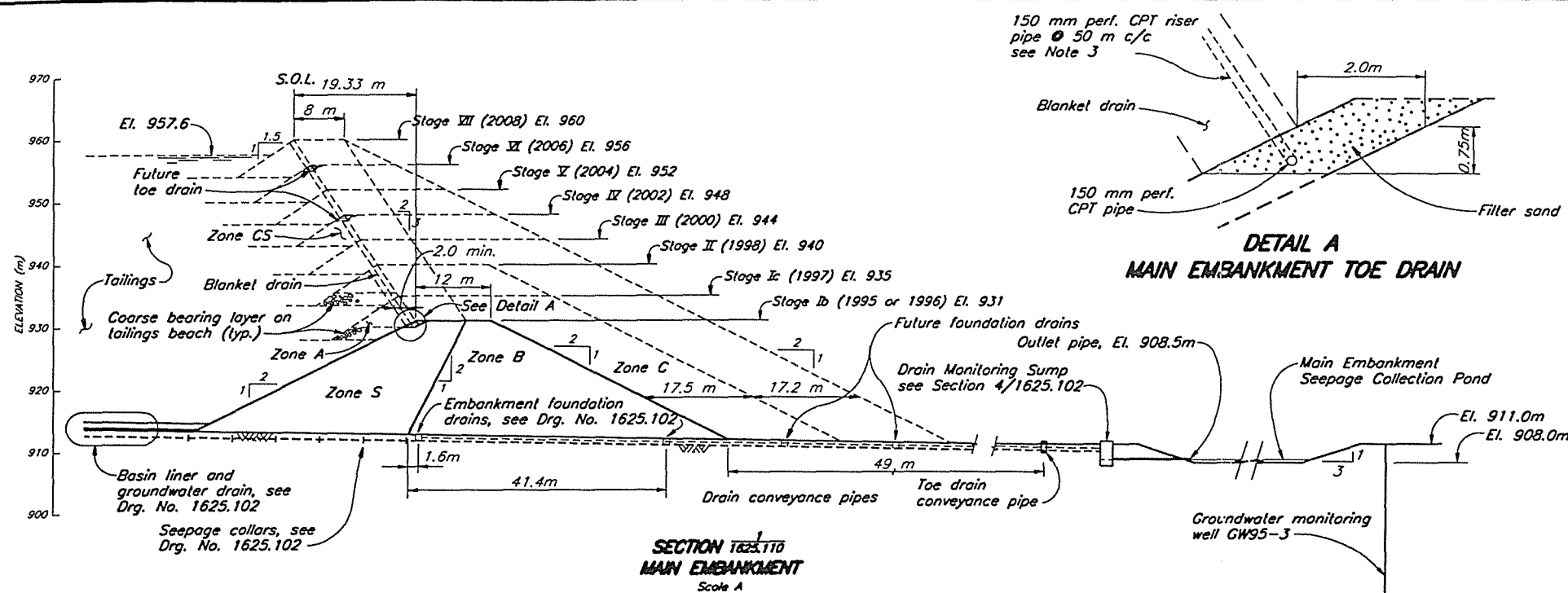

ZONE	MATERIAL TYPE	PLACEMENT AND COMPACTION REQUIREMENTS
Coarse Bearing Layer	Free draining durable waste rock fill or coarse sandy gravel	Placed and spread in maximum 1.0 m thick layers. Compaction as directed by the Engineer.
Chimney/Toe Drain	Filter sand	Placed and spread in maximum 1.0 m thick layers. Vibratory compaction as directed by the Engineer.
Drains	Drain Gravel	Placed and compacted as shown on the Drawings
S	Glacial till	Placed, moisture conditioned and spread in maximum 300 mm thick layers (after compaction). Vibratory compaction to 95% of modified proctor maximum dry density.
A	Glacial till	Placed, moisture conditioned and spread in maximum 600 mm thick layers (after compaction). Vibratory compaction to 90% of modified proctor maximum dry density.
B	Glacial till	Placed, moisture conditioned and spread in maximum 600 mm thick layers (after compaction). Vibratory compaction to 90% of modified proctor maximum dry density.
C	Random fill	Glacial till or other approved material placed in maximum 600 mm thick layers (after compaction). Vibratory compaction as required by the Engineer.
CS	Cycloned sand	Placed and spread in maximum 1.0 m thick layers. Vibratory compaction as directed by the Engineer.

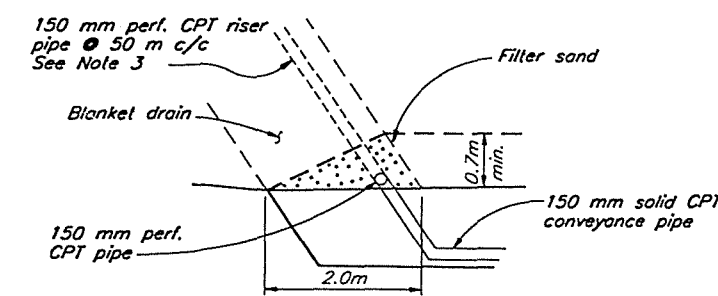
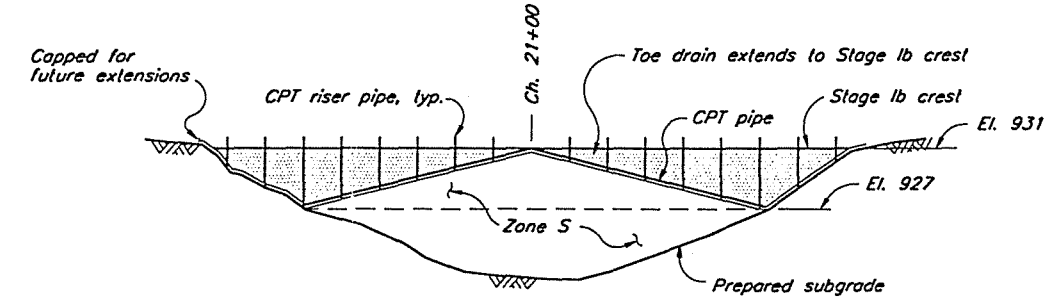
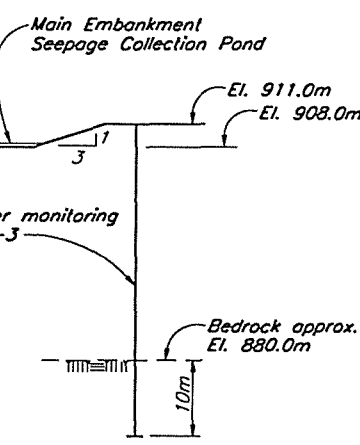

DETAIL B
UPSTREAM VIEW OF STAGE 1b
MAIN EMBANKMENT
N.T.S.

DETAIL C
PERIMETER EMBANKMENT TOE DRAIN

- NOTES
1. Groundwater monitoring wells to be installed by Others.
 2. Perimeter Embankment slopes 2H:1V as per Main Embankment.
 3. Perimeter Embankment seepage collection pond to be located in the field by the Engineer. Pipework invert elevations may be adjusted in the field by the Engineer.
 4. CPT Riser pipes to be installed for extensions during future embankment raises. Stages IV and VI will include a toe drain that is connected to existing outlet pipework. Additional outlet pipework to seepage ponds will be included if required.



1625.102	TAILINGS STORAGE FACILITY - FOUNDATION PREPARATION AND BASIN LINER - SECTIONS AND DETAILS
1625.110	TAILINGS STORAGE FACILITY - STAGE Ia/Ib TAILINGS IMPOUNDMENT - GENERAL ARRANGEMENT
DRG. NO.	DESCRIPTION
REFERENCE DRAWINGS	

REV.	DATE	DESCRIPTION	APPROVED
REVISIONS			

1	MAY 26/95	ISSUED FOR DESIGN REPORT	
0	APR. 6/95	ISSUED FOR REVIEW	
REV.	DATE	DESCRIPTION	APPROVED
REVISIONS			

KNIGHT PIESOLD LIMITED
CONSULTING ENGINEERS - VANCOUVER, B.C.

DESIGNED KDE
DRAWN JAL/WY
CHECKED MBS
APPROVED KJB

K. D. K. EMBREE
REGISTERED PROFESSIONAL ENGINEER

IMPERIAL METALS CORPORATION

MT. POLLEY PROJECT

TAILINGS STORAGE FACILITY
TAILINGS EMBANKMENT
SECTIONS AND DETAILS

DATE APRIL 6, 1995 SCALE AS SHOWN DRG. NO. 1625.111 REV. 1

CAD FILE: PROJECT\1625\01\01 1:500 PLOT 1-05 MAY 25, 1995

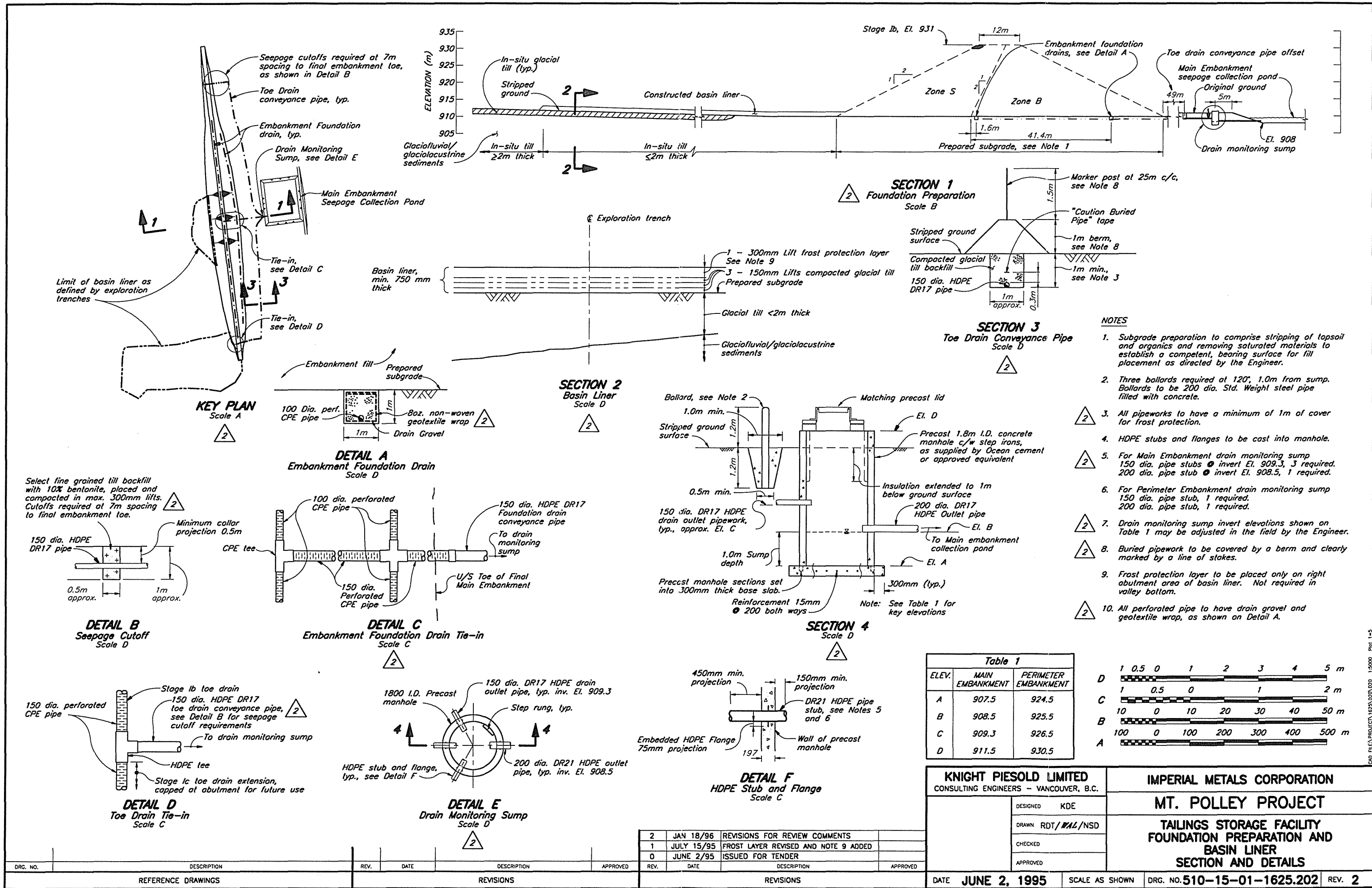

- NOTES**
1. Subgrade preparation to comprise stripping of topsoil and organics and removing saturated materials to establish a competent, bearing surface for fill placement as directed by the Engineer.
 2. Three bollards required at 120', 1.0m from sump. Bollards to be 200 dia. Std. Weight steel pipe filled with concrete.
 3. All pipeworks to have a minimum of 1m of cover for frost protection.
 4. HDPE stubs and flanges to be cast into manhole.
 5. For Main Embankment drain monitoring sump 150 dia. pipe stubs @ invert El. 909.3, 3 required. 200 dia. pipe stub @ invert El. 908.5, 1 required.
 6. For Perimeter Embankment drain monitoring sump 150 dia. pipe stub, 1 required. 200 dia. pipe stub, 1 required.
 7. Drain monitoring sump invert elevations shown on Table 1 may be adjusted in the field by the Engineer.
 8. Buried pipework to be covered by a berm and clearly marked by a line of stakes.
 9. Frost protection layer to be placed only on right abutment area of basin liner. Not required in valley bottom.
 10. All perforated pipe to have drain gravel and geotextile wrap, as shown on Detail A.

Table 1

ELEV.	MAIN EMBANKMENT	PERIMETER EMBANKMENT
A	907.5	924.5
B	908.5	925.5
C	909.3	926.5
D	911.5	930.5

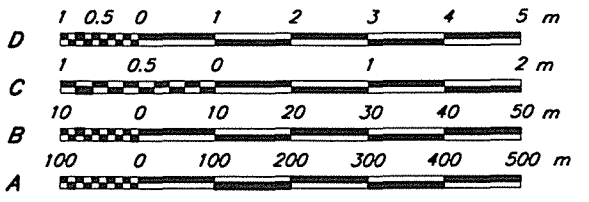

KNIGHT PIESOLD LIMITED CONSULTING ENGINEERS - VANCOUVER, B.C.		IMPERIAL METALS CORPORATION	
DESIGNED	KDE	MT. POLLEY PROJECT	
DRAWN	RDT/MAL/NSD	TAILINGS STORAGE FACILITY	
CHECKED		FOUNDATION PREPARATION AND	
APPROVED		BASIN LINER	
		SECTION AND DETAILS	
DATE	JUNE 2, 1995	SCALE AS SHOWN	DRG. NO. 510-15-01-1625.202
			REV. 2

REV.	DATE	DESCRIPTION	APPROVED
2	JAN 18/96	REVISIONS FOR REVIEW COMMENTS	
1	JULY 15/95	FROST LAYER REVISED AND NOTE 9 ADDED	
0	JUNE 2/95	ISSUED FOR TENDER	

DRG. NO.	DESCRIPTION	REV.	DATE	DESCRIPTION	APPROVED
	REFERENCE DRAWINGS			REVISIONS	



SETTING OUT POINTS			
Description	Point	Northing	Easting
Setting Out Line (S.O.L.)	S1	5 818 622.590	594 258.688
	S2	5 818 392.402	594 765.778
	S3	5 818 365.375	594 995.246
	S4	5 818 238.539	595 240.350
	S5	5 818 966.983	596 208.866
	S6	5 819 304.035	595 955.881
	S7	5 819 932.340	595 066.670
	S8	5 820 025.632	594 375.061
Stage Ib Main Embankment E	S9	5 818 891.014	596 150.000
	S10	5 818 199.059	595 230.000
Perimeter Embankment E	S11	5 819 705.338	595 404.339
	S12	5 819 869.082	595 160.766
Stripping Limits	S13	5 818 233.372	595 392.851
	S14	5 818 696.416	595 997.943
	S15	5 818 828.350	596 066.684
Main Embankment Seepage Collection Pond	S19	5 818 461.203	595 790.290
	S20	5 818 391.047	595 697.013
	S21	5 818 317.351	595 752.085
	S22	5 818 387.678	595 845.590
Reclaim Barge Channel	S23	5 818 743.870	595 479.103
	C5	5 818 856.841	595 365.834
	BC	5 818 879.675	595 408.055
	EC	5 818 903.862	595 375.481
	PI5	5 818 899.065	595 397.857
	S24	5 818 998.167	594 887.106
Bootjack - Moorehead Connector Relocation	C1	5 818 523.688	595 775.212
	BC	5 818 405.938	595 887.923
	EC	5 818 393.421	595 873.189
	PI1	5 818 399.242	595 880.928
Bootjack - Moorehead Connector Relocation	C2	5 818 222.184	595 400.960
	BC	5 818 104.704	595 489.320
	EC	5 818 093.995	595 472.909
	PI2	5 818 098.801	595 481.472
Bootjack - Moorehead Connector Relocation	C3	5 818 096.998	595 273.949
	BC	5 818 009.797	595 322.894
	EC	5 818 002.473	595 241.322
	PI3	5 817 987.827	595 283.752
Bootjack - Moorehead Connector Relocation	C4	5 818 228.844	594 248.367
	BC	5 818 333.078	594 283.514
	EC	5 818 307.478	594 171.448
	PI4	5 818 354.995	594 220.025

- LEGEND:**
- GW95-1 - Groundwater monitoring well
 - C1 - Curve No. 1 (typ.)
 - BC - Begin Curve
 - EC - End Curve
 - PI1 - Point of Intersection for Curve No. 1

- NOTES**
1. Setting Out Line (SOL) is the upstream shoulder of the Stage VII embankment.
 2. Stripping and clearing required 5m beyond seepage collection ponds and pipeworks.
 3. Perimeter Embankment Seepage Collection Pond to be located in the field by the Engineer.
 4. Number and location of cross-drain culverts to be determined in the field by the Engineer.

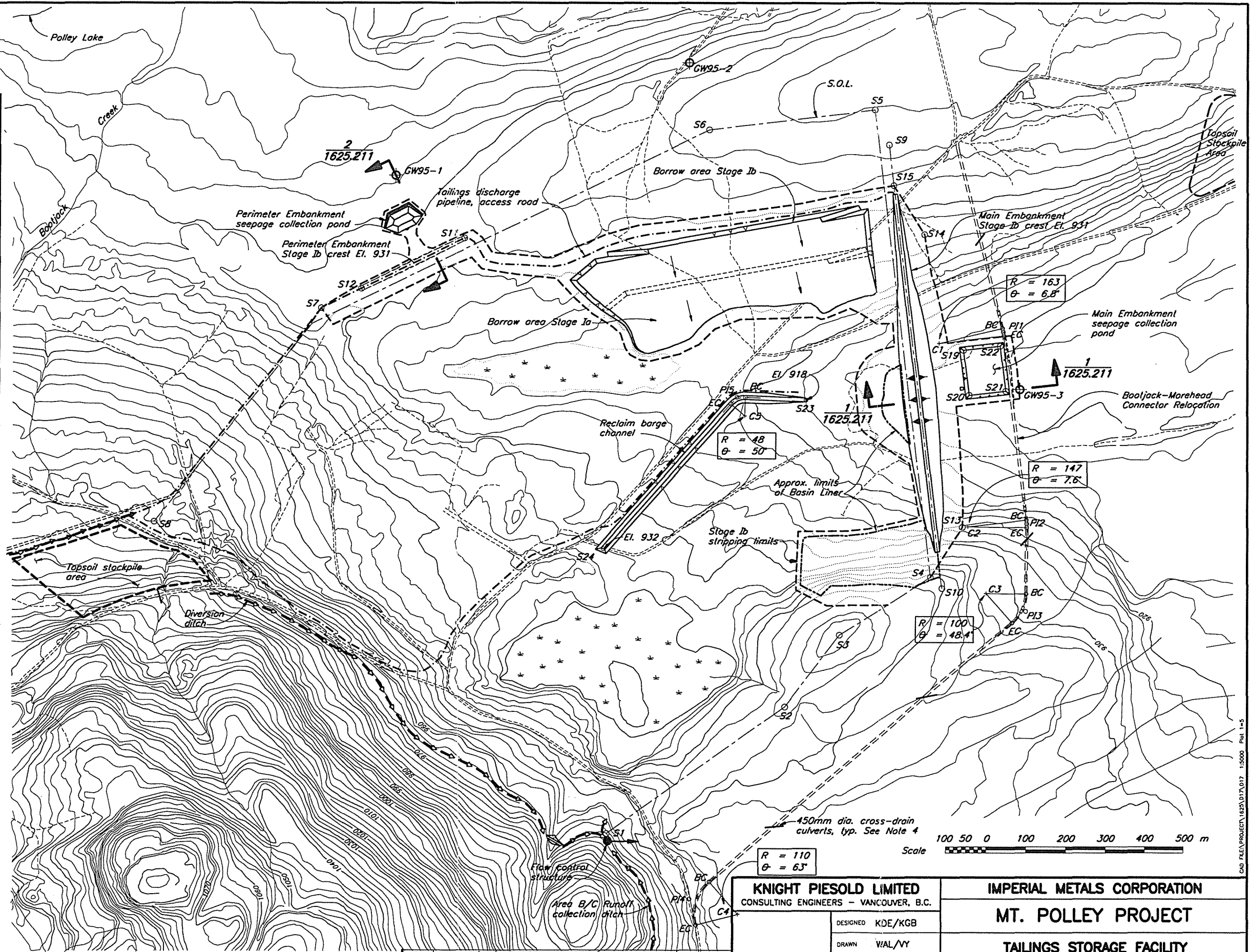

1625.211	TAILINGS STORAGE FACILITY - TAILINGS EMBANKMENT - SECTIONS AND DETAILS
DRG. NO.	DESCRIPTION
REFERENCE DRAWINGS	

REV.	DATE	DESCRIPTION	APPROVED
2	JAN. 18/96	REVISED SEEPAGE COLLECTION POND	
1	JULY 27/95	POINT S16 AND S17 DELETED	
0	JUNE 2/95	ISSUED FOR TENDER	

REV.	DATE	DESCRIPTION	APPROVED
2	JAN. 18/96	REVISED SEEPAGE COLLECTION POND	
1	JULY 27/95	POINT S16 AND S17 DELETED	
0	JUNE 2/95	ISSUED FOR TENDER	

KNIGHT PIESOLD LIMITED CONSULTING ENGINEERS - VANCOUVER, B.C.	
DESIGNED	KDE/KGB
DRAWN	VIAL/VY
CHECKED	
APPROVED	

IMPERIAL METALS CORPORATION	
MT. POLLEY PROJECT	
TAILINGS STORAGE FACILITY	
STAGE Ib TAILINGS IMPOUNDMENT	
GENERAL ARRANGEMENT	

DATE	JUNE 2, 1995	SCALE AS SHOWN	DRG. NO. 510-12-02-1625.205	REV. 2
------	--------------	----------------	-----------------------------	--------

CAD FILE: PROJECT\625\517\017 1:5000 Plot 1-5

UNIFIED SOIL CLASSIFICATION SYSTEM

PROJECT: ZONE - S AND B
MATERIAL - GLACIAL TILL

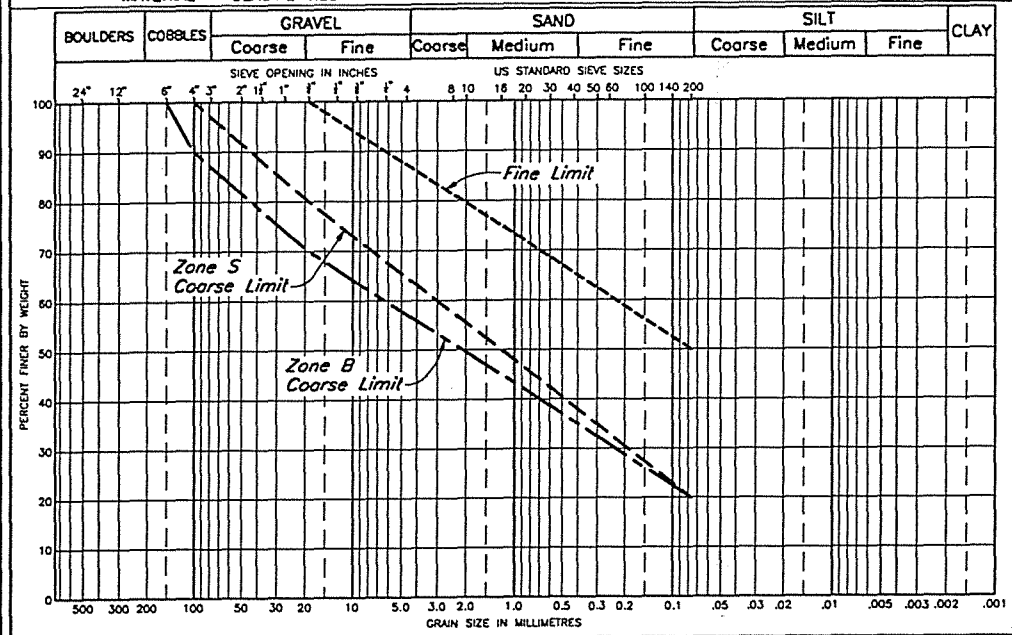

UNIFIED SOIL CLASSIFICATION SYSTEM

PROJECT: ZONE - TOE DRAIN
MATERIAL - FILTER SAND

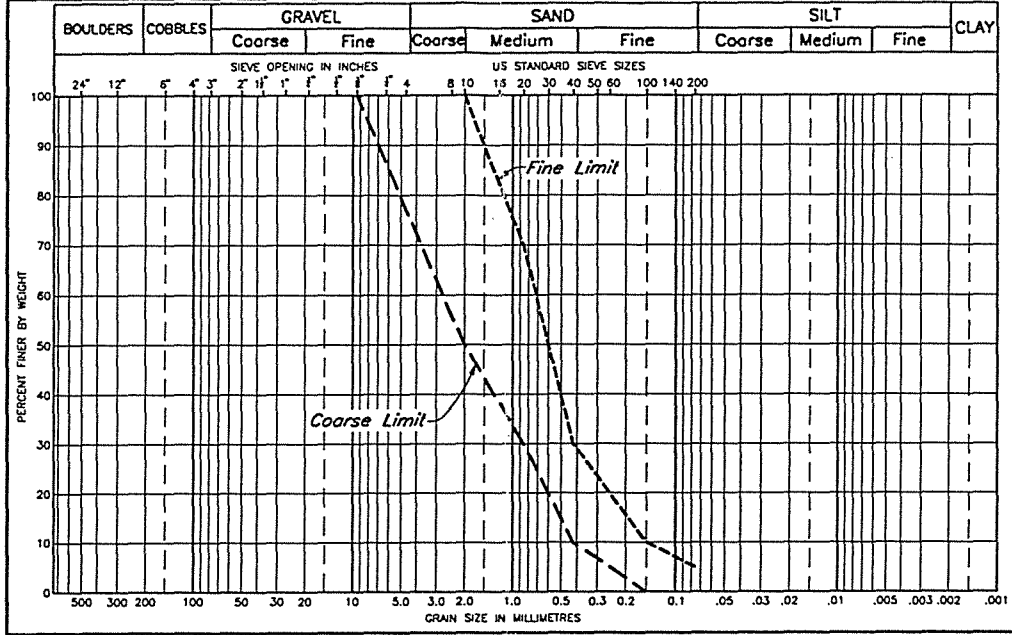

UNIFIED SOIL CLASSIFICATION SYSTEM

PROJECT: ZONE - PIPE SURROUND
MATERIAL - DRAIN GRAVEL

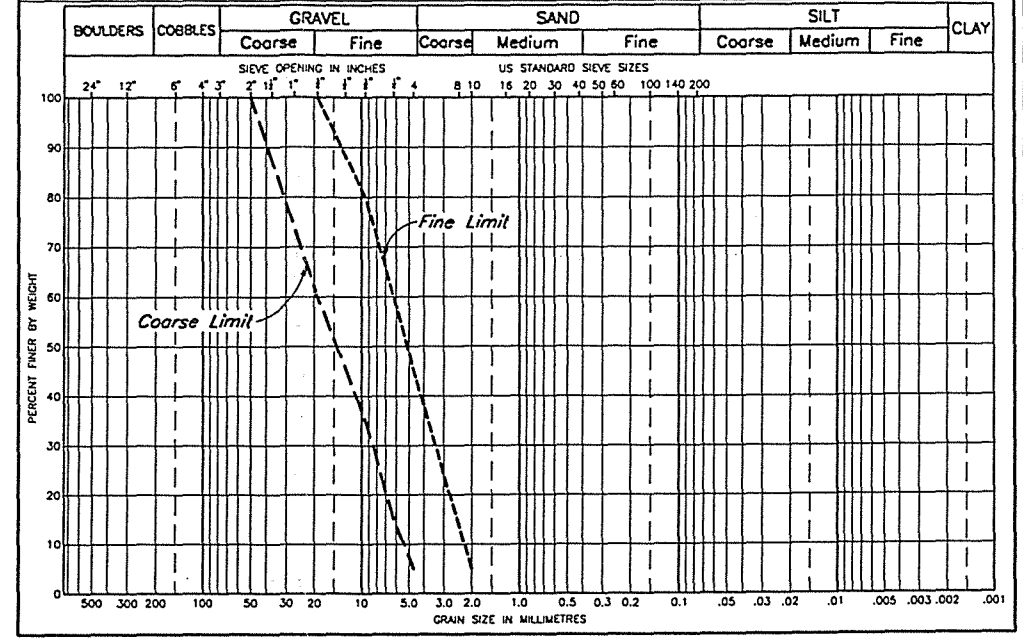

UNIFIED SOIL CLASSIFICATION SYSTEM

PROJECT: ZONE - BASIN LINER
MATERIAL - GLACIAL TILL

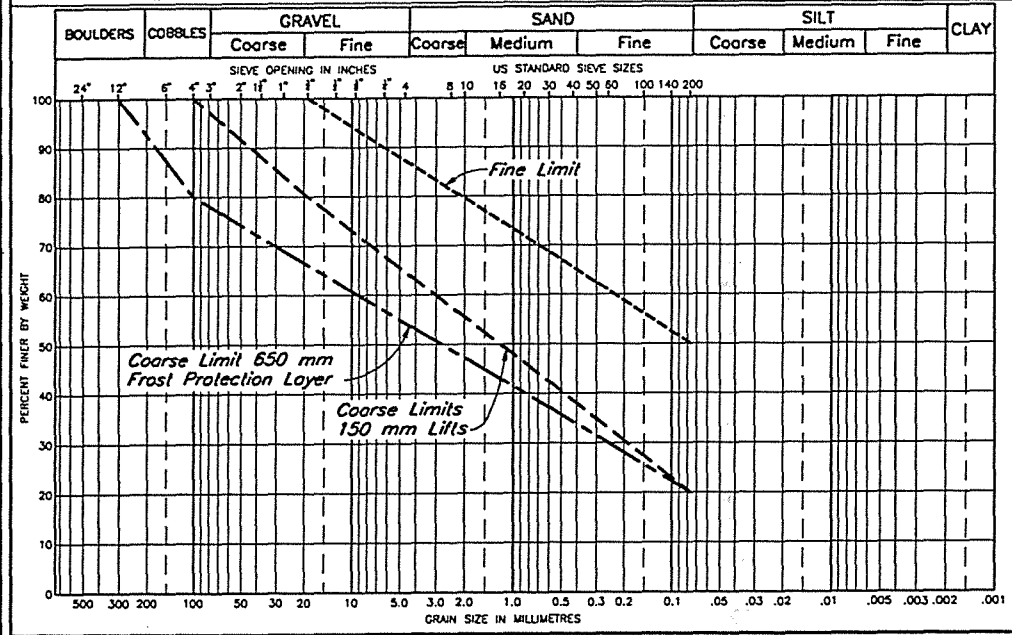

UNIFIED SOIL CLASSIFICATION SYSTEM

PROJECT: ZONE - DITCH EROSION PROTECTION
MATERIAL - RIPRAP

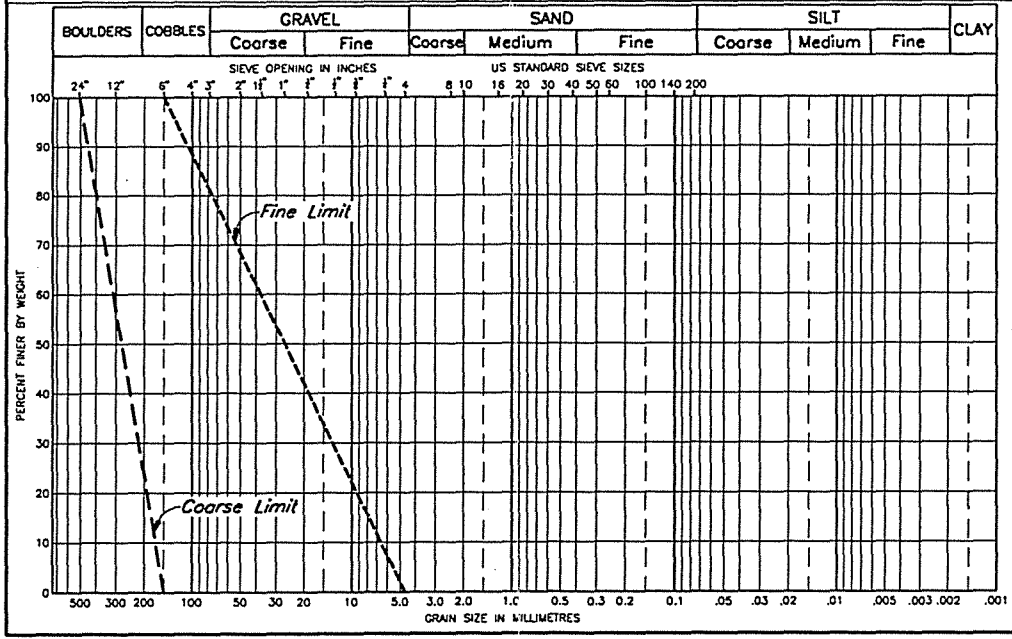

UNIFIED SOIL CLASSIFICATION SYSTEM

PROJECT: ZONE - ROAD SURFACING
MATERIAL - WEARING COURSE

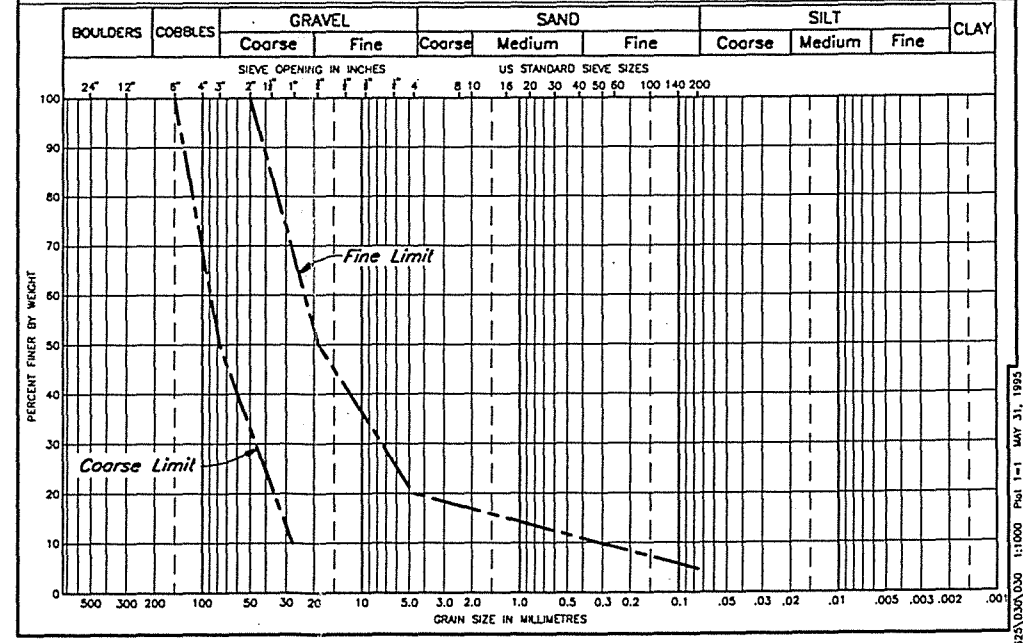

NOTES

- No more than 10% of Zone S material shall be coarser than the Zone S Coarse Limit and such material shall be finer than the Zone B coarse limit. Zone S material which has a gradation between the Zone S and B coarse limits shall be well spaced out and shall not form continuous layers or sizeable lenses.
- For Filter sand, the portion passing the No. 40 sieve must have a plasticity index (PI) of zero.

DRG. NO.	DESCRIPTION	REV.	DATE	DESCRIPTION	APPROVED	REV.	DATE	DESCRIPTION	APPROVED
	REFERENCE DRAWINGS			REVISIONS		0	JUNE 2/95	ISSUED FOR TENDER	

KNIGHT PIESOLD LIMITED CONSULTING ENGINEERS - VANCOUVER, B.C.		IMPERIAL METALS CORPORATION	
DESIGNED	KDE	MT. POLLEY PROJECT	
DRAWN	ROT	TAILINGS STORAGE FACILITY	
CHECKED		MATERIAL SPECIFICATIONS	
APPROVED		DATE	JUNE 2, 1995
		SCALE AS SHOWN	DRG. NO. 510-14-03-1625.212
		REV.	0

C:\D:\PROJECTS\1625\212\030 1:1000 PLOT 1-1 MAY 31, 1995

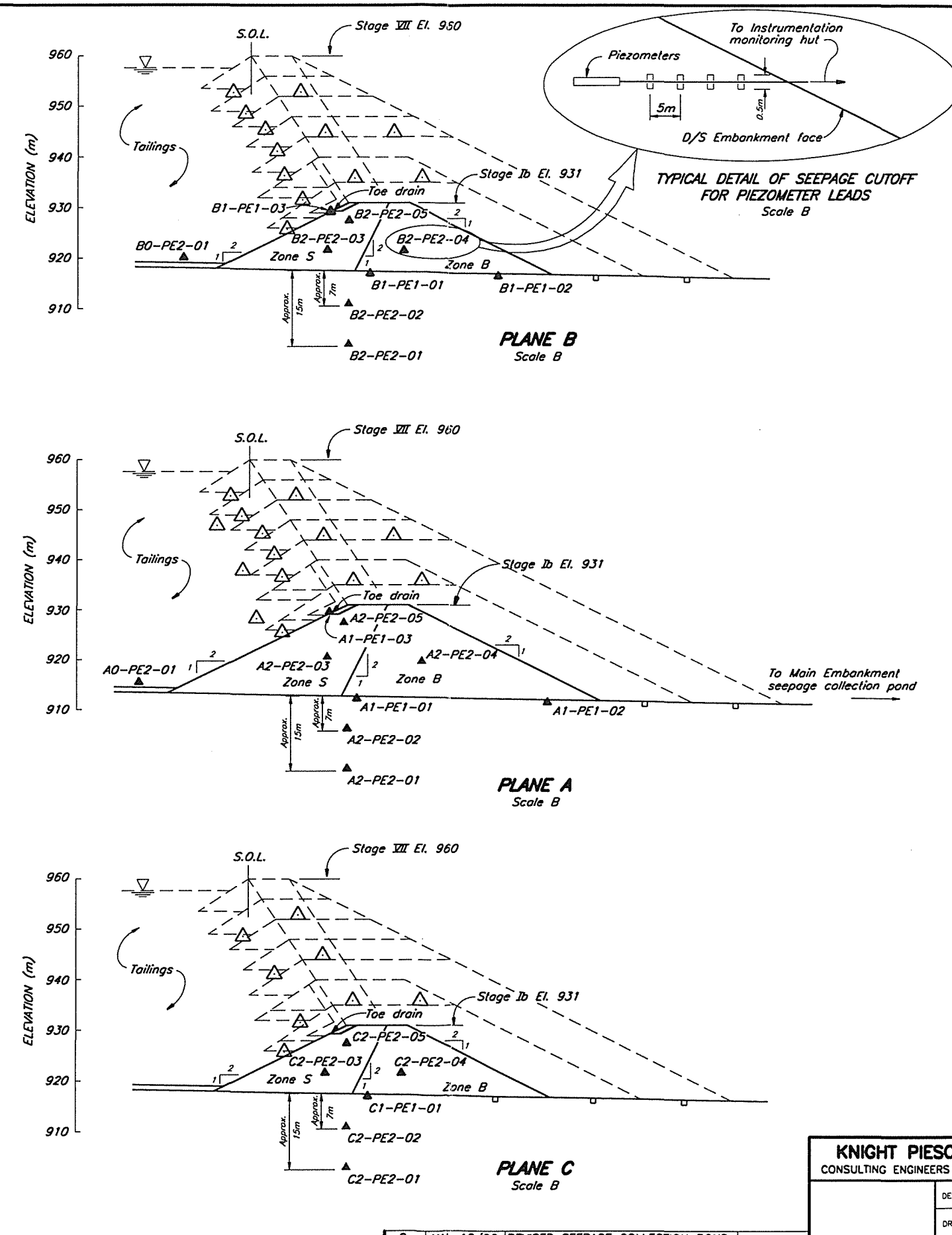
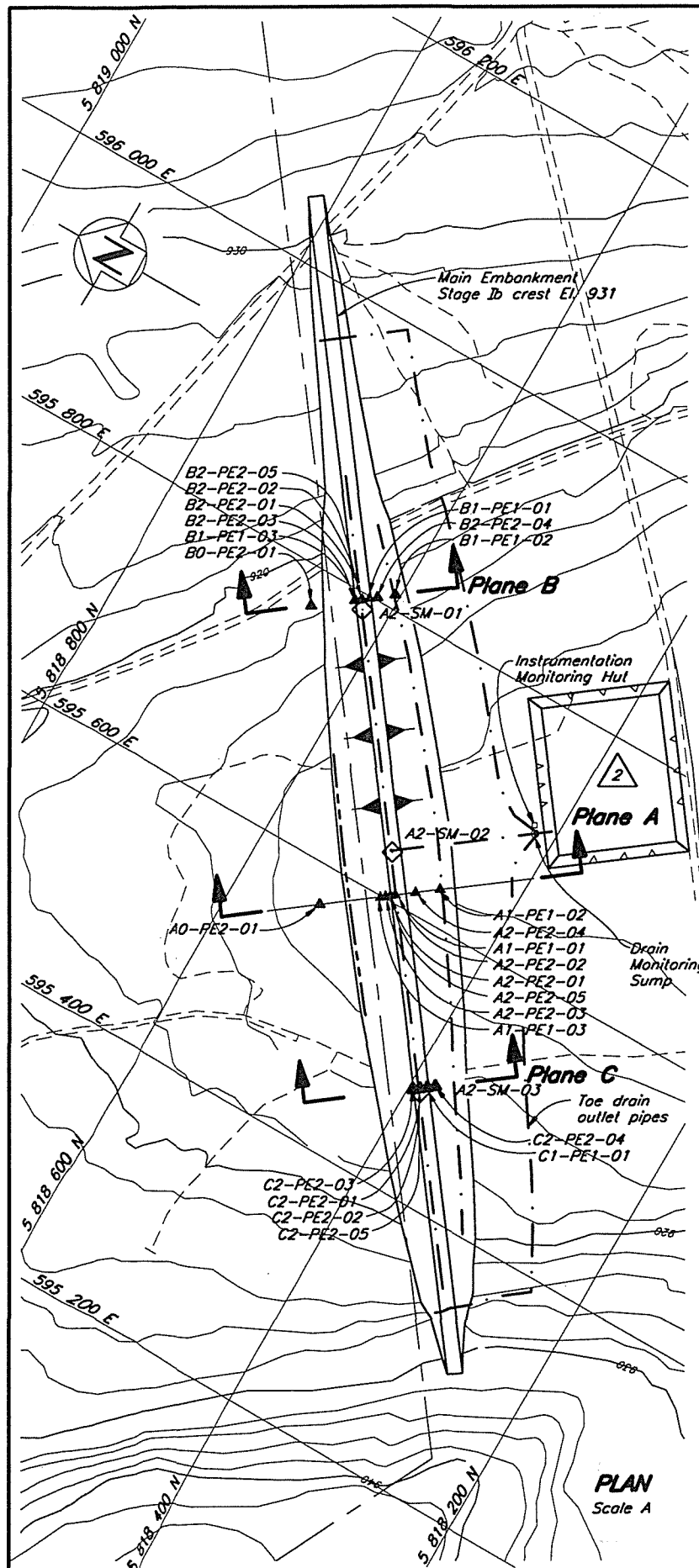

- NOTES**
1. Piezometers are vibrating type, RST or equivalent, connected to a readout panel via heavy duty direct burial cable.
 2. Piezometer leads are to be extended to a prefabricated monitoring hut located downstream of the final embankment toe.
 3. A schedule required for piezometer types and lead lengths will be provided in the Technical Specifications.
 4. Future survey monuments not shown. A minimum of 2 monuments will be installed for each embankment raise.

- LEGEND**
- Plane I.D. (A, B etc.)
 - Area (0-Tailings, 1-Drain, 2-Embankment)
 - AO-PE1-01—Number I.D.
 - Pressure Rating (1-Low, 2-High)
 - Type of Instrumentation (PE—Piezometer electric, SM—Survey Monument)
 - A0-PE2-01 ▲ Tailings mass piezometer
 - A1-PE1-01 ▲ Embankment foundation drain and toe drain piezometer
 - A2-PE2-01 ▲ Embankment foundation and fill piezometer
 - A2-SM-01 ◆ Embankment survey monument
 - △ Future Piezometers

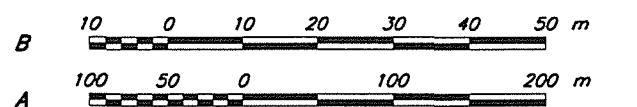

1625.221	TAILINGS STORAGE FACILITY - INSTRUMENTATION - SECTIONS AND DETAILS
ORG. NO.	DESCRIPTION
REFERENCE DRAWINGS	

REV.	DATE	DESCRIPTION	APPROVED

REV.	DATE	DESCRIPTION	APPROVED
2	JAN. 18/96	REVISED SEEPAGE COLLECTION POND	
1	JULY 27/95	BASIN GROUNDWATER DRAINS REVISED	
0	JUNE 2/95	ISSUED FOR TENDER	

KNIGHT PIESOLD LIMITED CONSULTING ENGINEERS - VANCOUVER, B.C.	
DESIGNED	GRG
DRAWN	RDT/WY
CHECKED	
APPROVED	
DATE	JUNE 2, 1995

IMPERIAL METALS CORPORATION	
MT. POLLEY PROJECT	
TAILINGS STORAGE FACILITY INSTRUMENTATION	
SCALE AS SHOWN	DRG. NO. 510-77-01-1625.220
REV. 2	

CAD FILE PROJECT: 1625.023.023_1:2500_P01.1-2.2

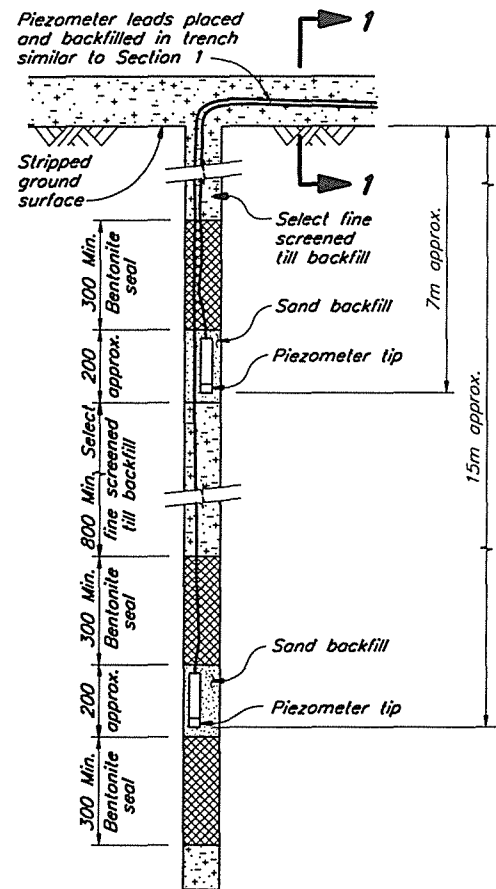

**DETAIL A
INSTALLATION OF PIEZOMETERS
IN BOREHOLES**
N.T.S.

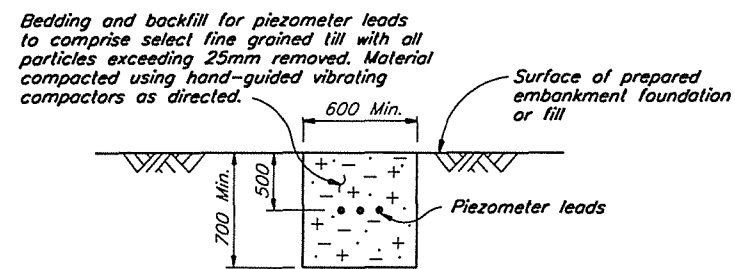

**SECTION 1
TYPICAL SECTION THROUGH PIEZOMETER LEAD
TRENCH IN PREPARED EMBANKMENT FOUNDATION
OR IN ZONE S AND B FILL**
N.T.S.

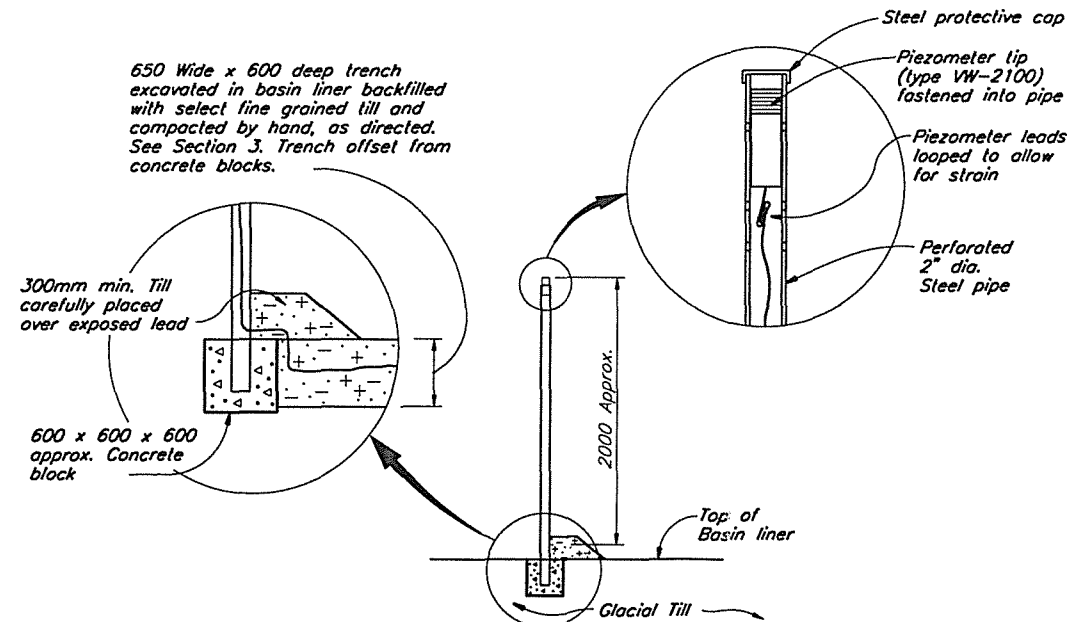

**DETAIL B
VERTICAL SUPPORT FOR TAILINGS PIEZOMETERS**
N.T.S.

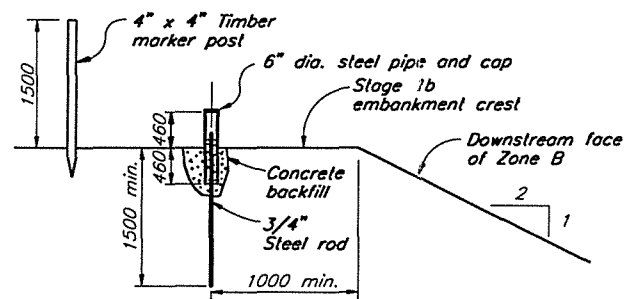

**DETAIL OF
SURFACE MOVEMENT MONUMENT**
N.T.S.

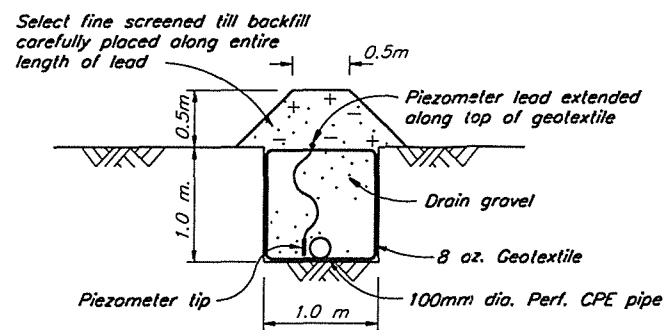

**DETAIL C
TYPICAL PIEZOMETER INSTALLATION IN
EMBANKMENT FOUNDATION DRAIN OR TOE DRAIN**
N.T.S.

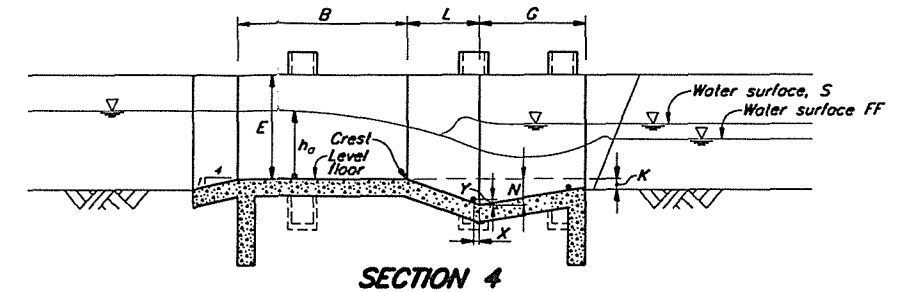
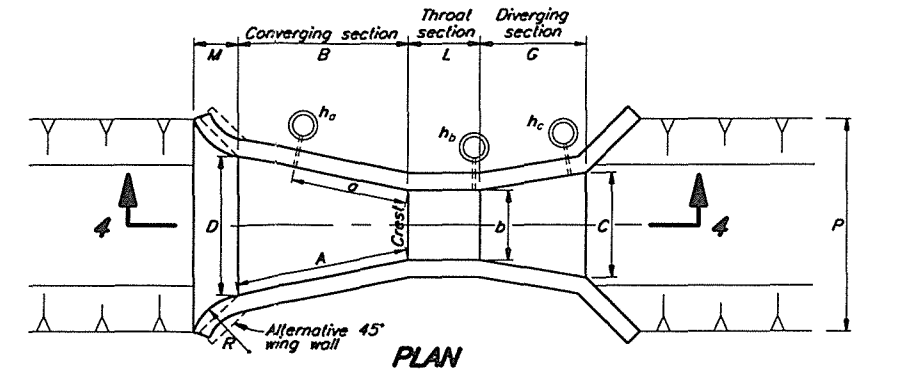

**PARSHALL FLUME (2 FT. SIZE), DETAIL B/1625.215
FLOW MEASUREMENT FOR INFLOWS TO TAILINGS STORAGE FACILITY
AREA B RUNOFF COLLECTION AND TAILINGS AREA DIVERSION DITCHES**

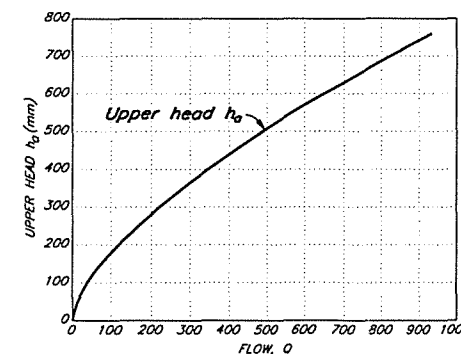

Dimensions for Parshall flume with throat width b _c of 2 feet.	
b _c	609.6
A	1524
a	1016
B	1495
C	914
D	1206
E	914
L	610
G	914
H	-
K	76
M	381
N	229
P	1854
R	508
X	51
Y	76
Z	-



DRG. NO.	DESCRIPTION	REV.	DATE	DESCRIPTION	APPROVED
1625.220	TAILINGS STORAGE FACILITY - INSTRUMENTATION				
	REFERENCE DRAWINGS			REVISIONS	

REV.	DATE	DESCRIPTION	APPROVED
1	JAN. 18/96	GROUNDWATER DRAINS REMOVED	
0	JUNE 2/95	ISSUED FOR TENDER	

KNIGHT PIESOLD LIMITED CONSULTING ENGINEERS - VANCOUVER, B.C.		IMPERIAL METALS CORPORATION	
DESIGNED	KDE/MBS	MT. POLLEY PROJECT	
DRAWN	VY	TAILINGS STORAGE FACILITY INSTRUMENTATION SECTIONS AND DETAILS	
CHECKED			
APPROVED			
DATE JUNE 2, 1995		SCALE AS SHOWN	DRG. NO. 510-77-02-1625.221 REV. 1

APPENDIX A

**TEST PIT LOGS FROM 1995
SUPPLEMENTARY INVESTIGATIONS**



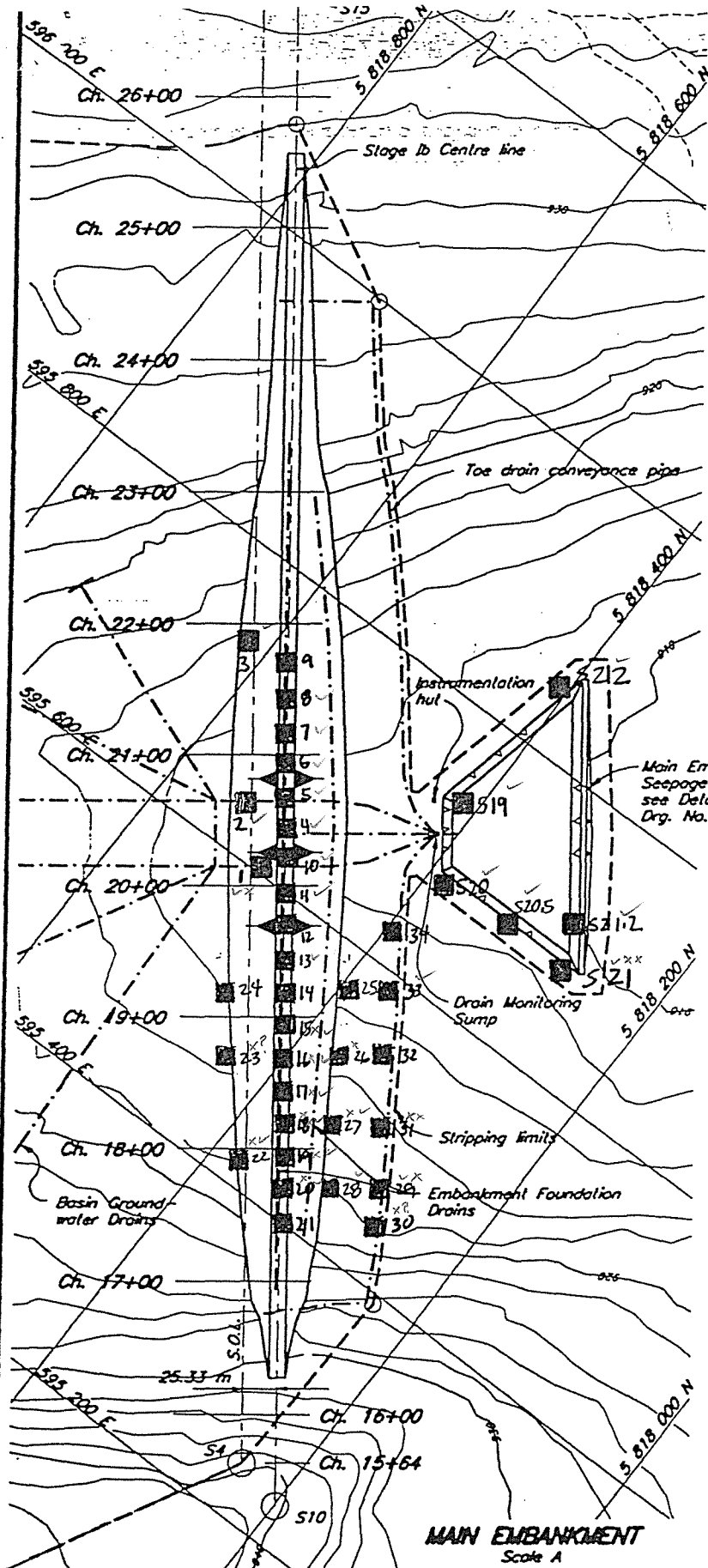
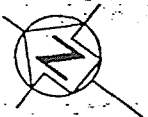

✓ < 3m to silt/sand
 x Sand, perm

- 24 - Main Embankment Test Pits (TP95ME-24)
- S21 - Seepage Collection Pond Test Pits (TPS21)

NO
 1.
 2.
 3.
 4.

50
 E
 10x
 A
 E

MAIN EMBANKMENT
 Scale A

1625.202	TAILINGS STORAGE FACILITY - FOUNDATION PREPARATION AND BASIN LINER - SECTIONS AND DETAILS
1625.214	TAILINGS STORAGE FACILITY - SEDIMENT CONTROL AND SEEPAGE COLLECTION - SECTIONS AND DETAILS
DRG. NO.	DESCRIPTION
REFERENCE DRAWINGS	

REV.	DATE	DESCRIPTION	APPROVED	A	M
REVISIONS					

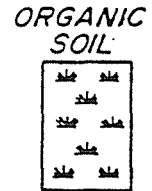
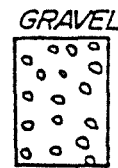
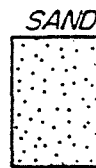
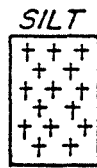
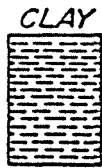

The symbols may be combined to denote various soil combinations, the predominant soil being heavier.

RELATIVE PROPORTIONS

<u>TERM</u>	<u>RANGE</u>
Trace	0 - 10%
Some	10 - 20%
"y" or "ey"	20 - 35%
and	35 - 50%

ie. CLAY - silty, trace sand
means : Clay soil with 20% to 35% silt
and 0% to 10% sand

CLASSIFICATION BY PARTICLE SIZE

Boulder	Over 8"
Cobble	3" - 8"
Gravel -	
Coarse	3/4" - 3"
Fine	# 4 - 3/4"
Sand -	
Coarse	# 4 - #10
Medium	#10 - #40
Fine	#40 - #200
Silt	#200 - #0.002 mm
Clay	Finer than 0.002 mm

NOTE

Sieve sizes shown are U.S. standard

DENSITY OF SANDS AND GRAVELS

<u>DESCRIPTIVE TERM</u>	<u>RELATIVE DENSITY</u>	<u>STANDARD PENETRATION TEST</u>
Very loose	0 - 15%	0 - 4 Blows per foot
Loose	15 - 35%	4 - 10 Blows per foot
Medium dense	35 - 65%	10 - 30 Blows per foot
Dense	65 - 85%	30 - 50 Blows per foot
Very dense	85 - 100%	Over 50 Blows per foot

CONSISTENCY OF CLAYS AND SILTS

<u>DESCRIPTIVE TERM</u>	<u>UNCONFINED COMPRESSIVE STRENGTH</u>		<u>N VALUE STANDARD PENETRATION TEST</u>	<u>REMARKS</u>
	<u>kPa</u>	<u>TSF</u>		
Very soft	< 25	< 0.25	Less than 2	- Can penetrate with fist
Soft	25 - 50	0.25 - 0.5	2 - 4	- Can indent with fist
Firm	50 - 100	0.5 - 1.0	4 - 8	- Can penetrate with thumb
Stiff	100 - 200	1.0 - 2.0	8 - 15	- Can indent with thumb
Very stiff	200 - 400	2.0 - 4.0	15 - 30	- Can indent with thumb-nail
Hard	> 400	> 4.0	Greater than 30	- Cannot indent with thumb-nail

NOTES

1. Relative density determined by standard laboratory tests
2. N Value - blows/ft. of a 140 lb. hammer falling 30 in. on a 2 in. O.D. split spoon
3. Unconfined compressive strength = 2 x Undrained shear strength, C_u

KNIGHT PIESOLD LTD.
CONSULTING ENGINEERS

TEST PIT LOG

TEST PIT No.
TP95ME-1
SHEET 1 of 1

PROJECT Mt. Polley
LOCATION OF TEST PIT Main Embankment
DATE May 15/95

PROJECT NO. 1625
GROUND EL. _____
LOGGED BY KDE/MBS

NOTES Groundwater level difficulty in digging, equipment used, etc.	DEPTH (m)	GRAPHIC LOG	DESCRIPTION AND CLASSIFICATION OF MATERIAL
Hitachi 200 Excavator	0	+++ + + +	TOPSOIL - Dark brown/black, moist to wet SILT and SAND with ORGANICS. Slight seep at contact with Till.
	0.5	○ ○ ○ ○ + + + + ○ ○ ○ ○ + + + + ○ ○ ○ ○	GLACIAL TILL - moist, brown to grey brown, dense to very dense (increase with depth), overconsolidated SILTY SAND and GRAVEL, occasional COBBLE.
	1.0	+ + + + ○ ○ ○ ○	
	1.5	○ ○ ○ ○ + + + +	
	2.0	○ ○ ○ ○ + + + +	
SHELBY TUBE SAMPLE TP95ME-1	2.5	++++ ++++	GLACIFLUVIAL/GLACIOLACUSTRINE SEDIMENTS - Alternating layers fine SAND/SILT/fine SAND/ coarse SAND collected in shelby tube. Sand is running in excavation below glacial till. SILT layers show evidence of overconsolidation. Materials liquified while collecting shelby tube sample.
"Sand running" below till.	3.0		



PROJECT ML. Polley
LOCATION OF TEST PIT Main Embankment
DATE May 15/95

PROJECT NO. 1625
GROUND EL. _____
LOGGED BY KOE/MES

NOTES Groundwater level difficulty in digging, equipment used, etc.	DEPTH (m)	GRAPHIC LOG	DESCRIPTION AND CLASSIFICATION OF MATERIAL
Hitachi 200 Excavator			<p>TOPSOIL - Dark brown/black, moist to wet SILT and SAND with ORGANICS. Slight seep at contact with till.</p> <p>GLACIAL TILL - moist, brown to grey-brown, medium dense to dense SILTY SAND and GRAVEL, occasional COBBLE.</p>
SHELBY TUBE SAMPLE TP95ME-2A	20		<p>GLACIOFLUVIAL / GLACIOLACUSTRINE SEDIMENTS - Alternating layers of SILT / SAND / SILTY SAND. SILT sections overconsolidated, moist, with minor seep at contact with till. Medium dense to very dense. Shelby tube sample collected in dense SILT. (TP95ME-2A)</p>
Grab sample TP95ME-2B	25		<p>GLACIOFLUVIAL / GLACIOLACUSTRINE SEDIMENTS - Grey to blue grey SILT / SANDY to CLAYEY SILT. MOIST, Very dense, Overconsolidated. Grab sample collected (TP95ME-2B).</p>
	30 3.5		

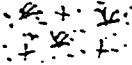
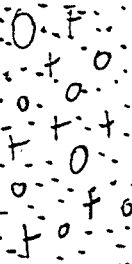
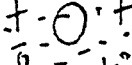
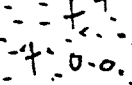
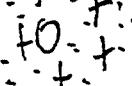
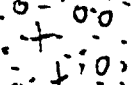
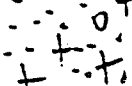
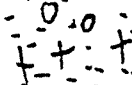
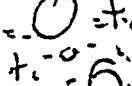
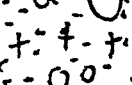
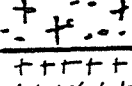
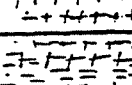
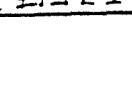

PROJECT Mt. Polley
LOCATION OF TEST PIT Main Embankment
DATE May 15/95

PROJECT NO. 1625
GROUND EL. _____
LOGGED BY KDE/MES

NOTES Groundwater level difficulty in digging, equipment used, etc.	DEPTH (M)	GRAPHIC LOG	DESCRIPTION AND CLASSIFICATION OF MATERIAL
<p>Hitachi 200 Excavator</p> <p>NOSAMPLES.</p>			<p>TOPSOIL - brown, moist SILT and SAND with SOME ORGANICS.</p>
	0.5		<p>GLACIAL TILL - moist, brown to grey- brown, dense to medium dense, (increase with depth) SILTY SAND and GRAVEL, occasional COBBLE.</p>
	1.0		
	1.5		
	2.0		
2.5			
3.0		<p>GLACIOFLUVIAL / GLACIOLACUSTRINE SEDIMENTS</p>	
3.0		<p>- From 3.0 to 3.2: moist, light brown, dense overconsolidated SILT.</p>	
3.0		<p>- From 3.2 to 3.4: moist, grey brown SILT to CLAYEY SILT, very dense, overconsolidated.</p>	
3.0			
3.0			
3.0			
3.0			
3.0			
3.0			

PROJECT Mt Polley
LOCATION OF TEST PIT Main Embankment ♀
DATE Oct. 3 / 95

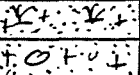
PROJECT NO. 1625
GROUND EL. _____
LOGGED BY KDE

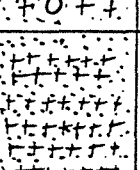
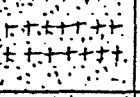
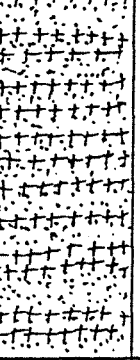
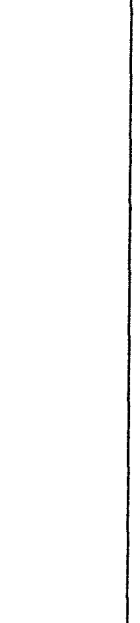
NOTES Groundwater level difficulty in digging, equipment used, etc.	DEPTH (m)	GRAPHIC LOG	DESCRIPTION AND CLASSIFICATION OF MATERIAL
Komatsu PC200LC Excavator			Topsoil - Disturbed dark brown to black, Wet SILT and fine SAND with ORGANICS.
Minor seep.			Glacial Till - Greyish green brown SILTY SAND with some GRAVEL and COBBLES. Moist to wet. Medium dense to 1.25m, dense to 2.0m. Slight seep at bottom of till unit
Minor seep in Sand layers.			Glaciolacustrine / fluvial Sediments - Greyish green brown interbedded fine SAND and SILT. Silt is stiff, overconsolidated. Sand layers seep slightly, otherwise moist.
Vertical trench walls stable.			Glaciolacustrine / fluvial Sediments - Interbedded fine SAND and SILT, as above. Color is greyish blue and unit is stiffer, SILT layers clearly overconsolidated. Moist. TD = 6.0m
Photos 1-4, 1-5			

PROJECT Mt. Polley

PROJECT NO. 1625

LOCATION OF TEST PIT Main Embankment @

GROUND EL. _____

DATE Oct 3 / 95

LOGGED BY KDE

NOTES Groundwater level difficulty in digging, equipment used, etc.	DEPTH (m)	GRAPHIC LOG	DESCRIPTION AND CLASSIFICATION OF MATERIAL
Komatsu PC200LC Excavator Minor seep from surface runoff at top of till.	0		Topsoil - Disturbed, dark brown to black, Wet, SILT and fine SAND with ORGANICS
Minor seep in occ. sand layer.	1		Glacial Till - Greenish grey brown SILTY SAND with trace to some GRAVEL and COBBLES. Moist to wet. Medium dense at top (to 1.2m), dense to very dense to 1.8m. Slight seep at top of Till.
Vertical trench walls stable.	2		Glacio lacustrine / fluvial sediments - Greenish grey brown interbedded SILT and fine SAND. Moist, stiff to very stiff. Silt is hard, overconsolidated! Occasional minor seep in sand layers.
	3		Glacio lacustrine / fluvial sediments - Interbedded SILT and fine SAND, as above. Color is greyish blue. Unit is very stiff to hard, silt clearly overconsolidated. Occasional minor seep in sand layers.
Photos 1-6, 1-7.	4 5 6 7		<p>TD = 6.5m</p>

100-116 [Cont] 1-1 5/11/7
 100-116 [Cont] 1-1 5/11/7
 100-116 [Cont] 1-1 5/11/7

PROJECT Mt. Polley

PROJECT NO. 1625

LOCATION OF TEST PIT Main Embankment E

GROUND EL. _____

DATE Oct. 3/95

LOGGED BY KDE

NOTES Groundwater level difficulty in digging, equipment used, etc.	DEPTH (m)	GRAPHIC LOG	DESCRIPTION AND CLASSIFICATION OF MATERIAL
<p>Komatsu PC200LC Excavator</p> <p>Minor inflow of water and sand, "running sand".</p> <p>Vertical trench walls stable.</p> <p>Photos 1-8, 1-9, 1-10.</p>	<p>▽ =</p>		<p>Topsoil - Disturbed dark brown to black Wet SILT and fine SAND with ORGANICS.</p>
		<p>1</p>	<p>Glacial Till - Greenish grey brown SILTY SAND with trace to some GRAVEL and COBBLES, moist to wet, medium dense to dense (at 2.0m). Medium loose at top of till.</p>
	<p>2</p>		<p>Glaciofluvial Sediments - SILTY SAND, moist brown, very stiff, overconsolidated.</p>
	<p>3</p>		<p>Glaciofluvial Sediments - Brown, fine to medium grained SAND. Wet to moist, minor amount of "running sand".</p>
	<p>4</p>		<p>Glaciofluvial Sediments - Bluish grey SILT and fine SAND. Moist, very stiff to hard, overconsolidated. Occasional SANDY layer.</p>
	<p>5</p>		<p>Trace gravel at bottom of trench.</p>
<p>6</p>		<p>TD = 6.0m</p>	
<p>7</p>			

PROJECT Mt. Polley
LOCATION OF TEST PIT Main Embankment &
DATE Oct. 3/95



PROJECT NO. 1625
GROUND EL. _____
LOGGED BY KDE

NOTES Groundwater level difficulty in digging, equipment used, etc.	DEPTH (m)	GRAPHIC LOG	DESCRIPTION AND CLASSIFICATION OF MATERIAL
Komatsu PC200LC Excavator			Topsoil - Disturbed dark brown to black wet SILT and fine SAND with ORGANICS.
Slight seep.	1		Glacial Till - Greenish grey brown SILTY SAND with trace to some GRAVEL and COBBLES. moist, medium loose to 1m, dense to very dense to 2.2m. Till is overconsolidated.
	2		Glaciofluvial Sediments - Greyish blue SILTY fine SAND with trace GRAVEL. Stiff to hard, overconsolidated. Moist.
Vertical trench walls stable	3		Glaciolacustrine / fluvial Sediments - Greyish brown very stiff to hard SILT with occasional layer of SILTY fine SAND, trace CLAY. Silt and clay are overconsolidated.
	4		Slight seep at top of unit (2.7m). TD = 5.7m
No photo.	5		
	6		
	7		

10/11/95
 R.F. [unclear]
 P. [unclear]
 1/1 3/10/95

PROJECT Mc. Polley
LOCATION OF TEST PIT Main Embankment @
DATE Oct. 3/95

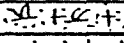
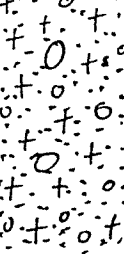
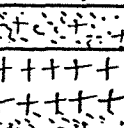
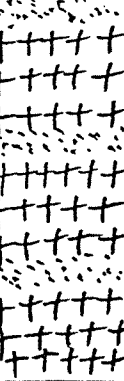
PROJECT NO. 1625
GROUND EL. _____
LOGGED BY KDE

NOTES Groundwater level difficulty in digging, equipment used, etc.	DEPTH (m)	GRAPHIC LOG	DESCRIPTION AND CLASSIFICATION OF MATERIAL
Komatsu PC200LC Excavator			Topsoil - Disturbed dark brown to black, wet SILT and fine SAND with ORGANICS.
	1		Glacial Till - Greenish grey brown SILTY SAND with trace to some GRAVEL and COBBLES. Moist, medium loose to 1.2m, dense to very dense to 2.5m. Till is overconsolidated.
Slight Seep.	2		Glaciofluvial Sediments - Greyish blue SILTY fine SAND with trace GRAVEL stiff to hard, overconsolidated, moist.
Vertical trench walls stable.	3		Glaciolacustrine / fluvial Sediments - Greyish brown very stiff to hard SILT with occasional layer of SILTY fine SAND, trace CLAY. Silt and clay are overconsolidated.
Photo 1-11, 1-12	4 5 6 7		TD = 5.8m

KDE: [unclear] 22 2007 1-1 1-12

PROJECT ML. Polley
LOCATION OF TEST PIT Main Embankment @
DATE Oct. 4/95

PROJECT NO. 1625
GROUND EL. _____
LOGGED BY KDE

NOTES Groundwater level difficulty in digging, equipment used, etc.	DEPTH (m)	GRAPHIC LOG	DESCRIPTION AND CLASSIFICATION OF MATERIAL
<p>Komatsu PC200LC Excavator</p> <p>No seeps evident. Vertical trench walls stable.</p>			<p>Topsoil - Disturbed dark brown to black wet SILT and fine SAND with ORGANICS.</p>
	1		<p>Glacial Till - Greenish grey brown SILTY SAND with trace to some GRAVEL and COBBLES. Moist to wet, medium dense. Dense at bottom of unit.</p>
	2		<p>Glacial Till - As above, with some GRAVEL and COBBLES. Hard, very dense, moist, Overconsolidated.</p>
	3		<p>Glaciolacustrine / fluvial Sediments - Greyish blue, very stiff to hard, moist SILT and fine SAND with trace GRAVEL / COBBLES. No seeps evident Overconsolidated.</p>
	4		<p>TD = 6.0m</p>
	5		
<p>Photo 1-15</p>	6		

PROJECT Mt. Polley
LOCATION OF TEST PIT Main Embankment @
DATE Oct. 4 / 95

PROJECT NO. 1625
GROUND EL. _____
LOGGED BY KOE

NOTES Groundwater level difficulty in digging, equipment used, etc.	DEPTH (m)	GRAPHIC LOG	DESCRIPTION AND CLASSIFICATION OF MATERIAL
<p>Komatsu PC200 LC Excavator</p> <p>Occ. minor seep on sandy horizons.</p> <p>Vertical trench walls stable.</p> <p>Photos 1-16, 1-17, 1-18, 1-19.</p>	<p>▽</p>		<p>Topsoil - Disturbed dark brown to black, wet SILT and fine SAND with ORGANICS.</p>
			<p>Glacial Till - Greenish grey brown SILTY SAND with trace to some GRAVEL and COBBLES. Moist to wet, medium loose to dense. Slight seep at 1.5 m</p>
			<p>Glacial Till - As above, with mottled grey blue SANDY planes. Very dense.</p>
			<p>Glaciolacustrine / fluvial Sediments - Grey brown interlayered SILT and SANDY SILT with trace CLAY. SILT layers are medium brown color and SAND is grey brown. Unit is moist, stiff, overconsolidated. Occasional minor seep on sandy horizons.</p>
			<p>TD = 6.0m</p>

PROJECT Mt. Polley

PROJECT NO. 1625

LOCATION OF TEST PIT Main Embankment @

GROUND EL. _____

DATE Oct. 4 / 95

LOGGED BY KOE

NOTES Groundwater level difficulty in digging, equipment used, etc.	DEPTH (m)	GRAPHIC LOG	DESCRIPTION AND CLASSIFICATION OF MATERIAL
Komatsu PC200LC Excavator	1		<p>Topsoil - Disturbed dark brown moist to wet SILT and fine SAND with ORGANICS.</p> <p>Glacial Till - Greenish grey brown SILTY SAND with trace to some GRAVEL and COBBLES - Moist to wet, medium loose.</p>
Slight seep at top and bottom of dense till.	2		<p>Glacial Till - As above, with blue mottled appearance. Blue mottles are SANDY horizons. Dense to very dense, moist. Overconsolidated. Slight seep at top and bottom of unit.</p>
Vertical trench walls stable.	3		<p>Glaciolacustrine/fluviol Sediments - Greyish blue SILT, SILTY SAND. Moist, stiff to very stiff. Overconsolidated. Occasional wet sand seam to 10 cm.</p>
	4		<p>Glaciolacustrine/fluviol Sediments - Brownish green interlayered SILT and fine SAND. Silt layers are muddy brown color, overconsolidated. Sandy layers are green brown color. Layers typically to 5mm.</p>
	5		<p>Moist (drier than upper unit), very stiff.</p>
	6		<p>TD=6.2m</p>
Photo 1-20.	7		

510.1
 Plot Scale 1=1
 12/1/95
 12/1/95

PROJECT Mt. Polley
LOCATION OF TEST PIT Main Embankment ϕ
DATE Oct. 4/95

PROJECT NO. 1625
GROUND EL. _____
LOGGED BY KDE

NOTES Groundwater level difficulty in digging, equipment used, etc.	DEPTH (m)	GRAPHIC LOG	DESCRIPTION AND CLASSIFICATION OF MATERIAL
Komatsu PC200LC Excavator.	1		Topsoil - Disturbed topsoil and roots for nearby burn pile. Topsoil not 1.6m thick originally.
	2		Glacial Till - Greenish grey brown SILTY SAND with trace to some GRAVEL and COBBLES. Moist, dense to approx. 2.5m and very dense to 4.1m. Slight seep at bottom of till unit.
Slight seep at bottom of till.	3		
	4		
Vertical trench walls stable.	5		Glaciolacustrine / fluvial Sediments - Greyish blue to green brown SILT and SILTY SAND. Fine, brown muddy SILT layers typically 2cm thick; SILTY SAND layers 2 to 3mm. Moist, very stiff to hard. Over-consolidated.
	6		
Photo 1-21	7		TD = 6.3m

PROJECT Mt. Polley

PROJECT NO. 1625

LOCATION OF TEST PIT Main Embankment @

GROUND EL. _____

DATE Oct. 4/95

LOGGED BY KDE

NOTES Groundwater level difficulty in digging, equipment used, etc.	DEPTH (m)	GRAPHIC LOG	DESCRIPTION AND CLASSIFICATION OF MATERIAL
<p>Komatsu PC200LC Excavator</p> <p>No seeps evident.</p> <p>Vertical trench walls stable.</p> <p>photo 1-22.</p>			<p>Topsoil - Disturbed, dark brown, moist to wet SILT and fine SAND with ORGANICS.</p>
	1		<p>Glacial Till - Greenish grey brown SILTY SAND with trace to some GRAVEL and COBBLES. Moist, Very dense, overconsolidated.</p>
	2		
	3		
	4		<p>Glaciolacustrine / fluvial Sediments - Grey brown, moist SILT and SANDY SILT. Medium stiff to stiff, overconsolidated. As above, but grey blue color, very stiff to hard. Moist, overconsolidated.</p>
	5		<p>As above, sediments with more pronounced interlayering of SILT and SANDY SILT. Very stiff to hard, moist, overconsolidated.</p>
	6		<p>TD = 6.4m</p>
7			

PROJECT Mt. Polley
LOCATION OF TEST PIT Main Embankment @
DATE Oct. 4/95

PROJECT NO. 1625
GROUND EL. _____
LOGGED BY KDE

NOTES Groundwater level difficulty in digging, equipment used, etc.	DEPTH (m)	GRAPHIC LOG	DESCRIPTION AND CLASSIFICATION OF MATERIAL
<p>Komatsu PC200LC Excavator.</p> <p>Slight seep at bottom of till.</p>			<p>Topsoil - Disturbed dark brown, moist to wet SILT and fine SAND with ORGANICS.</p>
	1		<p>Glacial Till - Greenish grey brown SILTY SAND with trace to some GRAVEL and COBBLES. Moist to wet, medium dense. Seep at bottom of till.</p>
	2		<p>Glacial Till - As above, with blue mottled appearance. Blue grey mottles are sandy horizons. Very dense, moist, overconsolidated. Mottled sandy horizons are thin (to 2mm), wet.</p>
	3		
	4		<p>Glacial Till - As above, bluish grey color, medium dense, moist to wet.</p>
	5		<p>Glaciolacustrine / fluvial Sediments - Light brown, moist SILT and SANDY SILT. Stiff to very stiff (almost hard). Mottled appearance near bottom.</p>
6		<p>TD=6.2m</p>	
<p>Photo 1-23</p>	7		

1-1
A2 F1
1-1

PROJECT Mt. Polley
LOCATION OF TEST PIT Main Embankment @
DATE Oct. 4 / 95

PROJECT NO. 1625
GROUND EL. _____
LOGGED BY KDE

NOTES Groundwater level difficulty in digging, equipment used, etc.	DEPTH (m)	GRAPHIC LOG	DESCRIPTION AND CLASSIFICATION OF MATERIAL
<p>Komatsu PC200LC Excavator</p> <p>Some "running sand!"</p> <p>Photo 1-24, 1-25.</p>	1		Topsoil - Disturbed dark brown, moist to wet SILT and fine SAND with ORGANICS.
	2		Glacial Till - Greenish grey brown SILTY SAND with trace to some GRAVEL and COBBLES. Medium loose, moist to wet.
	3		Glacial Till - As above, with bluish grey mottled appearance. Mottled horizons are wet SAND, to 2mm. Very dense, moist overall.
	4		Glaciofluvial / lacustrine Sediments - Highly irregular, intermixed layers of light brown fine to medium SAND and SILT. Unit is moist, stiff to very stiff. Silt is overconsolidated. Seep at top of unit.
	5		Glaciofluvial / lacustrine Sediments - As above, with more SAND (SILTY SAND). Sand is loose, some pockets are making water and running. Seep at top of unit.
	6		<p>TD = 6.1m</p>

PROJECT M. Polley
LOCATION OF TEST PIT Main Embankment @
DATE Oct. 4 / 95

PROJECT NO. 1625
GROUND EL. _____
LOGGED BY KDE

NOTES Groundwater level difficulty in digging, equipment used, etc.	DEPTH (m)	GRAPHIC LOG	DESCRIPTION AND CLASSIFICATION OF MATERIAL
Komatsu PC 200 LC Excavator			Topsoil - Disturbed dark brown, moist to wet SILT and fine SAND with ORGANICS.
Seep < 1gpm. "Running Sand"	1 $\frac{\nabla}{=}$		Glacial Till - Greenish grey brown SILTY SAND with trace GRAVEL and COBBLES. Medium loose, moist to wet.
Total Inflow 1-2 gpm.	2 $\frac{\nabla}{=}$		Glacial Till - As above, with bluish grey mottled appearance. Mottled horizons are wet SAND, to 2mm. Moist, dense to very dense. Seep at base of till.
	3		Glaciofluvial / lacustrine Sediments - Brown, medium grained, loose, wet SAND. Seep at 2.7m, with inflow < 1gpm and running SAND.
	4		Glaciofluvial / lacustrine Sediments - Interlayered, brown moist SILTY SAND. Stiff, overconsolidated. Occ. Sand layer loose and seeping
Photo 2-2, 2-3, 2-4.	5 6 7		Glaciofluvial / lacustrine Sediments - As above, more regularly layered SILT and SANDY SILT. Moist, stiff. TD = 7.0m

PROJECT MH. Polley



PROJECT NO. 1625

LOCATION OF TEST PIT Main Embankment @

GROUND EL. _____

DATE Oct. 4/95

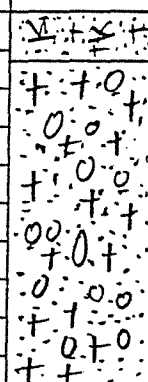
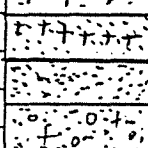
LOGGED BY KDE

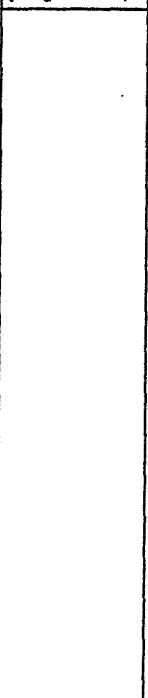
NOTES Groundwater level difficulty in digging, equipment used, etc.	DEPTH (m)	GRAPHIC LOG	DESCRIPTION AND CLASSIFICATION OF MATERIAL
Komatsu PC200LC Excavator Till quite soft.	1 2		<p>Topsoil - Disturbed dark brown, moist to wet SILT and fine SAND with ORGANICS.</p> <p>Glacial Till - Greenish grey brown SILTY SAND with trace to some GRAVEL and COBBLES. Moist to wet, medium loose/dense to 1.5m. Dense to 2.5m. Slight seep at 1.5m</p>
"Running Sand"	3		<p>Glaciolacustrine / fluvial Sediments - Interlayered light brown, stiff, moist SILT and SILTY SAND.</p> <p>Glaciofluvial / lacustrine Sediments - Brown, loose, wet sand. Seep at top, running.</p>
"Running Sand", est. water inflow, approx. 2gpm Trench collapsing in sand layers.	4 5		<p>Glaciofluvial Sediments - Brown, wet, SILTY SAND and GRAVEL.</p> <p>Glaciolacustrine / fluvial Sediments - Brown, irregular layers of medium grained, loose wet SAND and some SILT. Water seeping in sand, which is "running".</p> <p>TD = 5.7m</p>
Photo 2-5, 2-6.	6 7		

PROJECT Mt. Polley





PROJECT NO. 1625

LOCATION OF TEST PIT Main Embankment @

GROUND EL. _____

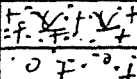
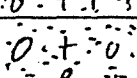
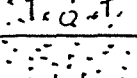
DATE Oct 4 195

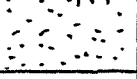
LOGGED BY KDE

NOTES Groundwater level difficulty in digging, equipment used, etc.	DEPTH (m)	GRAPHIC LOG	DESCRIPTION AND CLASSIFICATION OF MATERIAL
Komatsu PC 200 LC Excavator			Topsoil - Disturbed, dark brown, moist to wet SILT and fine SAND with ORGANICS.
Till quite wet, loose.	1		Glacial Till - Greenish grey brown SILTY SAND with trace GRAVEL and COBBLES. Moist to wet, medium loose / firm to 1.5m
Seep at base of till.	2		Glacial Till - As above, with bluish grey mottled appearance, moist to wet, medium loose to firm. Seep at base of till
"Running Sand"	3		Glaciofluvial Sediments - Light brown, wet, fine to medium SAND with occasional irregular layer of stiff, overconsolidated SILT. SAND is loose, entire unit is seeping, with "running sand". Trench sides collapsing
Trench walls collapsing.	4		"running sand". Trench sides collapsing
	5		"running sand". Trench sides collapsing
	6		TD=6.0m
Photo 2-7.	7		

PROJECT Mt. Polley
LOCATION OF TEST PIT Main Embankment E
DATE Oct 4 / 95

PROJECT NO. 1625
GROUND EL. _____
LOGGED BY KDE

NOTES Groundwater level difficulty in digging, equipment used, etc.	DEPTH (m)	GRAPHIC LOG	DESCRIPTION AND CLASSIFICATION OF MATERIAL
<p>Komatsu PC200LC Excavator</p> <p>Seeping throughout SAND. "Running SAND".</p> <p>Trench collapsed.</p> <p>No photo</p>	<p>1</p> <p>2</p> <p>∇</p>		<p>Topsoil - Dark brown, moist to wet SILT and fine SAND with ORGANICS.</p>
			<p>Glacial Till - Greenish grey brown, SILTY SAND with trace to some GRAVEL and COBBLES. Wet, medium dense loose. Slightly drier, medium dense at 2.2m</p>
	<p>3</p> <p>4</p>		<p>Glaciofluvial sediments - Brown, fine to medium SAND with occasional thin layer (to 2.5 cm) of stiff, over-consolidated SILT. Wet, loose, seeping throughout unit.</p>
			<p>Glaciolacustrine Sediments - Light brown, moist, stiff to very stiff (almost hard) SILT. TO=5.4m</p>
	<p>5</p> <p>6</p>		
		<p>7</p>	

PROJECT Mt. Polley

PROJECT NO. 1625

LOCATION OF TEST PIT Main Embankment E

GROUND EL. _____

DATE Oct. 4 / 95

LOGGED BY KDE

NOTES Groundwater level difficulty in digging, equipment used, etc.	DEPTH (m)	GRAPHIC LOG	DESCRIPTION AND CLASSIFICATION OF MATERIAL
Komatsu PC200LC Excavator	1		<p>Topsoil - Dark Brown, moist to wet SILT and fine SAND with ORGANICS.</p> <p>Glacial Till - greenish grey brown SILTY SAND with trace to some GRAVEL and COBBLES. Medium dense, moist.</p>
Random Seeps in Sand	2		<p>Glaciofluvial sediments - Brown, medium grained loose wet SAND. Seep at bottom, also randomly within unit.</p>
- Strong seep at base of gravelly unit.	3		<p>Glaciolacustrine sediments - Light brown, moist very stiff overconsolidated SILT with occasional SAND seam</p> <p>Glaciofluvial sediments - Wet, brown SANDY GRAVEL and COBBLES, very dense, seep at base of unit 2-39pm.</p>
- very hard to dig in red till	5		<p>Glacial Till - Red brown, very dense, moist SILTY SAND with some GRAVEL and COBBLES, overconsolidated. Basal till? TD = 5.7m</p>
Photos 2-8, 2-9.	6 7		

PROJECT Mt. Polley
LOCATION OF TEST PIT Main Embankment @
DATE Oct. 4/95

PROJECT NO. 1625
GROUND EL. _____
LOGGED BY KDE

NOTES Groundwater level difficulty in digging, equipment used, etc.	DEPTH (m)	GRAPHIC LOG	DESCRIPTION AND CLASSIFICATION OF MATERIAL
<p>Komatsu PC200LC Excavator</p> <p>Difficult to dig in.</p> <p>Photo 2-10</p>	<p>1</p> <p>2</p> <p>3</p> <p>4</p> <p>5</p> <p>6</p> <p>7</p>	<p>The graphic log consists of a vertical column with depth markers from 0 to 7 meters. It uses symbols to represent soil components: small circles for silt, larger circles for sand, and plus signs for gravel. The top layer (0-0.2m) is topsoil. The next layer (0.2-1.0m) is greenish-grey brown silty sand with gravel and cobbles. The layer from 1.0 to 2.0m is intermixed brown and reddish basal till. The layer from 2.0 to 3.7m is reddish brown sand and silt with gravel and cobbles. The bottom of the log is marked at 3.7m.</p>	<p>Topsoil - Dark brown, moist SILT and fine SAND with ORGANICS.</p> <p>Glacial Till - Greenish grey brown SILTY SAND with trace to some GRAVEL and COBBLES. Medium dense to dense, moist to wet. Seep at bottom.</p> <p>Glacial Till - Intermixed brown till and reddish Basal till. Moist, very dense.</p> <p>Glacial Till - Reddish brown SAND and SILT with some GRAVEL and COBBLES. Moist to wet, very dense, SANDY till</p> <p>TD = 3.7m</p>

PROJECT ML. Polley
LOCATION OF TEST PIT U/S Toe
DATE Oct. 4/95 Main Embankment

PROJECT NO. 1625
GROUND EL. _____
LOGGED BY KDE

NOTES Groundwater level difficulty in digging, equipment used, etc.	DEPTH (m)	GRAPHIC LOG	DESCRIPTION AND CLASSIFICATION OF MATERIAL
Komatsu PC 200LC Excavator Keep in sand. Hole collapsed	1 2 3 4		<p>Topsoil - Disturbed dark brown SILT and fine SAND with ORGANICS.</p> <p>Glacial Till - Greenish grey brown SILTY SAND with trace to some GRAVEL and COBBLES - Medium dense moist to wet.</p> <p>Glaciofluvial / lacustrine Sediments - Brown, fine to medium, loose, wet SAND with occasional thin layer (to 1 cm) of light brown, v. stiff, overconsolidated SILT. Water seeping in SAND unit.</p> <p>TD = 4.6m</p>
No photo.	5 6 7		

DRAWN BY: [unclear] Plot scale 1=1 500/1

PROJECT Mt. Polley
LOCATION OF TEST PIT U/S Toe
DATE Oct. 4 / 95 Main Embankment

PROJECT NO. 1625
GROUND EL. _____
LOGGED BY KOE

NOTES Groundwater level difficulty in digging, equipment used, etc.	DEPTH (m)	GRAPHIC LOG	DESCRIPTION AND CLASSIFICATION OF MATERIAL
Komatsu PC 200LC Excavator Slight seep at base of till.	0		Topsoil - Brown, moist to wet SILT and fine SAND with ORGANICS.
	1		Glacial Till - Greenish grey brown SILTY SAND with trace to some GRAVEL and COBBLES. Medium dense, moist to wet. Slight seep.
	2		Glacial Till - As above with bluish grey mottled horizons. Very dense, moist to wet (esp. on mottling).
	3		Glacial Till - Content as above, greyish blue color, very dense, moist.
Vertical trench walls stable.	4		Glaciofluvial / Glaciolacustrine Sediments - Brown, medium grained wet SAND with occasional thin, very stiff overconsolidated SILT layer. Random seeps in wet SAND.
	5		
	6		Glaciolacustrine Sediments - Light brown, moist, very stiff SILT with occasional SAND layer. TD = 6.3m
Photo 2-10	7		

PROJECT Mt. Polley
LOCATION OF TEST PIT UIS Toe
DATE Oct 4/95

PROJECT NO. 1625
GROUND EL. _____
LOGGED BY KDE

NOTES Groundwater level difficulty in digging, equipment used, etc.	DEPTH (m)	GRAPHIC LOG	DESCRIPTION AND CLASSIFICATION OF MATERIAL
Komatsu PC200LC Excavator.	1		Glacial Till - Greenish grey brown, SILTY SAND with trace to some GRAVEL AND COBBLES. Medium dense, moist to wet.
Minor seep at base of looser till unit.	2		Glacial Till - As above, with bluish grey mottled horizons; moist, dense to very dense.
Vertical trench walls stable.	3		Glacial Till - As above, bluish grey color, moist, very dense.
Vertical trench walls stable.	4		Glacial Till - As above, bluish grey color, moist, very dense.
Vertical trench walls stable.	5		Glaciolacustrine / Fluvial sediments - Brown SILTY SAND. very stiff, moist.
Vertical trench walls stable.	6		Glaciolacustrine / Fluvial sediments - Greyish Brown SILT and SILTY SAND, Wet to moist, stiff to very stiff. TD = 6.3m.
Vertical trench walls stable.	7		
Phot 2-12.			

PROJECT Mt. Polley

PROJECT NO. 1625

LOCATION OF TEST PIT D/S Toe

GROUND EL. _____

DATE Oct 5/95 Stage 1b Main Embankment

LOGGED BY KDE

NOTES Groundwater level difficulty in digging, equipment used, etc.	DEPTH (m)	GRAPHIC LOG	DESCRIPTION AND CLASSIFICATION OF MATERIAL
Komatsu PC200LC Excavator Slight seep at base of till.	0		Topsoil - Dark brown, disturbed, wet to moist SILT and fine SAND with ORGANICS.
	1		Glacial Till - Greenish grey brown SILTY SAND with trace to some GRAVEL and COBBLES. Dense to medium dense, moist, slight seep at base of unit
	2		Glacial Till - As above, but very dense.
	3		Glacial Till - As above, but bluish grey color, moist, very dense.
	4 5		Glaciolacustrine (fluvial sediments) - Light brown moist, stiff SILT. Overconsolidated. Occasional layer of loose wet fine SAND. (NOT running).
Photo 2-13.	6 7		TD = 5.9m

PROJECT Mt. Polley
LOCATION OF TEST PIT D/S Toe
DATE Oct. 5/95 Stage 1b Main Embankment

PROJECT NO. 1625
GROUND EL. _____
LOGGED BY KDE

NOTES Groundwater level difficulty in digging, equipment used, etc.	DEPTH (m)	GRAPHIC LOG	DESCRIPTION AND CLASSIFICATION OF MATERIAL
Komatsu PC200LC Excavator	1		<p>Topsoil - Disturbed dark brown, wet to moist SILT and fine SAND with ORGANICS.</p> <p>Glacial Till - Greenish grey brown SILTY SAND with trace to some GRAVEL and COBBLES. Medium dense/loose, moist to wet.</p>
	2		<p>Glacial Till - As above, except drier (moist) and dense.</p>
Slight seep in SAND unit.	3		<p>Glacio lacustrine / fluvial Sediments - Light brown, wet, fine to medium grained interlayered SAND and SANDY SILT. Occasional minor seep in sand (~5m). Wet, loose but not running; although sand is collapsing.</p>
No photo.	4 5 6 7		<p>TD=6.4m</p>

PAGE 11

PROJECT Mt. Polley

PROJECT NO. 1625

LOCATION OF TEST PIT D/S Top

GROUND EL. _____

DATE Oct. 5/95 Stage 1b Main Embankment

LOGGED BY KDE

NOTES Groundwater level difficulty in digging, equipment used, etc.	DEPTH (m)	GRAPHIC LOG	DESCRIPTION AND CLASSIFICATION OF MATERIAL
Komatsu PC200 LC Excavator	1		Topsoil - Disturbed dark brown, moist to wet SILT and fine SAND with ORGANICS.
	2		Glacial Till - Greenish grey brown with greyish mottled horizons. SILTY SAND with trace to some GRAVEL and COBBLES. Medium Dense, moist.
	3		Glacial Till - As above, but moist to wet, medium dense to loose.
Seep in gravelly unit	4		Glaciofluvial Sediments - brown, wet SAND with some GRAVEL. Medium dense to loose; seep in gravelly sections.
"Running Sand" Not as much water as embankment centre line.	5		Glaciofluvial Sediments - Medium grained, loose, wet brown SAND. Water seeping in, causing SAND to collapse and "run". Sand collapsing.
Trench collapsing	6		Glaciolacustrine Sediments - Light brown, moist, stiff interlayered SILT and SANDY SILT. TD = 6.0m
Photos Z-16, Z-17, Z-18.	7		

PROJECT Mt. Polley

PROJECT NO. 1625

LOCATION OF TEST PIT D/S top

GROUND EL. _____

DATE Oct 5/95

Stage 1b Main Embankment



LOGGED BY KDE

NOTES Groundwater level difficulty in digging, equipment used, etc.	DEPTH (m)	GRAPHIC LOG	DESCRIPTION AND CLASSIFICATION OF MATERIAL
Komatsu PC200LC Excavator	1		Topsoil - Disturbed dark brown, moist low wet SILT and fine SAND with ORGANICS.
	1		Glacial Till - Greenish grey brown SILTY SAND with trace to some GRAVEL and COBBLES. Moist, medium dense.
	2		Glacial Till - As above, with blue-grey mottled horizons (sandy coatings on rocks). Moist, very dense.
Seep in sand.	3		Glaciofluvial / lacustrine Sediments - Brown / greenish grey wet SAND with irregular patches of Brown and red glacial till. Rusty color.
	4		Glaciolacustrine / fluvial Sediments - Light brown, moist, very stiff to hard SILT and fine SAND.
Vertical trench walls stable.	5		Glaciolacustrine / fluvial Sediments - Light brown SILT and fine SAND with some GRAVEL and COBBLES. Moist, very stiff to hard TD = 5.5 m
	6		
	7		

photo 2-19.

PROJECT Mt. Polley
LOCATION OF TEST PIT D/S toe
DATE Oct 5/95 Final Main Embankment

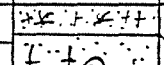
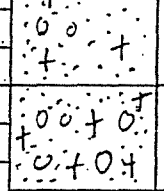
PROJECT NO. 1625
GROUND EL. _____
LOGGED BY KDE

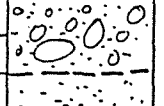
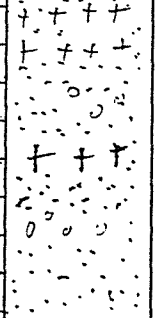
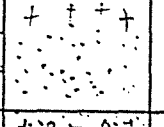
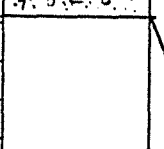
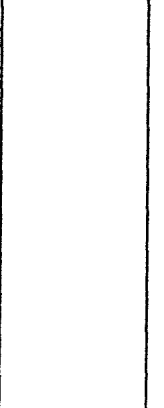
NOTES Groundwater level difficulty in digging, equipment used, etc.	DEPTH (m)	GRAPHIC LOG	DESCRIPTION AND CLASSIFICATION OF MATERIAL
Komatsu PC200LC Excavator			Topsoil - Dark brown, moist to wet SILT and fine SAND with ORGANICS.
	1		Glacial Till - Greenish grey brown SILTY SAND with trace to some GRAVEL and COBBLES. Medium dense, moist.
	2		Glacial Till. As above, with blue-grey mottling. Moist, very dense (overconsolidated).
Strong seep in coarse sediments.	3		Glacioluvial Sediments - Brown, wet, medium loose medium grained SAND.
	4		Glacioluvial Sediments - Brown, wet SAND, GRAVEL and COBBLES. Dense to very dense. Strong seep, approx. 2-3 gpm. Coarse material extends to approx 3.5m. Below 3.5m, SAND with some SILT, GRAVEL.
	5		
	6		
photo 2-20.	7		Brown, moist SILTY SAND and GRAVEL. Dense to very dense. Probably glacial till TD = 6.7m

PROJECT Mt. Polley
LOCATION OF TEST PIT D/S Toe
DATE _____ Final Main Embankment

PROJECT NO. 1625
GROUND EL. _____
LOGGED BY KDE

NOTES Groundwater level difficulty in digging, equipment used, etc.	DEPTH (m)	GRAPHIC LOG	DESCRIPTION AND CLASSIFICATION OF MATERIAL
Komatsu PC200LC Excavator Trench staying open.	1		Topsoil - Dark brown, moist to wet SILT and fine SAND with ORGANICS. Lots of Roots - Glacial Till - Greenish grey brown SILTY SAND with trace to some GRAVEL and COBBLES. Moist, medium dense
	2		Glacial Till - As above, but moist, dense to very dense. Occasional SAND LENS.
	3		Glaciofluvial Sediments - Green brown SILTY SAND with trace GRAVEL. Wet, medium dense to loose.
	5		Glaciofluvial Sediments - Brown, loose wet SAND with water seeping, minor "running SAND" TD = 5.9m
	7		

Photo 2-21

1.0
2.0
3.0
4.0
5.0
6.0
7.0
8.0
9.0
10.0

PROJECT Mt. Polley
LOCATION OF TEST PIT D/S Tor
DATE Oct. 5/95 Final Main Embankment

PROJECT NO. 1625
GROUND EL. _____
LOGGED BY KDE

NOTES Groundwater level difficulty in digging, equipment used, etc.	DEPTH (m)	GRAPHIC LOG	DESCRIPTION AND CLASSIFICATION OF MATERIAL
<p>Komatsu PC200LC Excavator</p> <p>Water seeping in sand horizon.</p> <p>Photo 2-22</p>			<p>Topsoil - Black, wet SILT and fine SAND with lots of ORGANICS (peat).</p>
	1		<p>Glacial Till - Bluish grey SILTY SAND with trace to some GRAVEL and COBBLES. Wet, firm (color due to overlying organics).</p>
	2		<p>Glacial Till - Greenish grey brown. Composition as above. Medium dense to dense, moist to wet. One boulder 1.5m diameter.</p>
	4		<p>Glaciofluvial Sediments - Brown, medium loose, wet SAND. Water seeping in, Sand collapsing badly.</p>
	5		<p>Glaciofluvial Sediments - Brown, loose wet SAND with occasional layer (1 to 2cm) of overconsolidated SILT.</p>
	6		<p>Glaciolacustrine Sediments - Interlayered light brown fine SILTY SAND and muddy brown overconsolidated SILT. Wet, stiff. TD = 6.2m</p>
	7		

PROJECT Mt. Polley

PROJECT NO. 1625

LOCATION OF TEST PIT D/S Toe

GROUND EL. _____

DATE Oct 5/95 Final Main Embankment

LOGGED BY KDE

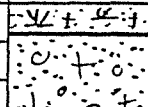
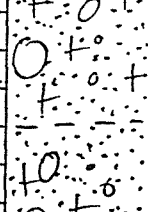
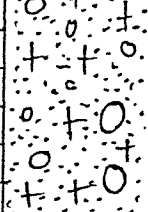
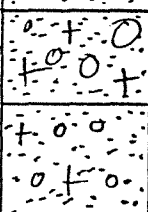
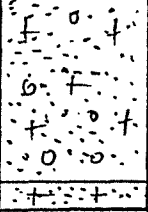
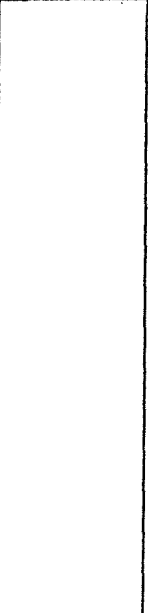
NOTES Groundwater level difficulty in digging, equipment used, etc.	DEPTH (m)	GRAPHIC LOG	DESCRIPTION AND CLASSIFICATION OF MATERIAL
Komatsu PC 200LC Excavator			Topsoil - Dark brown, moist to wet SILT and fine SAND with ORGANICS.
Slight seep in fill	▽ =		Glacial Till - Greenish grey brown SILTY SAND with trace to some GRAVEL and COBBLES. Moist to wet, medium dense to dense (at bottom). Slight seep in fill approx 1.5m (down)
			Glacial Till - As above, blue grey color, SANDY, wet, medium dense.
			Glacial Till - Greenish grey brown color, as above. SILTY SAND with trace GRAVEL, over- consolidated. (maybe sediments), Moist to wet, dense. Slight seep.
Seep in sand.	▽ =		Glaciolacustrine sediments - Interlayered light brown fine SILTY SAND and muddy brown overconsolidated SILT. Moist, stiff. TD=6.2m.
Photo 2-23			

PROJECT MH. Polley
LOCATION OF TEST PIT D/S Toe
DATE Oct 5/95 Final Main Embankment

PROJECT NO. 1625
GROUND EL. _____
LOGGED BY KDE

NOTES Groundwater level difficulty in digging, equipment used, etc.	DEPTH (m)	GRAPHIC LOG	DESCRIPTION AND CLASSIFICATION OF MATERIAL
<p>Komatsu PC200LC Excavator</p> <p>Minor seep at base of looser fill.</p>	0		<p>Topsoil - Disturbed dark brown moist to wet SILT and fine SAND with ORGANICS.</p>
	1		<p>Glacial Till - Greenish grey brown SILTY SAND with trace to some GRAVEL and COBBLES. Moist, dense. Minor seep.</p>
	2		<p>Glacial Till - As above. Moist, very dense.</p>
	3		<p>Glaciolacustrine / fluvial Sediments - Interlayered, brown, moist SILT and SILTY SAND. Very stiff.</p>
	4		<p>Glaciofluvial / lacustrine Sediments - Brown, wet, medium grained SAND with trace SILT. Medium dense to loose. Water held in sand, not seeping or running.</p>
	5		<p>Glaciolacustrine Sediments - Light brown, moist SILT and SILTY SAND. Stiff / very stiff.</p>
	6		<p>TD = 6.3m</p>

Photo Z-24



PROJECT Mt. Polley
LOCATION OF TEST PIT D/S Top
DATE Oct 5/95 Final Main Embankment

PROJECT NO. 1625
GROUND EL. _____
LOGGED BY KDE

NOTES Groundwater level difficulty in digging, equipment used, etc.	DEPTH (m)	GRAPHIC LOG	DESCRIPTION AND CLASSIFICATION OF MATERIAL
Komatsu PC200LC Excavator			<p>Topsoil - Disturbed brown/black, moist to wet SILT and fine SAND with ORGANICS.</p> <p>Glacial Till - Greenish grey brown SILTY SAND with trace to some GRAVEL and COBBLES. Moist to wet, medium dense to dense at bottom.</p>
Slight Seep	2		<p>Glacial Till - As above, with bluish grey mottled horizons, which are sandy coatings. Moist to wet, very dense.</p>
Slight Seep.	3		<p>Glacial Till - as above, bluish grey with some COBBLES and GRAVEL. Moist, very dense.</p>
	4		<p>Glaciofluvial / lacustrine sediments - Brown, wet, medium grained SAND with trace SILT. Occasional silt pocket - Medium loose.</p>
Photo 2-25	5		<p>Glaciolacustrine sediments - Light brown, moist SILT and SILTY SAND - stiff to very stiff TD = 6.2m</p>
	6		
	7		

PROJECT Mt. Polley
LOCATION OF TEST PIT Seepage Pond, NE corner
DATE Sept 21/95 (S.O.P. 519)

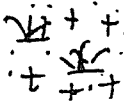
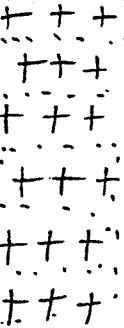
PROJECT NO. 1625
GROUND EL. _____
LOGGED BY KDE

NOTES Groundwater level difficulty in digging, equipment used, etc.	DEPTH (m)	GRAPHIC LOG	DESCRIPTION AND CLASSIFICATION OF MATERIAL
JD-690D LC Excavator Occ. seep, >> 1gpm.	0 1 2		Dark brown, wet, loose SILT and fine SAND with ORGANICS. (TOPSOIL). Bluish grey to brown, moist to wet, dense to very dense SILTY SAND with some GRAVEL, occ. COBBLE. Over-consolidated. (GLACIAL TILL)
	3 4		Grey-green to green brown, moist, very stiff SILT with trace fine SAND. Uniform, glacioluvial / glaciolacustrine sediments. Occasional seep. Over consolidated
	5		

2000-10-12 10:00 AM

PROJECT Mt. Polley
LOCATION OF TEST PIT See page Collection Pond
DATE Oct. 5/95 15m west of S20

PROJECT NO. 1625
GROUND EL. _____
LOGGED BY KDE

NOTES Groundwater level difficulty in digging, equipment used, etc.	DEPTH (m)	GRAPHIC LOG	DESCRIPTION AND CLASSIFICATION OF MATERIAL
Komatsu PC200HC Excavator Slight seep.	0		Topsoil - Disturbed dark brown, black moist to wet SILT and fine SAND with ORGANICS.
Hold almost dry.	1		Glacial Till - Greenish grey brown SILTY SAND with trace to some GRAVEL and COBBLES. Has bluish grey mottled horizons which are wet. Overall, moist to wet, medium dense to 1.5m and medium dense to dense at bottom. Slight seep on mottled surfaces
Vertical trench walls stable.	2		Glaciolacustrine / Fluvial Sediments - Brown, moist to wet SAND and SILTY SAND. Stiff to firm.
Photo 3-1	3		Glaciolacustrine / Fluvial Sediments - As above, but greyish brown color, moist, stiff. TD=6.4m
	4		
	5		
	6		
	7		

PROJECT Mt. Polley

PROJECT NO. 1625

LOCATION OF TEST PIT Seepage Collection Pond

GROUND EL. _____

DATE Oct 5/95

Between 520 / 521.

LOGGED BY KDE

NOTES Groundwater level difficulty in digging, equipment used, etc.	DEPTH (m)	GRAPHIC LOG	DESCRIPTION AND CLASSIFICATION OF MATERIAL
Komatsu PC 200LC Excavator			Topsoil - Disturbed brown/black, moist to wet SILT and fine SAND with ORGANICS.
Minor seep on sandy crack in till	1 2		Glacial Till - Greenish grey brown SILTY SAND with trace to some GRAVEL and COBBLES. Moist, dense
	3 4		Glaciolacustrine / Fluvial Sediments - Interlayered light brown SILT and SILTY SAND. Moist to wet (at sandy horizons).
Vertical trench walls stable	5 6		Glaciolacustrine / Fluvial Sediments - As above, greyish color. TD = 6.5m
Photo 3-2	7		

PROJECT Mt. Polley
LOCATION OF TEST PIT Seepage Pond, SW corner
DATE Sept 21/95 (S.O.P. S21)

PROJECT NO. 1625
GROUND EL. _____
LOGGED BY KDE

NOTES Groundwater level difficulty in digging, equipment used, etc.	DEPTH (m)	GRAPHIC LOG	DESCRIPTION AND CLASSIFICATION OF MATERIAL
JD 690D-LC excavator			Dark brown, moist, loose SILT and fine SAND with ORGANICS. (TOPSOIL) Brownish grey, moist and dense SILTY SAND / SILT with trace to some GRAVEL, trace COBBLES, occ. BOULDER. (GLACIAL TILL)
Water seeping in sandy sediments.	▽		Brown, loose, very wet medium grained SAND with trace SILT (Birds together). Unstable, sides of trench collapsing. Water seeping in. (Glacio fluvial / Glaciolacustrine sediments.)
Entire trench collapsed. No samples, no photos.	3		Brown, medium dense, moist to wet layered SILT and fine SAND, trace CLAY, Over- consolidated. (Glacio fluvial / Glaciolacustrine sediments).
	4 5		

PREP. 10 P. 1-1

PROJECT Mt. Polley

PROJECT NO. 1625

LOCATION OF TEST PIT Seepay Collection Pond

GROUND EL. _____

DATE Oct 5/95 East of S21

LOGGED BY KDE

NOTES Groundwater level difficulty in digging, equipment used, etc.	DEPTH (m)	GRAPHIC LOG	DESCRIPTION AND CLASSIFICATION OF MATERIAL
Komatsu PC 200 LC Excavator		+ 0 +	Topsoil - Disturbed dark brown SILT and fine SAND with ORGANICS. WET to MOIST.
	1	+ 0 + + 0 + + 0 + + 0 +	Glacial Till - Greenish grey brown SILTY SAND with trace to some GRAVEL and COBBLES, moist to wet, medium dense.
	2	+ + + + + + + + + + + +	Glaciolacustrine (fluvial sediments) - brown, moist to wet fine SAND and SILT, Firm to stiff.
	3	+ + + + + + + + +	Glaciolacustrine (fluvial sediments) - Blue grey interlayered SAND (fine) and SILT. Occasional seam of muddy brown stiff overconsolidated SILT/CLAY.
	4	+ + + + + + + + +	Moist to wet, firm to stiff.
	5	+ + + + + + + + +	
Vertical trench walls stable.	6	+ + +	Glaciolacustrine sediments - Light brown, interlayered SILT and fine SAND. moist, stiff TD = 6.0m
Photo 3-3	7		

PROJECT Mt. Polley
LOCATION OF TEST PIT Seepage Pond, SE corner
DATE Sept 21/95 (S.O.P. 522)

PROJECT NO. 1625
GROUND EL. _____
LOGGED BY KDE

NOTES Groundwater level difficulty in digging, equipment used, etc.	DEPTH (m)	GRAPHIC LOG	DESCRIPTION AND CLASSIFICATION OF MATERIAL
<p>JD 690D-LC Excavator</p> <p>Occ. small seep in bluish layer >> 1gpm.</p>	<p>▽ =</p>	<p>+ + + + + + + + + + + + + + +</p>	<p>Dark brown, wet, loose SILT and Fine SAND with ORGANICS (TOPSOIL).</p>
	<p>1</p>	<p>+ + + + + + + + + + +</p>	<p>Greenish-grey to brown, moist, medium dense SILT/SILTY SAND with trace to some GRAVEL. (GLACIAL TILL).</p>
	<p>▽ 2</p>	<p>+ + + + + + + + + + + + + + + + + + + +</p>	<p>Mottled green grey to brown SILT and SILTY fine SAND. Very stiff, moist. mottled appearance due to the presence of randomly oriented grey-blue layers of fine SILT and CLAY with trace SAND and GRAVEL. Layers seep a small amount of water. Dense, over-consolidated GLACIOFLUVIAL / GLACIO-LACUSTRINE SEDIMENTS-</p>
	<p>▽ 3</p>	<p>+ + + + + + + + + + + + + + + +</p>	<p>4</p>
	<p>▽ 5</p>	<p>+ + + + + + + + + + + +</p>	<p>Greyish Blue, moist, very stiff SILT and CLAY with trace SAND. Over-consolidated. Minor seep. Similar to above glaciofluvial / glaciolacustrine sediments.</p>

