

**IMPERIAL METALS CORP.
MT. POLLEY PROJECT**

**TAILINGS STORAGE FACILITY
DESIGN REPORT
(REF. NO. 1625/1)**

VOLUME I - MAIN REPORT

MAY 26, 1995

Knight Piésold
CONSULTING ENGINEERS

14745-40/MTP0/01

TE
MINISTRY OF ENERGY, MINES
AND PETROLEUM RESOURCES
REC'D OCT 1 11 1995
MINE REVIEW AND PERMITTING
BRANCH

**IMPERIAL METALS CORP.
MT. POLLEY PROJECT**

**TAILINGS STORAGE FACILITY
DESIGN REPORT
(REF. NO. 1625/1)**

VOLUME I - MAIN REPORT

MAY 26, 1995

MP00001

Suite 1400
750 West Pender Street
Vancouver, British Columbia
Canada V6C 2T8
Telephone (604) 685-0543
Telefax (604) 685-0147
CIS: 72360,477

Knight Piésold Ltd.
CONSULTING ENGINEERS

GRIT 2158

IMPERIAL METALS CORPORATION
MT. POLLEY PROJECT

TAILINGS STORAGE FACILITY
DESIGN REPORT
(REF. NO. 1625/1)

TABLE OF CONTENTS

	<u>PAGE</u>
SECTION 1.0 INTRODUCTION	1
1.1 PROJECT DESCRIPTION	1
1.2 SCOPE OF REPORT	2
SECTION 2.0 SITE CHARACTERISTICS	4
2.1 HYDROMETEOROLOGY	4
2.1.1 General	4
2.1.2 Precipitation and Evaporation	4
2.1.3 Runoff Coefficients	5
2.1.4 Storm Events	6
2.2 REGIONAL GEOLOGY	6
2.3 SEISMICITY	7
2.3.1 Regional Seismicity	7
2.3.2 Seismic Design Parameters	8
SECTION 3.0 TAILINGS CHARACTERISTICS	11
3.1 PROCESS DESCRIPTION	11
3.2 PHYSICAL CHARACTERISTICS	11
3.3 GEOCHEMICAL CHARACTERISTICS	12
SECTION 4.0 SITE SELECTION	14
SECTION 5.0 GEOTECHNICAL CONDITIONS	16



5.1	SITE INVESTIGATIONS	16
5.2	CONSTRUCTION MATERIALS	16
5.2.1	General	16
5.2.2	Laboratory Testwork	16
5.3	TAILINGS IMPOUNDMENT	19
SECTION 6.0	TAILINGS FACILITY DESIGN	21
6.1	DESIGN CRITERIA	21
6.1.1	General	21
6.1.2	Design Basis	21
6.1.3	Construction Schedule	22
6.1.4	Site Layout and Operating Strategy	24
6.1.5	Tailings Storage Capacity	26
6.1.6	Reclaim Water Storage Capacity	27
6.1.7	Staged Development	28
6.2	TAILINGS IMPOUNDMENT PREPARATION	30
6.2.1	Clearing and Topsoil Stockpiling	30
6.2.2	Liner Design and Extent	30
6.2.3	Sediment Control Structures	32
6.3	EMBANKMENT CONSTRUCTION	33
6.3.1	General	33
6.3.2	Geotechnical Considerations	33
6.3.3	Borrow Areas	35
6.3.4	Stage Ib Construction	36
6.3.5	Embankment Drainage Provisions	37
6.3.6	Staged Expansions	39
6.4	QA/QC PROCEDURES	40
6.5	TAILINGS CONSOLIDATION ANALYSES	41
6.5.1	General	41
6.5.2	Parameters and Assumptions	42
6.5.3	Results	43
6.6	EMBANKMENT SETTLEMENT	43
6.6.1	General	43
6.6.2	Results	44



6.7	STABILITY ANALYSES	46
6.7.1	General	46
6.7.2	Material Parameters and Assumptions	48
6.7.3	Results of Analyses	49
SECTION 7.0	SEEPAGE ANALYSES	53
7.1	GENERAL	53
7.2	SUMMARY OF PARAMETERS	53
7.3	BOUNDARY CONDITIONS AND FLUX SECTIONS	54
7.4	RESULTS	55
SECTION 8.0	WATER BALANCE AND MANAGEMENT	57
8.1	GENERAL	57
8.2	WATER BALANCE	58
8.2.1	General	58
8.2.2	Water Balance Results	59
8.2.3	Water Supply at Start-Up	60
8.3	WATER MANAGEMENT PLAN	61
8.3.1	General	61
8.3.2	Surface Runoff Diversion Ditches	62
8.3.3	Sediment Control Ponds and Discharge Requirements	64
SECTION 9.0	PIPEWORK	65
9.1	GENERAL	65
9.2	TAILINGS PIPEWORK	65
9.2.1	General	65
9.2.2	Design Criteria	65
9.2.3	Tailings Delivery Pipework	66
9.2.4	Tailings Discharge Pipeline	67
9.3	RECLAIM WATER SYSTEM	68
9.3.1	General	68
9.3.2	Design Criteria	68



	9.3.3	Reclaim Barge	68
	9.3.4	Reclaim Pipelines	69
	9.3.5	Reclaim Booster Pump Station	69
9.4		SEEPAGE RECOVERY SYSTEM	69
	9.4.1	Monitoring Wells	69
	9.4.2	Basin Groundwater and Embankment Foundation Drains	70
	9.4.3	Toe Drain	70
	9.4.4	Drain Monitoring Sump	70
	9.4.5	Seepage Collection Pond Recycle Pumps	71
SECTION 10.0		OPERATION AND MONITORING	72
	10.1	GENERAL	72
	10.2	INSTRUMENTATION	73
SECTION 11.0		RECLAMATION	75
	11.1	GENERAL	75
	11.2	TOPSOIL STOCKPILING	76
	11.3	DECOMMISSIONING AND CLOSURE	76
SECTION 12.0		REFERENCES	79

TABLES

Table 2.1	Mean Monthly and Annual Precipitation
Table 2.2	Precipitation Details Used in Analysis
Table 2.3	Estimated Pan Evaporation at Site
Table 2.4	Probable Maximum Precipitation
Table 2.5	Usual Minimum Criteria for Design Earthquakes
Table 5.1	Summary of Laboratory Tests - Index Test Results
Table 5.2	Summary of Laboratory Tests - Effective Strength Parameters Compaction and Permeability Test Results
Table 6.1	Summary of Design Criteria



Table 6.2	Consequence Classification of Dams
Table 6.3	Staged Embankment Fill Quantities
Table 7.1	Summary of Material Parameters for Seepage Analyses
Table 7.2	Summary of Seepage Analysis Results

FIGURES

Figure 1.1	Project Location Map
Figure 2.1	Location of Weather Stations
Figure 2.2	Short Duration Rainfall Intensity-Duration-Frequency Data for Mine Site
Figure 4.1	Tailings Area Alternatives
Figure 6.1	Stage Ib Construction Schedule
Figure 6.2	Depth / Area / Capacity Filling Rate for Tailings Storage Facility
Figure 6.3	Tailings Area Filling Schedule and Staged Construction
Figure 6.4	Supernatant Pond Depth/Area Capacities for 0.5% Sloped Tailings Surface
Figure 6.5	Embankment Fill Borrow Areas
Figure 6.6	Embankment Settlement Analyses
Figure 6.7	Embankment Stability Analyses - Geometry and Material Parameters
Figure 6.8	Embankment Stability Analyses - Static Stability At Closure
Figure 6.9	Embankment Stability Analyses - Static Stability After Closure
Figure 6.10	Embankment Stability Analyses - Pseudostatic Stability During Operations
Figure 6.11	Embankment Stability Analyses - Pseudostatic Stability After Closure
Figure 6.12	Embankment Stability Analyses - Undrained Residual Strength Stability
Figure 6.13	Embankment Stability Sensitivity Analyses
Figure 6.14	Upstream Embankment Stability Analyses
Figure 7.1	Seepage Analysis Cross - Sections
Figure 7.2	Seepage Flow Development - Main Embankment



Figure 7.3	Seepage Flow Development - Perimeter Embankment
Figure 7.4	Seepage Flow Development - South Embankment
Figure 8.1	Site Water Management Schematic
Figure 8.2	Annual Water Balance Schematic - Average Year - Year 1
Figure 8.3	Annual Water Balance Schematic - Average Year - Year 14

DRAWINGS

1625.100 Rev.1	Tailings Storage Facility - Overall Site Plan
1625.101 Rev.1	Tailings Storage Facility - Foundation Preparation and Basin Liner
1625.102 Rev.1	Tailings Storage Facility - Foundation Preparation and Basin Liner - Sections and Details
1625.110 Rev.1	Tailings Storage Facility - Stage Ib Tailings Impoundment - General Arrangement
1625.111 Rev.1	Tailings Storage Facility - Tailings Embankment - Sections and Details
1625.112 Rev.1	Tailings Storage Facility - Sediment Control and Seepage Collection
1625.113 Rev.1	Tailings Storage Facility - Sediment Control and Seepage Collection - Sections and Details
1625.114 Rev.1	Tailings Storage Facility - Surface Water Control - Plan and Profile
1625.115 Rev.1	Tailings Storage Facility - Surface Water Control - Sections and Details
1625.116 Rev.1	Tailings Storage Facility - Tailings Distribution and Reclaim System - Plan and Profile
1625.117 Rev.1	Tailings Storage Facility - Tailings Distribution and Reclaim System - Sections and Details
1625.118 Rev.0	Tailings Storage Facility - Surface Water Control - Flow Control Structures - Concrete Details
1625.120 Rev.1	Tailings Storage Facility - Instrumentation
1625.121 Rev.0	Tailings Storage Facility - Instrumentation - Sections and Details
1625.130 Rev.1	Tailings Storage Facility - Final Arrangement
1625.140 Rev.1	Tailings Storage Facility - Reclamation Plan



APPENDICES

Appendix A	Report on Project Water Management (Ref. No. 1624/1)
Appendix B	Geotechnical Investigation Information
Appendix C	Testwork on Tailings - Physical and Geochemical Characteristics



IMPERIAL METALS CORPORATION
MT. POLLEY PROJECT

TAILINGS STORAGE FACILITY
DESIGN REPORT
(REF. NO. 1625/1)

SECTION 1.0 - INTRODUCTION

1.1 PROJECT DESCRIPTION

The Mt. Polley project is located in central British Columbia approximately 56 kilometres north-east of Williams Lake, as shown on Figure 1.1. The nearest settlement is the community of Likely, which is located on the northern tip of Quesnel Lake.

The project derives its name from Mt. Polley, a low mountain with a peak elevation of 1260 metres, approximately 300 metres above the surrounding terrain. Mt. Polley is situated on a topographic ridge with Polley Lake to the east and Bootjack Lake to the south-west. The site is accessible by paved road from Williams Lake to Morehead Lake, near Likely, and then by gravel forestry road for the final 10 kilometres to the site.

The Mt. Polley project involves open pit mining of an estimated 48.8 million tonnes of copper and gold ore contained in three ore bodies. The ore will be hauled from the open pit to the crushers where it will be crushed and transported to the nearby concentrator for processing. The ore will be processed by selective flotation to produce a copper-gold concentrate at a production rate of approximately 13,425 tonnes per day (approximately 5 million tonnes per year). An additional 26.2 million tonnes of low grade ore will be stockpiled during operations for processing in the later stages of the mine life.

After processing of the ore to produce the copper/gold concentrate, the tailings will be discharged as a slurry into the tailings storage facility which has been designed to



provide environmentally secure storage of the solid waste. As the solids settle out of the slurry, process fluids are collected and recycled back to the mill for re-use in the milling process. No surface discharge of any process solution from the tailings facility is required or anticipated.

1.2 SCOPE OF REPORT

This report presents the tailings storage facility design, which is based on the results of field investigations and laboratory testwork. Specific design items which are addressed in the report include:

- Site characteristics including hydrometeorology, regional geology and seismicity.
- Process description and results of physical and geochemical testwork on the tailings.
- Site selection criteria.
- The results of geotechnical investigations carried out at the tailings storage facility location.
- Evaluation of the tailings storage facility foundations and identification of construction materials.
- General design features including geotechnical considerations, water balance and initial process water supply requirements, operating requirements, on-going construction and final reclamation.

The tailings storage facility presented herein will operate as a valley impoundment for the first year of operation. In its final configuration, the tailings storage facility will comprise a side-hill impoundment centred 5 km south-east of the orebodies. The overall site plan is shown on Dwg. No. 1625.100.



The tailings storage facility is a lined impoundment with a partial basin groundwater underdrain, zoned earthfill embankments, seepage collection ponds, surface runoff diversion ditches and flow control structures, sediment control structures, tailings distribution system, and water reclaim system.

The tailings embankment has been designed to operate as a process water collection dam for one year prior to mill start-up. Tailings will be discharged from the embankment starting in late 1996 or early 1997. The embankment crest will be raised progressively throughout the life of the project. Excess water from the catchment areas will be diverted to maintain a water balance that will not require discharge of process water to the environment.



SECTION 2.0 - SITE CHARACTERISTICS

2.1 HYDROMETEOROLOGY

2.1.1 General

Long and short term climate records are available for a number of locations in the general mine site area, as shown on Figure 2.1. Two recently established stations (Likely with 6 years of record and Horsefly with 11 years) are located in similar terrain within 40 km of the site. The project area is subject to a relatively temperate climate with warm summers and cool winters. The precipitation is well distributed throughout the year.

The mean annual temperature at Likely, the nearest station, is 4.0°C with an extreme maximum of 33.9°C and an extreme minimum of -37°C. At Quesnel, with approximately 70 years of record, extremes are 40.6°C and -46.7°C. Frost free days in the area range from 199 at Horsefly Lake (elevation 788 m) to 244 at Barkerville (elevation 1244 m).

2.1.2 Precipitation and Evaporation

Hydrometeorological information for the project was recently summarized in "Report on Project Water Management", which is included in Appendix A in its entirety.

Since precipitation data at the site is limited, mean precipitation records for climatologically similar stations in the area were used to estimate a mean annual site precipitation of 755 mm. The mean annual precipitation at Likely is 699.7 mm and at Barkerville (with over 70 years of record) is 1043.9 mm. Precipitation for the site can be expected to fall within this range. Data for Likely, Barkerville and the site are presented in Table 2.1. A coefficient of variation of 0.16 was determined from regional values which translates to a standard deviation of 121 mm. These conditions were applied to the tailings facility and adjacent additional tailings catchment areas.



For the water management plan, the waste dumps, pit areas and mill site, all at higher elevations, were modelled with a mean precipitation of 810 mm, a coefficient of variation of 0.16 and a standard deviation of 130 mm. The increased precipitation value is consistent with elevation correlations developed in previous studies. This data is summarized on Table 2.2.

Evaporation data and estimated evaporation for the site have been computed using potential evapotranspiration by AES using the Thornwaite model and available data for Quesnel and Williams Lake. This data is shown in Table 2.3. The annual evaporation rate of 423 mm at the site has been assumed to be constant for all years of operation and precipitation conditions.

2.1.3 Runoff Coefficients

Runoff coefficients used for the water balances include variable runoff coefficients based on dry, average and wet years. Dry years were defined as years when the total precipitation was less than or equal to 1.3 standard deviations below the mean (10 year dry), and wet years were defined as years when the total precipitation was at least 1.3 standard deviations above the mean (10 year wet). Runoff coefficients are summarized below:

Component Description	Runoff Coefficient (%)		
	Dry	Average	Wet
Unprepared Tailings Basin	20	24	29
Prepared Tailings Basin	90	90	90
Tailings Beach	90	90	90
Open Pit	45	50	55
Mill Site	65	70	75
Waste Rock Dumps	58	60	62
Undisturbed Catchments	20	24	29



2.1.4 Storm Events

Intensity-duration-frequency curves have been developed for the site on the basis of data obtained from the Rainfall Frequency Atlas for Canada (RFAC), and these are shown on Figure 2.2. Probable maximum precipitation values for the site have also been calculated, and these are shown in Table 2.4. As outlined in the RFAC the 1 and 6 hour values are not influenced by orographic factors, while the 24 hour and 10 day values are significantly affected. The RFAC states that an orographic factor of 1.5 should be used for durations greater than 12 hours and elevations greater than 800 m. This is a very general rule and as the site is at an elevation of approximately 1000 m, and as orographic influences tend to increase with elevation, it can be argued that a factor of somewhere between 1 and 1.5 would be more appropriate. However, for the sake of conservatism, a value of 1.5 was used.

The 10 day PMP was estimated by assuming a ratio of 10 day to 1 day PMP of 2.0. Regional long duration extreme precipitation values are currently not available from AES (Atmospheric Environment Services) and therefore it is not possible to accurately determine 10 day PMP values. However, based on a number of PMP studies in the U.S., and considering the conservativeness of the 24 hr PMP value, a ratio of 2.0 was considered reasonable and appropriate for estimating the 10 day PMP value of 406 mm. This value was used for evaluation of embankment storage requirements.

*Doubled
1 day*

2.2 REGIONAL GEOLOGY

The Mt. Polley site is located in an alkalic intrusive complex in the Quesnel Trough, a 35 km wide north-west trending volcanic sedimentary belt of regional extent.

The rock units are segmented into blocks by several faults, including an inferred north westerly trending normal fault which extends along Polley Lake. The



predominant structure of the region is north-west trending and dipping steeply to the north-east.

The topography is generally subdued and has been glaciated. Surficial deposits of well graded dense glacial till material are common throughout the region and are typically present in greater thicknesses in topographic lows. Bedrock exposures are common at higher elevations.

Detailed descriptions of both bedrock and overburden geology are presented in Section 5.0, as well as Appendix B1 "Report on 1995 Geotechnical Investigations for Mill Site and Tailings Storage Facility". Additional drillhole logs obtained from the 1990 geotechnical site investigation are included in Appendix B2.

2.3 SEISMICITY

2.3.1 Regional Seismicity

The Mt. Polley project is situated within the interior of B.C., an area that historically is of low seismicity. The site is located within the Northern B.C. source zone (NBC), close to the boundary with the Southeastern B.C. source zone (SBC), as defined by Basham et al (1982). Basham assigns a maximum earthquake magnitude of 5.0 for the NBC zone, being one-half magnitude unit above the observed maximum magnitude of 4.5. Similarly, a maximum magnitude of 6.5 has been set for the SBC zone, based on historic earthquake data.

There has been much debate in recent years concerning the possibility of a large interplate earthquake of magnitude 8 or 9 along the Cascadia subduction zone. However, such an event would be located at over 400 km west of the project site. Southwest of the site lies the Northern Cascades region where a maximum earthquake magnitude of 7.5 has been estimated, based on historic seismic records and geologic data (Leader Lake Seismic Risk Assessment). This potential source zone lies at a minimum distance of



about 200 km and therefore is unlikely to have a significant impact at the site.

2.3.2 Seismic Design Parameters

A seismic hazard assessment for the project site has been completed using both probabilistic and deterministic methods. Seismic ground motion parameters for both the Design Basis Earthquake (DBE) and Maximum Design Earthquake (MDE) have been determined.

The probabilistic analysis was carried out by the Pacific Geoscience Centre based on the method presented by Cornell (1968). The results are tabulated below:

Return Period (Years)	100	200	475	1000
Maximum Ground Acceleration (g)	0.021	0.028	0.037	0.046
Maximum Ground Velocity (m/sec)	0.043	0.056	0.077	0.094

For the deterministic analysis four potential source zones were considered for estimation of the maximum ground acceleration at the site. These source zones are the Northern B.C., Southeastern B.C., Northern Cascades and Cascadia Subduction Zones, described in Section 2.3.1. The results are tabulated below together with the maximum magnitude and minimum epicentral distance for each zone:

Source Zone	Maximum Magnitude	Epicentral Distance (km)	Maximum Acceleration (g)
Northern B.C.	5.0	0	0.13
Southeastern B.C.	6.5	40	0.13
Northern Cascades	7.5	200	0.04
Cascadia Subduction Zone	9.0	450	0.08



The Northern B.C. magnitude 5.0 earthquake corresponds to a worst case event occurring directly beneath the project site with a focal depth of 20 km. Maximum accelerations were calculated using the ground motion attenuation relationship given by Idriss (1993), using the Mean +1 standard error relationship. Based on the above, a Maximum Credible Earthquake (MCE) of $M=6.5$ causing a bedrock acceleration of 0.13 g has been assigned to the site.

Selection of appropriate design earthquakes for the tailings facility are based on criteria given by the Canadian Dam Safety Association's , "Dam Safety Guidelines for Existing Dams". These criteria are given on Table 2.5. A "LOW" consequence category has been assessed for the tailings facility as discussed in Section 6.1.2. For closure and post-closure conditions a conservative "HIGH" consequence category has been adopted for design.

The seismic ground motions adopted and implications for design are summarized below:

- The Design Basis Earthquake (DBE) for operations will be taken as the 1 in 475 year return period event. This corresponds to a maximum firm ground acceleration of 0.037 g and maximum ground velocity of 0.077 m/sec. These parameters will be used for the design of all earthworks structures, including all diversion/water storage dams and ancillary earthworks. These values are also recommended for the design of all site buildings and structures, consistent with the National Building Code of Canada. The above ground motion parameters place the site in seismic zone 0 for acceleration and zone 1 for velocity, ($Z_a < Z_v$).
- The Maximum Design Earthquake (MDE) for closure of the tailings facility shall conservatively be taken as 50% of the MCE. This MDE corresponds to approximately the 1 in 2500 year return period event, based on extrapolation of data from the probabilistic analysis. This event gives a maximum firm ground acceleration of 0.065 g



and has been adopted for the design of the embankment for post-closure conditions.

Due to the dense nature of the overconsolidated foundation soils at the project site, the amplification of seismic waves as they propagate from bedrock to the ground surface will not be significant. Case studies have shown that ground motion amplification is negligible through dense soil deposits overlying bedrock. Therefore, maximum bedrock ground motion parameters have been used for design.



SECTION 3.0 - TAILINGS CHARACTERISTICS

3.1 PROCESS DESCRIPTION

The tailings from the Mt. Polley operation will be produced from conventional milling of copper and gold ore. The anticipated tailings stream from the mill to the tailings storage facility will be as follows:

- Solids throughput: 5 million tonnes per year
- Percent solids: 35 percent
- Solids specific gravity: 2.78

The tailings slurry will be deposited from a series of spigots situated along the crest of the embankment. The coarser fraction is expected to settle more rapidly to form sandy beaches with an average slope of about 1 percent. Finer tailings particles will be transported further before settling, with an overall slope of about 0.25 percent expected. Overall, the tailings solids are expected to have an average slope of about 0.5 percent.

3.2 PHYSICAL CHARACTERISTICS

Prior to the 1990 "Report on Geotechnical Investigations and Design of Open Pit, Waste Dumps and Tailings Storage Facility" Coastech Research Inc. conducted preliminary metallurgical testwork on samples of drill core. Tailings samples were obtained from this work and a laboratory testing program was conducted on these samples. Detailed results of the testwork conducted on the tailings for the 1990 report are included in Appendix C and selected information is summarized below.

The tailings are comprised predominantly of silt (64 percent) and fine sand (30 percent) with a trace of clay (6 percent). It is non-plastic, yellow grey in colour and has a solids specific gravity of 2.78.

A series of settling tests were completed at slurry solids contents ranging from 25 to 45 percent. The tailings particles settled rapidly and a pronounced segregation of

describe



coarse to fine material was observed. The colloidal clay fraction remained suspended in the supernatant water for several days.

The tailings initially settled to relatively low dry densities generally in the range of 0.9 to 1.1 tonnes/m³. Consolidation caused by evaporative drying resulted in final dry densities of approximately 1.3 tonnes/m³.

|| consolidat.

The volume of initial water recovered from the tailings depends on the initial solids content of the slurry. At 35 percent solids, the initial water recovery was about 64 percent of the total water in the slurry.

The vertical permeability of the settled tailings was found to range between 1.0×10^{-5} and 2.0×10^{-5} cm/s. The horizontal permeability is expected to be significantly greater due to the pronounced segregation of the soil particles. In practice, the permeability of deposited tailings will be reduced due to on-going consolidation.

how much?

Particle settling velocities were measured as part of the hydrometer test on the silt and clay sized fraction. The data, presented in Appendix C, are used for calculating friction losses in slurry pipelines.

3.3 GEOCHEMICAL CHARACTERISTICS

Geochemical testwork on a locked cycle tailings sample, also previously carried out in 1989 by Coastech Research Inc., included the following:

- Determination of net acid generating potential
- Special Waste Test using acetic acid
- ASTM waste extraction test using carbonic acid

Detailed results of the testwork are also included in Appendix C.

The acid base accounting procedures used were based on recommendations by the U.S. Environmental Protection Agency. The method includes an evaluation of the balance between acid producing components (primarily pyrite) and acid consuming



components (carbonates and other rock types with neutralizing capabilities). The results of this testwork are as follows:

Sulphur (percent)	Paste pH	Acid Potential (kgCaCO ₃ /t)	Neutralization Potential (kgCaCO ₃ /t)	Net Neutralization Potential (kgCaCO ₃ /t)
0.02	8.22	0.6	24.6	24.0

These results indicate that the tailings are not acid producing and have a significant net neutralization potential.

A special waste classification test was conducted in accordance with the procedure published by the B.C. Ministry of the Environment, entitled "B.C. Special Waste List". The results of this testwork are also included in Appendix C. The test indicates that the tailings from the locked cycle tests do not exceed the B.C. Waste Management Branch regulations for special wastes.

In addition to the special waste test, an ASTM waste extraction test using carbonic acid at pH 5.5 was carried out. The test uses carbonic acid for leaching of the tailings and is a more realistic indication of actual long term water leachable constituents under slightly acidic rainfall. Details of the test are also included in Appendix C. The test showed very low levels of water leachable constituents in the extract, all at concentrations below the lower range concentration for the pollution control objectives for final effluent discharge.



SECTION 4.0 - SITE SELECTION

A selection and evaluation of alternative tailings disposal sites was carried out in 1989 and included a comparative assessment of the following factors:

- Capacity and filling characteristics
- Surface hydrology and downstream water usage
- Hydrogeology and groundwater flows
- Aesthetics and visual impact
- Foundation conditions and construction requirements
- Closure and reclamation requirements
- Capital and operating costs

Three possible tailings disposal sites were identified and designated as Areas A, B and C. The site locations and conceptual layouts are shown on Figure 4.1. A preliminary site investigation program was conducted at each site to evaluate the environmental impacts as well as design and construction constraints. Results of initial site investigations for each site were presented in the 1990 "Report on Geotechnical Investigations and Design of Open Pit, Waste Dumps and Tailings Storage Facility" and are not repeated in this report. The three sites are:

- Area A - A cross-valley impoundment located immediately south-east of Bootjack Lake, in the Bootjack Creek Valley (closest site to open pits and mill site).
- Area B - A sidehill impoundment located between the south ends of Polley Lake and Bootjack Lake, within the upper catchment of the Edney Creek Tributary.
- Area C - A cross-valley impoundment located between the north ends of Polley Lake and Bootjack Lake, just west of the Frypan Lake in the 6 k creek swamp.



The evaluation included environmental, design, operational and economic factors. Area A was judged the least favourable because it would have required two cross-valley embankments near the outlet of Bootjack Lake and would have significantly impacted the Bootjack Creek catchment. Area C, located on a natural divide, would also require a cross-valley impoundment and would have impacted both the Bootjack and Polley Lake catchments. Area B is the selected site because it will provide secure tailings storage that would meet all environmental and closure requirements at the least cost. Further, it would minimize potential impacts to both Polley and Bootjack Lake catchments and would keep mine tailings and any leachate confined to the Edney Creek Tributary watershed.



SECTION 5.0 - GEOTECHNICAL CONDITIONS

5.1 SITE INVESTIGATIONS

Geotechnical site investigation programs were conducted in the tailings storage facility area in 1989 and in 1995. The programs included test pits and drill holes to investigate the geotechnical characteristics and foundation conditions and to evaluate the geologic factors affecting the design of the tailings facility. The geotechnical investigations evaluated the tailings basin and embankment foundations, the tailings and reclaim pipeline route and potential borrow areas. The results of the previous geotechnical programs are presented in the following Knight Piésold Ltd. documents:

- “Report on Geotechnical Investigations and Design of Open Pit, Waste Dumps and Tailings Storage Facility (Ref. No. 1621/1)”, February 19, 1990.
- “Report on 1995 Geotechnical Investigations For Mill Site and Tailings Storage Facility (Ref. No. 1623/1)”, March 14, 1995.

5.2 CONSTRUCTION MATERIALS

5.2.1 General

The predominant construction material will be a well graded glacial till which is abundant in the area. Additional minor quantities of sand and gravel for drains, etc. are required. If local sources of sand and gravel are not identified, the material will be imported to the site.

5.2.2 Laboratory Test Work

Glacial till was sampled throughout the tailings facility in the site investigations. Index testing was performed to characterize the materials,



followed by specialized testing to evaluate the compaction characteristics, as well as permeability and shear strength characteristics of the materials.

Selected samples were submitted for the following Index test work:

- Natural Moisture Content
- Atterberg Limits
- Specific Gravity
- Grain Size Distribution

These laboratory test results are presented in Appendix B and summarized in Table 5.1.

Samples were also selected for additional effective strength, compaction and permeability test work as follows:

- C-U Triaxial Tests
- Modified Proctor Tests
- Falling Head Permeameter Tests

These laboratory test results are presented in Appendix B and are summarized on Table 5.2.

Two representative samples of glacial till (TP95-27 and 37) were selected from test pits located in the Perimeter Embankment foundation footprint and within the tailings basin for Index test work. The tills comprised sand and silt with some gravel and clay, with moisture contents ranging from 11.1 to 18.8 percent. The higher moisture content in TP95-37 may be attributed to the close proximity to fractured bedrock where seeps were identified. The moisture content of the till in TP95-27 is typical of the fine-grained tills encountered in the east ridge potential borrow area. Specific gravity tests on the fine fraction of TP95-27 yielded a result of 2.73.



Laboratory compaction tests performed on the till sample from TP95-27 yielded a Modified Proctor maximum dry density of 2200 kg/m³ at an optimum moisture content of 8.0 percent. The optimum moisture content is approximately 3.1 percent below the natural moisture content of the till. The overall compaction characteristics are very similar to the till encountered in the potential borrow area (TP95-31).

Laboratory derived effective strength parameters were determined on glacial till samples from TP95-27 and 37 using consolidated-undrained (C-U) triaxial test work. The samples were compacted to a minimum 95 percent Modified Proctor maximum dry density at the natural moisture content, and confining pressures of 250 and 750 kPa for TP95-27 and 500 and 1000 kPa for TP95-37 were applied in stages until failure developed. The triaxial test was done on both samples and the results were combined to obtain a more representative result of the shear strength properties of the glacial till. The tests resulted in the following shear strength parameters:

- $\phi' = 35^\circ$
- $c' = 0 \text{ kPa}$

Falling head permeameter test work was performed on sample TP95-27 and yielded a permeability of 4×10^{-8} cm/sec. The permeability was similar to the measured permeabilities on glacial till samples from test pits TP95-31 ($k=6 \times 10^{-8}$ cm/sec) and TPB-13, 14 and 16 ($k=2 \times 10^{-8}$ cm/sec).

One sample of glacial till (TP95-31) was selected from the potential borrow area on the ridge east of the tailings facility for Index test work. The till comprised silty, sandy gravel with trace clay, with a moisture content of 11.0 percent.

Laboratory compaction tests performed on this sample yielded a Modified Proctor maximum dry density of 2200 kg/m³ at an optimum moisture content of 7.6 percent. The optimum moisture content is approximately 3.4 percent below the natural moisture content of the till. The overall



compaction characteristics are very similar to the tills encountered in the Perimeter Embankment foundation (TP95-27) and at the mill site (TP95-7).

5.3 TAILINGS IMPOUNDMENT

The well graded low permeability glacial till extends over most of the tailings basin, except at the lower basin and at the Main Embankment where saturated glacial lacustrine fine sand and silt are exposed at surface. These materials are typically dense to very dense and have been heavily overconsolidated by glaciers.

Laboratory testwork on these sediments is included on Tables 5.1 and 5.2. The testwork included C-U triaxial testwork to develop the following shear strength parameters:

$$\begin{aligned}\phi' &= 33^\circ \\ c' &= 0 \text{ kPa}\end{aligned}$$

These shear strength parameters have been incorporated into the stability assessment described in Section 6.6.

Falling head permeability testwork on compacted samples indicated permeability values of between 3×10^{-7} and 2×10^{-6} cm/s. The stratified nature of the in-situ materials indicates that horizontal permeabilities may be an order of magnitude higher than the laboratory values.

The glaciolacustrine sediments are typically saturated. The water table was encountered at or near the ground surface.

Additional samples of undisturbed glaciolacustrine sediments were collected on May 16, 1995 and further Index testwork is currently being conducted. Two Shelby tube samples obtained from the glaciolacustrine sediments have confirmed that they consist of stiff, overconsolidated materials. Extraction of the samples from the Shelby tubes was difficult due to the very dense nature of the material. In addition, three drillholes required for instrumentation will be logged by and tested by a



Knight Piésold Ltd.

CONSULTING ENGINEERS

geotechnical engineer during the upcoming construction program. Samples will be collected and additional testing will be conducted as necessary on the glaciolacustrine sediments.



SECTION 6.0 - TAILINGS FACILITY DESIGN

6.1 DESIGN CRITERIA

6.1.1 General

The principal objectives for the design of the tailings storage facility are to ensure complete protection of the regional groundwater and surface water flows both during operations and in the long-term, and to achieve effective reclamation at mine closure.

The principal requirements of the design are as follows:

- (i) Permanent, secure and total confinement of all solid waste materials within an engineered disposal facility.
- (ii) Control, collection and removal of free draining liquids from the tailings during operations for recycling as process water to the maximum practical extent.
- (iii) The inclusion of monitoring features for all aspects of the facility to ensure performance goals are achieved.
- (iv) Staged development of the facility to distribute capital expenditure over the life of the project.

6.1.2 Design Basis

The design basis and criteria for the tailings storage facility, including the embankments, surface water diversion system and tailings and reclaim pipework systems are based in part on the review comments by the Ministry of Energy, Mines and Petroleum Resources (MEMPR) and on the appropriate and conservative design parameters from hazard classification, seismic data, hydrological studies and geotechnical site investigations. The



basis and criteria for all aspects of tailings facility design, construction and operations are discussed in the following sections and are listed on Table 6.1. Provisions for tailings facility water management, including surface water diversion, seepage flows and flood control are also included.

A hazard classification for the tailings facility has been assessed to establish design flood and seismic criteria. The hazard classification is based on the Canadian Dam Safety Association's (CDSA) "Dam Safety Guidelines for Existing Dams", which states that "Tailings dams and their appurtenant structures must be protected against the same hazards and to the same extent as embankment dams ...". Details of each consequence category and the corresponding potential consequences of failure are given in Table 6.2.

Accordingly, a "LOW" hazard classification or consequence category has been assessed for the tailings facility. This implies that the consequences of failure consist of a low economic loss and low environmental impact. Seismic design parameters relevant to this category have been used for design of the facility during operations. A Design Basis Earthquake (DBE) corresponding to the 1 in 475 year return period event has been adopted, and corresponds to the National Building Code of Canada standard.

For closure and post-closure conditions a conservative "HIGH" consequence category has been selected for design. Specifically, the embankment has been designed to accommodate a maximum design earthquake (MDE) corresponding to 50% of the maximum credible earthquake (MCE) and has been designed to accommodate the PMF flood event.

6.1.3 Construction Schedule

The Stage Ib embankment and surface runoff diversion ditches must be constructed in the summer of 1995 so that one full year of runoff, including the 1996 freshet, is in the tailings storage facility prior to mill start-up, scheduled for late 1996 or early 1997. The Stage Ib embankment also



provides storage for the first year of tailings deposition. The 1995 Stage Ib construction program will include the following activities:

- Tree clearing in the tailings impoundment.
- Construction of the sediment control pond and decant structure below the Main Embankment. This sediment control berm will form part of the relocated Bootjack-Morehead Connector.
- Stripping and clearing of the Main Embankment footprint and tailings basin to El. 931 metres minimum.
- Installation of groundwater monitoring wells.
- Stockpiling topsoil, as required.
- Excavation of exploration trenches to define the limits of the glaciofluvial sediments in the tailings basin and the Main Embankment foundation.
- Placement of basin groundwater drains in exploration trenches and extension of drains to the Main Embankment seepage collection pond.
- Placement of till liner over glaciofluvial sediments exposed in the tailings basin.
- Construction of the Stage Ib Main Embankment to El. 931 metres, including the toe drain.
- Extension of the Main Embankment toe drain pipework to the seepage collection pond.



- Construction of a seepage collection pond for the Main Embankment.
- Stripping and clearing of the Perimeter Embankment footprint up to El. 931 metres minimum.
- Installation of the Stage Ib Perimeter Embankment toe drain outlet pipework.
- Construction of the Stage Ib Perimeter Embankment and toe drain to El. 931 metres.
- Construction of the Perimeter Embankment seepage collection pond.
- Excavation of the reclaim barge channel from El. 918 to El. 932.
- Construction of surface runoff collection/diversion ditches and flow control structures.

Additional work required in the summer of 1996 prior to mill start-up will include:

- Final installation and commissioning of tailings delivery pipework.
- Installation and commissioning of the reclaim barge, pumps, reclaim pipework, booster pumpstation and spill contingency provisions.
- Completion of access road construction.

An approximate construction schedule for Stage Ib is shown on Figure 6.1.

6.1.4 Site Layout and Operating Strategy

The tailings storage facility incorporates the following features:



- A basin liner comprising natural low permeability glacial till over most of the basin and a constructed glacial till liner at lower elevations where glacio-lacustrine sediments are exposed at surface.
- A partial basin groundwater underdrain and seepage conveyance pipework at the Main Embankment.
- A groundwater monitoring well system for evaluating the seepage quality.
- A zoned Main Embankment to be constructed from low permeability glacial till material excavated from within the tailings basin. Similar glacial till materials will be incorporated in all the main zones of the embankment, but placement and compaction requirements will vary between zones. The Main Embankment will have foundation and toe drains and will be raised during operations by a combination of centreline and modified centreline methods. Drainage water and seepage losses to groundwater will be collected in a seepage collection pond and returned to the tailings impoundment.
- The Perimeter and South Embankments will be incrementally constructed as required by the rising tailings level. A seepage collection pond and two groundwater monitoring wells will be incorporated along the Perimeter Embankment.
- Tailings delivery pipework will be installed from the mill site to the Main and Perimeter Embankments. Tailings will flow by gravity for the entire life of the tailings storage facility. Tailings pipework may be extended to the South Embankment in the later years of operation if required. Pipework will include multiple spigot oftakes to allow control of tailings beach development and the location of the supernatant pond. Spill containment provisions are included along the pipeline and emergency discharge points will be located to



ensure total containment of tailings materials within the impoundment.

- A reclaim barge channel will be excavated. A pump barge and pipework will be installed to pump supernatant water back to the mill for re-use in the process plant. The reclaim pipeline also includes provisions for spill prevention, containment and control.
- Diversion ditches and runoff collection ditches will be constructed to allow diversion of the required amounts of surface runoff into the tailings storage facility to meet process water quantity requirements. The diversions will have flow control structures to divert excess water from normal runoff and during storm events out of the facility, as and when required.

Details of the tailings storage facility and runoff control ditches are shown on Dwg. Nos. 1625.110 and 1625.114.

6.1.5 Tailings Storage Capacity

The tailings storage facility depth-area-capacity-filling rate relationships are presented on Figure 6.2. The projected filling rate and rate of rise for the tailings are based on a production rate of 13,425 tpd. The curves indicate that after approximately 3 years of operation the tailings surface area is sufficiently large that the on-going rate of rise is less than 2.5 metres per year. Also, by Year 6 of operations the rate of rise remains constant at approximately 2 metres per year.

The tailings facility has been designed to contain 68.6 million tonnes of tailings solids at an average dry density of 1.28 t/m³ (1.1 t/m³ for Year 1, 1.2 t/m³ for Year 2 and 1.3 t/m³ for Years 3 through 14) with a flat tailings surface.



As shown on Figure 6.3, additional storage capacity has also been incorporated into the design for 2 million m³ of process (reclaim) water on top of flat tailings surface.

An emergency storage volume of at least 0.68 million m³ will also be available on the tailings surface, both at start-up and during on-going operations. This storage volume corresponds to the maximum total runoff from a 24 hour PMP event centred on the tailings facility and the catchment area immediately above the facility, assuming complete failure of the diversion ditches and a 95% runoff coefficient. As discussed in Section 2, the volume is derived from a 24 hour PMP value of 203 mm. Figure 6.3 shows that there is a minimum of one metre freeboard available above the PMP runoff volume inside the impoundment for wave runup and emergency flood storage. The 10 day PMP runoff volume is projected to be approximately 1.36 million m³ which can also be completely contained within the impoundment. Therefore adequate storage capacity will always be available within the tailings impoundment for complete containment of the PMP event, and an emergency spillway will not be required during operations.

0.3m depth @ yr 6.

What?

0.7m @ yr 6

6.1.6 Reclaim Water Storage Capacity

As stated in the previous section, the design of the tailings storage facility includes for the provision of 2 million m³ of storage for reclaim water on top of the tailings surface. This water will be required prior to mill start-up and to supply the milling process during the cold winter months when surface runoff is at a minimum. This stored water is the key to the elimination of the requirement for a dam on Polley Lake.

Tailings solids typically form beaches which slope gradually to the supernatant pond. The depth and extent of the process water pond depends on the slope of the tailings surface. Figure 6.4 provides a summary of capacities, pond depths and pond areas for tailings surfaces which have an



overall slope of 0.5 percent at the end of Year 8 and after Year 14 of operations.

The extent and depth of the supernatant pond have also been determined for tailings slopes of 0.25, 0.5 and 1 percent at various times during operations for both 1 and 2 million m³ of water, the expected range of operational conditions. These studies indicate that there will be sufficient flexibility within the operating plan to ensure adequate storage volume on the tailings surface while maintaining exposed beaches adjacent to the embankment for staged expansions. Based on operating experience at other tailings storage facilities, a tailings production rate of approximately 13,425 tpd will provide sufficient coarse tailings for adequate beach development. The tailings consist of approximately 30 percent sand fraction which is comparable to other tailings at existing facilities which have achieved satisfactory beach development.

Summary
of past
experience

Although an average tailings beach slope of 0.5% is assumed, slopes adjacent to the upstream face of the embankment are typically in the range of 1-2 percent. This assists in maintaining the supernatant pond and phreatic surface away from the upstream face of the embankment during periods of high runoff into the facility.

} 7

6.1.7 Staged Development

The tailings embankments have been designed for staged development during operations in order to minimize initial capital expenditures and maintain an inherent flexibility to allow for variations in operation and production throughout the life of the mine.

The initial embankment (Stage Ib) will be constructed to El. 931 metres to provide adequate storage for 1 full year of surface runoff, including the 1996 freshet, which is required for mill start-up, plus tailings storage for the first year of production. These elevations will allow for uncertainties in the



actual start-up date and ensure that adequate freeboard will be maintained throughout the construction program in the following year.

On-going requirements for embankment construction are shown on Figure 6.3 and on Dwg. No. 1625.111. Staged embankment fill quantities are presented on Table 6.3. The Stage Ic embankment raise by centreline expansion, will provide incremental storage capacity for approximately 1 year of production. The Stage II raise and each of the successive raises will provide incremental storage capacity for approximately 2 years of operation. However, on-going evaluation during operations will provide the basis for determining whether annual raises are more expedient for staged expansion of the facility.

All raises after Stage Ib will require fill to be placed on competent tailings beaches. A coarse bearing layer of gravely alluvium or hard waste rock will be included as required for the initial construction on the tailings beach for Stages Ic and II. The low rate of rise of the tailings surface and the provision of underdrainage at the upstream toe of the embankment will aid in ensuring that the tailings beach is drained and consolidated in order to enhance fill placement on the tailings.

It is anticipated that on-going raises of the tailings embankments will be facilitated by production of cycloned sand from the bulk tailings in the later years of operation.

Additional expansion of the facility is possible to accommodate tailings production in excess of 69 million tons due to increased ore reserves. Embankment raises above the proposed final crest elevation of 960 m would be constructed as required by incorporating a downstream extension of the embankment toe. In addition to an increased storage capacity for the facility this would also ensure that embankment stability is maintained. Detailed stability analyses would be performed in the design of future embankment raises.

/// —
Require how
to below 960
by whom



6.2 TAILINGS IMPOUNDMENT PREPARATION

6.2.1 Clearing and Topsoil Stockpiling

Preparation of the Stage Ib tailings basin and embankment footprints will comprise clearing, stripping and topsoil stockpiling. Tree clearing will also be required over areas of the tailings basin, seepage collection ponds and access roads, during Stage Ib construction. Topsoil will be stripped from the Main Embankment footprint and from the tailings basin up to a minimum elevation of 931 metres, as shown on Dwg. No. 1625.102. The excavated topsoil will be stockpiled in locations shown on Dwg. No. 1625.102 or as otherwise required by the Engineer.

101

6.2.2 Liner Design and Extent

Most of the tailings basin is blanketed by naturally occurring low permeability glacial till which will function as an in-situ soil liner over much of the tailings storage facility. However, near the Main Embankment foundation an imported soil liner will be placed over the glaciofluvial/glaciolacustrine sediments identified in recent site investigations. The extent of the basin liner will be determined by excavating a series of exploration trenches to evaluate both the thickness and quality of the in-situ till soil liner. The anticipated locations of the exploration trenches and the approximate extent of the till liner are shown on Dwg. No. 1625.101, although the final extent will be determined in the field, based on findings of the exploration trenches. The exploration trenches will also be used for the basin groundwater monitoring drainage system. The location of the exploration trenches and basin groundwater drains will be adjusted in the field to promote drainage in surficial materials.

Excavate?

Drains will be included to provide drainage and seepage control in the glaciofluvial/glaciolacustrine deposits in the lower basin and in the Main Embankment foundation, as shown on Dwg. Nos. 1625.101 and 1625.102. The drains will consist of perforated CPT pipes surrounded by drain gravel



and backfilled with suitable free draining material. Geotextile will be used for material separation and filtration surrounding the drain gravel. Drain sections and details are shown on Dwg. No. 1625.102.

*specs??
will it work.*

The imported low permeability basin soil liner will be extended to overlap onto existing dense low permeability till which is at least 2 meters thick or as otherwise required by the Engineer. The liner will be placed and compacted in three 150 mm thick lifts and will then be covered with a 650 mm thick layer of random fill which will serve to protect the liner from frost penetration and equipment traffic. The depth of frost penetration for the first winter has been calculated using methods outlined by Zarling (1990). The following assumptions have been made:

*backfill
that pits.*

specify

- Temperature data from the Likely, B.C. Weather Station.
- Material thermally equivalent to silty sand and gravel.
- Moisture content of fill is 8% and dry density is 1920 kg/m³ (moderately compacted frost protection layer).
- 0.3 m thick layer of snow cover, and no ponded water.

With these assumptions, the depth of frost penetration has been calculated to be 0.4 m during the first winter following construction. However, the protective layer thickness will be 0.65 m to ensure adequate cover in the event of less snow cover and to ensure that the compacted basin liner is not damaged by frost. Details of the liner are included on Dwg. No. 1625.102.

The Engineer will specify the location and frequency of laboratory and in-situ testing of both the natural stripped glacial till materials and of the compacted basin liner prior to placement of the random fill protective layer. The testing program will include field air entry permeameter testing to determine the in-situ permeability of the basin liner. Laboratory permeameter testwork will also be conducted to provide additional quality assurance and quality control information. These procedures will form part of the overall QA/QC program as discussed in Section 6.4.



A groundwater monitoring well system will be installed as part of the 1995 Stage Ib construction program. The wells will be used for groundwater level and quality monitoring and will have the capability to function as pumpback wells.

Location

6.2.3 Sediment Control Structures

In order to prevent turbid surface runoff from impacting the environment downstream of the tailings storage facility, appropriate measures will be taken that will enable the runoff to be controlled and sediments removed prior to discharge into natural water courses, as shown on Dwg. Nos. 1625.112 and 1625.113. The measures will include the construction of a sediment control berm, which will be required prior to basin stripping. Once some embankment fill has been placed the primary sediment control feature will be the tailings embankment.

The criteria which have been used in the design of the sediment control berm include:

- 1 in 10 year 24 hour rainfall with a 100% runoff coefficient (1.35 mm/hr)
- The catchment area is 340 ha, including the entire tailings storage facility (230 ha) plus the immediate catchment above (110 ha).
- The total runoff volume is 110,160 m³

The strategy for sediment control includes the provision of storage capacity for the entire storm volume (above), with a decant structure used to release acceptable water after a suitable retention time. The sediment pond has a storage capacity of 118,300 m³ and has a decant structure which will be used to control the water level. The sediment control berm will also serve as a permanent road fill for the Bootjack/Morehead Connector relocation.



6.3 EMBANKMENT CONSTRUCTION

6.3.1 General

The tailings embankments have been designed for staged development during operations in order to minimize initial capital expenditures and maintain an inherent flexibility to allow for variations in operation and production throughout the life of the mine. The embankment includes three components which are:

- Main Embankment
- Perimeter Embankment
- South Embankment

The Main and Perimeter Embankments are zoned earthfill structures with low permeability glacial till core zones, upstream drains and a downstream random fill zone. The South Embankment is a zoned earthfill water retaining structure. *H.*

The low permeability glacial till liner which will be placed in the tailings basin will also tie into the embankment core zone. The embankments will be expanded using downstream and centreline construction techniques during the first two years. The Main and Perimeter embankments will be expanded by modified centreline methods for the future stages, whereas the South Embankment will be constructed by downstream and centreline methods.

6.3.2 Geotechnical Considerations

The primary geotechnical considerations for embankment construction are foundation stability and drainage. Previous geotechnical investigations at the Main Embankment footprint identified glacial till which overlies the glaciofluvial/glaciolacustrine deposits. Laboratory test work conducted on samples of these materials indicated that both materials have adequate shear *& piping control.*



strength to ensure foundation stability of the embankments. These materials are saturated in the valley bottom and initial construction of the Main Embankment will require the removal of any soft materials prior to the placement of embankment fill. As discussed in Section 6.2, a drainage system will be installed in the Main Embankment foundation and within the lower portion of the tailings basin to allow drainage of the glaciofluvial deposits to facilitate construction and increase the embankment foundation stability. In addition, a low permeability glacial till soil liner will be used to provide a barrier against seepage from the tailings mass in areas where the existing glacial till cover is thin. This liner will tie into both the core of the Main Embankment and the existing thicker deposits of glacial till to provide the tailings basin with a continuous, low permeability liner.

The foundation for the Main Embankment will be prepared to ensure a firm, stable base for the embankment. After topsoil stripping has been completed and prior to commencing fill placement, the embankment footprint will be inspected by the Engineer. Any wet, soft or otherwise unsuitable areas will be excavated and repaired with suitable compacted replacement materials.

As noted in Section 5.2, the glacial till in the proposed borrow areas is found approximately 3% wet of the Modified Proctor optimum moisture content. Achievement of the specified 95% of Modified Proctor maximum dry density and maintenance of a trafficable fill surface will therefore require some drying of the material for use in embankment zone S fill construction. The Engineer will designate the required range of fill placement moisture contents based on results of control tests on samples of the materials from the borrow area.

Adjustment of moisture content will preferentially be carried out in the borrow area by scarifying the surface of the borrow face and allowing the material exposed on surface to dry. The borrow will be developed by scrapers working from one side to the other to selectively obtain drier material. The Contractor will have a disc harrow or Rome plow available to further dry the material on the fill if required by the Engineer. Fill



*check fact
grid
scraper.*

placement will be suspended during rainy periods and all borrow areas and embankment fill will be sealed with a smooth drum roller. Fill and excavation surfaces will also be sloped to promote surface runoff and prevent ponding.

Routine monitoring of piezometers to be installed within the stage Ib embankment will be carried out to ensure that pore pressures do not exceed designated maximum levels required to maintain embankment stability and an adequate factor of safety. Analyses to determine the effect of potential excess pore pressure development on embankment stability during construction are described in Section 6.7.3.

6.3.3 Borrow Areas

The Main, Perimeter and South Embankments will be constructed predominantly from glacial till borrowed from within the tailings basin to the maximum extent possible to minimize ground disturbance outside of the facility and to maximize storage within the impoundment. Borrow areas for on-going staged expansions of the embankments will utilize glacial till borrow materials as indicated on Figure 6.5.

The borrow areas will be selectively developed from the lower elevations within the tailings basin first, in order to provide the maximum amount of borrow from within the basin for on-going staged expansion of the embankment. It is expected that the tailings basin borrow areas will be developed with scrapers and maximum 3h:1v slopes will be specified. Any seams of coarser till or sandy zones will be mapped by the Engineer and compacted low permeability glacial till liner will be constructed over these higher permeability sections after the borrow area is depleted and prior to impoundment of water or tailings.

Construction materials for on-going staged expansion of the tailings impoundment will be obtained from within the tailings basin for as long as practical. However, on-going tailings deposition and project infrastructure



such as diversion ditches, tailings pipework, reclaim pipework and topsoil stockpiles will restrict borrow area development within the tailings basin. Therefore, a separate borrow area immediately downstream of the left abutment of the Main Embankment will be developed as required. This external borrow area has adequate quantities of suitable glacial till materials for on-going staged expansion of the impoundment. The sediment control measures incorporated along the realigned section of the Bootjack-Morehead Connector will remain in place for on-going borrow area development.

6.3.4 Stage Ib Construction

The Stage Ib embankments will be constructed to minimum El. 931 metres in 1995, as shown on Dwg. No. 1625.110. Stage Ib will function as a water retaining dam and will store the freshet runoff as a source of water for mill start-up in the first year. It will also provide storage for the first year of tailings production. The embankments will include a large upstream core zone (Zone S) comprising well graded, low permeability, glacial till placed, disced as required and compacted with a 10 tonne vibratory padfoot roller in 300 mm horizontal layers. The core zone material will be compacted to at least 95% of the modified proctor dry density or as otherwise required by the Engineer. Zone B, situated immediately downstream of the Zone S core will also comprise glacial till materials from local borrow areas. The Zone B glacial till will be placed and compacted by the 10 tonne vibratory padfoot roller in 600 mm layers as required by the Engineer.

rough surface

X
*why vibratory?
in low k?*

The glacial till materials are expected to be slightly wet of the modified proctor optimum moisture content (+2 to +3%) and no special moisture conditioning measures are likely to be required by the Engineer except for discing and drying to reduce the moisture content and selective preparation and drying of the borrow areas if the materials are too wet to ensure proper compaction. In general, the glacial till materials are expected to be suitable for direct placement and compaction in the embankment fill zones.



A toe drain will be installed along the upstream face of the Stage Ib crest to depress the phreatic surface in the tailings and thus minimize seepage through the embankment. The drain will extend to the abutments where pipeworks will extend to the drain monitoring sump. A drainage system will be constructed along the upstream face of the embankment raise to tie into the toe drain and provide drainage and control of the phreatic surface along the length of the embankment.

The Main Embankment seepage collection pond will be constructed downstream of the Main Embankment during the early stages of construction. The pond will collect water from the basin groundwater drains, embankment foundation drains, the groundwater monitoring well system and process water from the embankment toe drain. The solutions will be recycled back into the tailings facility. Details of the Main Embankment seepage collection pond are shown on Dwg. No. 1625.113.

cut off

The first stage of the Perimeter Embankment will also be constructed during Stage Ib, as shown on Dwg. No. 1625.110. Due to the elevation of the ground at the embankment site, only a small section of the embankment is required. A toe drain conveyance of pipe will be installed in the foundation and will drain into the Perimeter Embankment Seepage collection pond, which will also be constructed in 1995. Details of the Perimeter Embankment Seepage collection pond are also shown on Dwg. No. 1625.113. The toe drain will be progressively extended along the abutments during future embankment raises.

The South Embankment is not required until Stage III (Year 2000).

6.3.5 Embankment Drainage Provisions

In order to facilitate drainage of the tailings mass and to control the phreatic surface within the embankment, the following embankment drainage provisions have been incorporated:



- Foundation Drains

A total of four foundation drains have been incorporated in the design, as shown on Drawing No. 1625.102. The drains consist of perforated CPT tubing which run along the axis of the Main Embankment. The CPT tubes are placed in a gravel surround with filter fabric and drain into solid conveyance pipework which runs to the drain monitoring sump. For Stage 1b, two of the drains will be constructed. The remaining drains will be built in future embankment raises. 2??

- Toe and Blanket Drains

An upstream blanket drain will extend along the full length of the embankment in the Stage Ic and II expansions. On-going embankment expansions will incorporate more permeable cycloned sand instead of glacial till for the upstream fill, and the drainage blanket will be replaced by a series of toe drains vertically connected by riser pipes at 50 m centres. 7

Toe drains will be constructed at the Main and Perimeter Embankments and will run the full length of each embankment. The toe drains will consist of perforated CPT tubing with a filter sand surround. The perforated CPT pipes will be connected to solid conveyance pipework which runs to the drain monitoring sump of the Main Embankment. At the Perimeter Embankment, the conveyance pipe will flow directly into the seepage collection pond. The drains will be constructed so that future extensions are easily constructed in subsequent embankment raises.

For Stage 1b, the Main Embankment toe drain slopes from the centre to each abutment, when the pipes will be left exposed for future expansions. The filter sand will be placed all the way up to the Stage 1b crest, as shown on Drawing No. 1625.111. At the



Perimeter Embankment, the toe drain slopes from the abutments to the centre.

6.3.6 Staged Expansions

The staged embankment construction sequence is shown on Dwg. No. 1625.111. The staged expansions will incorporate a combination of centreline and modified centreline construction methods and will utilize glacial till, cycloned sand and random fill for the various embankment zones. The random fill zones will likely be constructed from glacial till from local borrow areas, placed and compacted in 600 mm lifts. However, the specific requirements will be determined after construction and operation of the first phase of the project. The on-going embankment raises will be re-evaluated during mine operations to ensure that adequate storage capacity and embankment freeboard are maintained throughout the life of the mine.

The embankment drains will also be extended during on-going embankment expansions. The Stage Ic expansion of the embankment will include extension of the blanket drain and riser pipes. Some of the subsequent stages will include placement of an additional horizontal toe drain with a perforated pipe that ties into the riser pipework. In general, every second embankment raise will include the installation of a new toe drain. Additional outlet pipeworks to the seepage collection ponds will be included as required based on operational monitoring. These additional toe drain sections and extensions of the pipework will ensure that the drains remain functional during operations and after closure even if minor embankment settlements due to tailings consolidation or earthquake induced deformation occur.

Must be checked

The design will be reviewed on an on-going basis and modifications to drainage systems incorporated as required based on operating experience and monitoring records.



6.4 QA/QC PROCEDURES

The quality assurance (QA) and quality control (QC) procedures are described in detail in the Site Inspection Manual (Knight Piésold 1995, Ref. No. 1625/2). QA/QC testing will be directed by Knight Piésold. A field laboratory will be set up to enable the following control and record testing to be conducted on-site:

- Moisture Content (ASTM D2216).
- Particle Size Distribution (ASTM D422).
- Laboratory Compaction or Moisture-Density Relationship (ASTM D1557)
- Specific Gravity (ASTM D854).
- Atterberg Limits(ASTM D4318).
- Field Density (ASTM D2167).
- Laboratory and Field Air Entry Permeameter(LAEP or FAEP).

Detailed testing frequencies and schedules are outlined in the SI manual and Knight Piésold will provide on-going review of all QA/QC data.

Technical Specifications (Knight Piésold, 1995. Ref. No. 1625/3) have also been developed for the work, including the following:

- Specifications for basin clearing, stripping and topsoil stockpiling.
- Specifications for installation of groundwater monitoring wells, including materials and procedures.
- On-site evaluation of the required extent of the basin groundwater drains and their installation, including materials and procedures.
- Soil liner acceptance or rejection and selection of suitable material for unacceptable subgrade. In-situ soil liner limits and borrow materials will be based on control tests including particle size analysis, permeability (Field AEP), field density and moisture-density relationship.



- Specifications for embankment fill placement, including setting out and grade control (survey) requirements, control and record testing schedule, fill acceptance criteria (as above), equipment requirements, geotextile selection (as needed), compaction specifications, etc.
- Specifications for supply and installation of geotechnical instrumentation including vibrating wire piezometers, read out equipment and monitoring huts, survey monuments, flow monitoring equipment, etc.

6.5 TAILINGS CONSOLIDATION ANALYSES

6.5.1 General

On-going consolidation of the tailings deposit is an important consideration for the design and construction of the facility during operations and at closure. Consolidation occurs continuously within the tailings deposit during deposition, and will continue after completion of operations until all excess pore pressures have dissipated. Expulsion of pore fluids during consolidation produces settlement of the tailings surface and a corresponding increase in the average density of the deposit.

Knight Piésold Ltd. have developed a one-dimensional finite element computer model which predicts the magnitude and rate of tailings settlement, and the corresponding average density of the deposit. This model incorporates variable coefficients of consolidation, a void ratio versus effective stress relationship, an actual or predicted tailings deposition rate and large strain consolidation theory.

Analyses have been performed to predict tailings surface settlements and average densities during operation and at closure.



6.5.2 Parameters and Assumptions

The following parameters and assumptions were incorporated into the consolidation model:

- Void ratio versus effective stress and coefficient of consolidation versus effective stress relationships were based on available data for similar tailings materials which exhibit similar settling characteristics to the Mt. Polley tailings. The selected parameters are felt to be representative of tailings materials which comprise approximately 20-30% fine sand, 70-80% fines and have a specific gravity of about 2.75.
- An initial settled dry density of 1.0 tonne/m³ was used based on the results of laboratory settling tests for a Mt. Polley tailings slurry of approximately 35% solids content.
- A daily production rate of 13,425 tonnes of dry tailings was assumed until closure. Tailings deposition was assumed to be carried out continuously over a 14 year operating period.
- The tailings are assumed to be deposited in horizontal layers across the entire tailings impoundment
- An impermeable (no flow) boundary condition was modelled at the base of the tailings due to the presence of the underlying low permeability till foundation and liner material.
- Evaporative losses from the exposed tailings surface are ignored. Surface desiccation of the tailings will further assist in consolidation and densification of the deposit, particularly after closure once tailings deposition has ceased and the supernatant pond has been removed.



6.5.3 Results

Estimates of tailings surface elevation and average dry density with time have been computed for a 14 year operating period.

An average dry density of approximately 1.1 tonne/m³ was predicted after the first year of operation, and approaches a value of 1.2 tonne/m³ after 2 years. Thereafter, the average dry density increases to about 1.3 tonne/m³ and is maintained until closure. The density of the deposit will increase more rapidly once tailings deposition ceases at closure and self weight consolidation continues, assisted by surface desiccation due to evaporation.

The tailings deposit will remain partially consolidated during operations and for a period of time after closure until all excess pore water pressures have dissipated. The actual time taken for complete consolidation will be dependent on the in-situ consolidation characteristics of the tailings material.

6.6 EMBANKMENT SETTLEMENT

6.6.1 General

Settlement of the embankment fill material occurs progressively as the embankment raises extend over tailings beach material. Analyses have been carried out to predict the magnitude of these settlements using the one-dimensional finite element computer model described in Section 6.5.1. In addition to on-going deposition and consolidation of the tailings material, surcharge loading has been applied to represent construction of overlying embankment raises.

Three tailings columns were examined at increasing distance from the Stage Ib crest as shown on Figure 6.6 and summarized as follows:



Column A - 6 metres of tailings overlain by embankment Stages II to VII.

Column B - 19 metres of tailings overlain by embankment Stages IV to VII.

Column C - 30 metres of tailings overlain by embankment Stages VI and VII.

Void ratio versus effective stress and coefficient of consolidation versus effective stress relationships for the tailings beach material were based on data obtained for similar coarse tailings material from existing tailings facilities. An initial settled dry density of 1.2 tonne/m³ was adopted for the beach tailings which will consolidate more rapidly than the tailings slimes within the facility.

Analyses have been carried out to predict embankment settlements after each on-going staged expansion.

During the initial year of operation tailings will be discharged into stored make-up water within the facility. Lateral segregation of tailings and beach development will be limited during this time and tailings deposited adjacent to the embankment will consist of a mixture of bulk tailings material. This material will likely not consolidate as rapidly as the coarser beach tailings. The average degree of consolidation of this initial "bulk" tailings zone has been predicted. Consolidation parameters used for the tailings consolidation analyses described in section 6.5 were adopted to represent these tailings and are likely to be conservative.

6.6.2 Results

Estimates of embankment settlements have been made due to staged expansions up to the final Stage VII crest elevation of 960 m. These represent the maximum settlements at the deepest section of the embankment.



The "bulk" tailings adjacent to the Ib embankment crest are approximately 50% consolidated prior to construction of the Stage Ic raise. Settlement of about 0.3 m was predicted during construction of the Stage Ic embankment raise onto this material. This settlement will be compensated for during initial placement of the coarse bearing layer on the tailings and during fill placement. Consolidation occurs rapidly during fill placement and underlying tailings were predicted to be over 90% consolidated immediately after construction. This material does not have a significant effect on predicted embankment settlements. The compressibility of this material is likely to be higher than the coarser beach tailings only at low effective stresses. Due to confinement imposed by additional tailings deposition, effective stresses will increase in this underlying material. Therefore, the compressibility of these tailings will be similar to the overlying beach tailings by the time on-going embankment raises are constructed.

The majority of settlement for each of Columns A, B and C occurs during placement of embankment fill, due to consolidation of partially consolidated tailings material near surface. Placement of a coarse bearing layer where necessary and fill placement during construction routinely compensates for these initial tailings settlements. Excess pore pressures generated in the tailings during fill placement dissipate rapidly and the degree of consolidation is typically 80 to 90% by the end of construction of each raise.

Embankment settlements in Column A after construction of each raise were predicted to be negligible, with consolidation of the underlying tailings being complete shortly after construction of each raise. Settlements for Columns B and C were also minor with maximum values of 0.2 metres in Column B and 0.35 m in Column C after construction of Stages IV and VI respectively. Further settlement due to additional embankment raises are even smaller as the tailings become less compressible at the high confining pressures imposed by overlying fill. Settlements will also vary laterally along the embankment crest due to the variable thickness of underlying tailings. The minor settlements given above correspond to maximum values



in the deepest section of the facility and therefore differential settlements will not be significant.

For these analyses, only the toe drain located at the Stage Ib crest was assumed to assist in drainage and the dissipation of excess pore pressures in the tailings. Additional toe drains will be provided at every second embankment raise allowing increased consolidation in the tailings mass. Therefore, settlements are likely to be even smaller than those predicted above.

On-going fill placement during staged expansion of the embankment routinely compensates for settlement of the embankment crest. Sloping internal embankment zones and the chimney drain will deform slightly but will result in only a very slight flattening of the embankment drainage system. This will not reduce the efficiency or integrity of the system.

6.7 STABILITY ANALYSES

6.7.1 General

Embankment stability analyses were carried out using the limit equilibrium computer program SLOPE/W. In this program a systematic search is performed to obtain the minimum factor of safety from a number of potential slip surfaces. Factors of safety have been computed using Bishop's Simplified Method of Slices.

Analyses have been performed to investigate the downstream stability of the embankment under both static and seismic conditions. These comprised checking the stability of the final embankment arrangement for each of the following cases:

1. Static conditions during operations, closure and post-closure.



2. Earthquake (pseudostatic) loading during operations, closure and post-closure.
3. Residual (post-liquefaction) tailings strength conditions.

For conditions during operations and at closure the tailings were assumed to be only partially consolidated, based on the results of the consolidation analysis. Therefore, an appropriate undrained shear strength was assigned to the tailings. Tailings effective strength parameters were used for the long term post-closure condition when complete consolidation has been achieved.

Tailings beach development and the embankment drainage system have been designed to maintain the phreatic surface away from the upstream face of the embankment. However, the conservative case of a phreatic surface within the embankment core zone was also examined as a worst case condition.

The upstream stability of the embankment has also been considered for the Stage Ib embankment during water storage conditions and at closure for the final embankment configuration.

Minimum acceptable factors of safety of 1.3 and 1.5 have been adopted for this design for static conditions during operations and at closure respectively. A minimum acceptable factor of safety of 1.1 is considered appropriate for the tailings residual strength condition.

Check?

The stability of the embankment under earthquake loading was analyzed by applying a horizontal seismic coefficient (acceleration) to the potential sliding mass. Factors of safety greater than 1.0 imply that there will be no deformations of the embankment initiated by earthquake loading. For conditions during operations the Design Basis Earthquake was used, as determined by the hazard classification for the tailings facility. The Maximum Design Earthquake was used for closure and post-closure conditions.



The influence of construction pore pressures on embankment stability has also been considered.

6.7.2 Material Parameters and Assumptions

The following parameters and assumptions were incorporated into the stability analyses:

- Bulk unit weights for the embankment and foundation materials are based on testwork performed on representative samples. This testwork was carried out as part of the 1995 geotechnical investigations (Report 1623/1, March 1995). An average bulk unit weight for the tailings deposit adjacent to the embankment was estimated from the results of the consolidation analysis. The cycloned sands (Zone CS) were assigned a typical value for this material.
- Partially consolidated tailings during operations and at closure were assigned typical undrained shear strengths ranging from 10 kPa to 55 kPa at depth. For fully consolidated tailings an average effective friction angle of 30° was adopted. These are lower bound strengths obtained for other similar tailings materials from in-situ Shear Vane and Cone Penetration Testing.
- Effective strength parameters for the embankment fill and foundation materials were obtained from consolidated-undrained triaxial testwork performed on representative samples. These samples were obtained during the 1995 geotechnical investigation (Report 1623/1).
- An effective friction angle of 32° was adopted for the cycloned sands (Zone CS), which is considered conservative for this material.



- An undrained shear strength of 10 kPa was adopted to represent the residual (steady state) strength of the tailings material. This is based on lower bound values obtained for similar tailings materials and is also consistent with lower bound data presented by Seed (1990) for the residual undrained shear strength of sands.
- The location of the phreatic surface within the tailings facility has been estimated from a steady-state seepage analysis, details of which are given in Section 7.

reference

The geometry, material parameters and location of the phreatic surface adopted in the stability analyses are illustrated on Figure 6.7.

6.7.3 Results of Analyses

6.7.3.1 Downstream Stability

For the static case during operations a minimum factor of safety of 1.43 was calculated. This value will increase after closure as tailings consolidation continues with a corresponding gain in strength. Once a minimum factor of safety of 1.5 is obtained it is no longer dependent on tailings strength and the potential slip surface is located within the embankment. The location of potential slip surfaces during operations/closure and post-closure are given on Figures 6.8 and 6.9 respectively.

The factor of safety at closure is dependent on the degree of consolidation and strength of the tailings material adjacent to the embankment. If on-going monitoring records and stability evaluations indicate that the minimum required factors of safety are not achieved, a small stability berm will be constructed at the downstream toe to obtain factors of safety greater than 1.5.

For the extreme case of a phreatic surface within the embankment core zone a factor of safety of 1.37 is calculated for the embankment at closure. If on-



going monitoring and piezometric records indicate that an elevated phreatic surface can develop in the embankment then appropriate stabilization measures will be incorporated to ensure a minimum factor of safety of 1.5 after closure.

Subs

For earthquake (pseudostatic) loading during operations a minimum factor of safety of 1.28 was computed for a seismic coefficient of 0.04, corresponding to the Design Basis Earthquake. For conditions at closure and a seismic coefficient of 0.065, representing the Maximum Design Earthquake, a factor of safety of 1.2 was obtained. The location of the potential slip surface for each case are shown on Figures 6.10 and 6.11. It should be noted that even for a seismic coefficient of 0.13, representing the Maximum Credible Earthquake, a minimum factor of safety of slightly above 1.0 is maintained.

Good!

The tailings residual strength case represents the steady state strength of the material after degradation by in-situ straining. Such a condition can occur if liquefaction is initiated in the material by rapid static or seismic loading which causes a corresponding increase in pore pressures. A factor of safety of 1.39 was calculated for this case. This indicates that the embankment is not dependent on tailings strength to maintain overall stability. The potential slip surface for this case is shown on Figure 6.12.

It is recognized that some variability in material strength is possible for the embankment fill and foundations soils. A sensitivity analysis has been performed to determine the variation in computed minimum factors of safety for varying effective friction angles in these materials. Both downstream static stability during operations and post-closure pseudostatic loading have been considered. The results of these analyses are shown on Figure 6.13. It is clear from this figure that a reduction in effective friction angle of several degrees is possible while still maintaining factors of safety of greater than 1.3 and 1.0 for the static and pseudostatic cases respectively.



6.7.3.2 Upstream Stability

The minimum upstream static factor of safety for the Stage Ib embankment during water storage is 1.56 and will increase once tailings deposition commences. Under seismic loading conditions for the Design Basis Earthquake a minimum factor of safety of 1.37 was computed. The probability of occurrence of such an event during Stage Ib construction and water storage is extremely low. However, even for these worst case conditions a factor of safety well above the minimum of 1.0 is maintained.

For the final embankment configuration the most critical condition occurs immediately after construction of the Stage VII raise. The factor of safety for this condition is 1.37. This value will increase rapidly as the tailings surface adjacent to the upstream face rises during on-going deposition, thus buttressing the slope, and a value of 1.53 has been calculated for the final tailings surface elevation. The minimum factor of safety under seismic loading from the DBE is 1.26.

An average effective friction angle of 30° was adopted to represent the beach tailings adjacent to the upstream embankment face. These coarser more free draining, tailings will consolidate rapidly. Consolidation modelling has shown that these tailings achieve complete consolidation shortly after placement of the embankment raise. The location of potential slip surfaces and assumed phreatic surfaces for each case are shown on Figure 6.14.

6.7.3.3 Construction Pore Pressures

The influence of the construction pore pressures on the stability of the Stage Ib embankment has also been considered. This starter embankment will be constructed to a height of 18 metres during approximately a 3 month period and represents the largest construction lift for the facility.



To maintain a minimum factor of safety of 1.3 during construction, pore pressures within the embankment fill should not exceed an R_u coefficient of 0.14, where R_u represents the ratio between total stress and pore pressure at any depth. Therefore, the maximum sustained pore pressure reading in the lower fill piezometers must be less than 50 kPa in order to maintain the minimum factor of safety of 1.3 for embankment stability during construction.

Pore pressures will be routinely measured during construction using piezometers installed into the embankment fill and foundations.



SECTION 7.0 - SEEPAGE ANALYSES

7.1 GENERAL

Seepage analyses were performed using the finite element computer program SEEP/W. The purposes of the analyses were:

- To establish the pore water pressures within the embankments for stability analyses.
- To estimate the amount of seepage discharge from the tailings storage facility.

The seepage rates at each of the Main, Perimeter and South embankments were considered. The analyses have been based upon simplified cross sections as shown in Figure 7.1 and the saturated hydraulic conductivities as shown in Table 7.1.

During the initial year of operations tailings will be discharged into stored make up water, resulting in limited beach development. As a conservative approximation fine tailings, (zone 3), have been assumed to extend to the upstream face of the embankment up to the maximum stored make up water elevation of 925 m.

7.2 SUMMARY OF PARAMETERS

Saturated and unsaturated hydraulic conductivities were determined for each material in the embankment and foundation zones. In assigning hydraulic conductivity values for the seepage analysis, the typical conductivity functions of similar soil properties in SEEP/W were used. These functions were slightly adjusted to match with the actual saturated conductivities of the material. Hydraulic conductivity values for the tailings mass, embankment and foundation were determined as follows:



- The tailings mass was sub-divided into three zones with decreasing hydraulic conductivity to more accurately model the consolidated, less permeable tailings with depth.
- Hydraulic conductivity values for the various zones of the embankment and foundation were estimated based upon typical values for similar materials.

7.3 BOUNDARY CONDITIONS AND FLUX SECTIONS

Boundary conditions were imposed on the modelled sections to more accurately represent hydrogeologic conditions in the field. These conditions are summarized as follows:

- A no-flow boundary condition was assigned to the nodes along the left side of the model.
- A total head boundary was imposed at the tailings surface to model a supernatant pond.
- The upstream embankment toe drain was modelled by applying a no-head condition at that location.
- Foundation drains were modelled by applying no head nodes at drain locations.
- A hydrostatic pore pressure profile with the water table 2 metres below the ground surface was assigned to the right boundary of the model.

Flux sections were included in the model to estimate seepage flow across the various geological units, as well as the engineered components. The following locations, in particular, were examined closely:

- Seepage inflow to the upstream toe drain.



- Flow collected by foundation drains.
- The amount of seepage flow which bypasses the seepage collection systems.

The amount of flow collected by the seepage collection systems, i.e. the upstream toe drain and foundation drains will drain to seepage collection ponds downstream of the Main Embankment and Perimeter Embankment. These seepage flows will be recycled to the tailings impoundment. The seepage flows which bypass these seepage collection systems are the only component which will be lost to groundwater.

7.4 RESULTS

A summary of results from the seepage analyses is presented in Table 7.2.

Two cases were analyzed with low and "high" foundation glacial till permeabilities to determine the range of foundation seepage rates. Each case assumed a filled tailings facility with a maximum hydrostatic head in order to determine the maximum seepage rate. For the low permeability case, the foundation glacial till was assigned a permeability of 10^{-7} cm/sec, and a total solution flow rate of 3.8 ℓ/s (51 gpm) was calculated from the tailings mass. Approximately 90% of the flow was collected in the upstream toe and embankment foundation drains, while the remaining 10% of the solution flowed through the foundation. For the high permeability case, the foundation glacial till was assigned a permeability of 10^{-6} cm/sec, and a larger total flow rate of 4.5 ℓ/s (59 gpm) was calculated. In this case, the solution flowing through the foundation increased slightly to 13%.

In the low permeability case, the solution flow contribution made by each of the four components is as follows:

- The upstream toe drain collected 76% (2.9 ℓ/sec or 39 gpm).
- The embankment foundation drainage system collected 13% (0.5 ℓ/s or 7 gpm).



- Seepage loss through the foundation was 11% (0.4 ℓ /sec or 5 gpm).

In the high permeability case, the solution flow contributions are as follows:

- The upstream toe drain collected 71% (3.2 ℓ /sec or 42 gpm).
- The embankment foundation drainage system collected 16% (0.7 ℓ /sec or 9 gpm).
- Seepage loss through the foundation was 13% (0.6 ℓ /sec or 8 gpm).

Considering the results of these two cases, it is evident that the permeability of the foundation glacial till has only a minor effect on the projected seepage flow rate through the foundation for the ultimate impoundment. The seepage rates presented above are expected maximum values which occur late in the project. However, during the early years of operation, seepage rates are expected to be lower, particularly at the Perimeter and South embankments where the natural groundwater table provides complete hydraulic confinement during the first year. As the tailings surface rises, the seepage rate is expected to gradually increase to the maximum values presented above.

Tailings facility construction is scheduled to begin in 1995. In the first year of operation the dam crest elevation will be 931 m, and the facility will be used for storage of water. During this period the seepage flow has been estimated to be 0.22 ℓ /s flowing across the Main Embankment only. Seepage flow development at each of the different embankments have been estimated from the results of the seepage analyses. The variation in seepage flow rates versus year of operation are presented in Figures 7.2 to 7.4.



SECTION 8.0 - WATER BALANCE AND MANAGEMENT

8.1 GENERAL

The water management strategy for the Mount Polley project was recently reviewed and presented in the "Report on Project Water Management" (Ref. No. 1624/1, February 6, 1995), which is included in Appendix A. The tailings impoundment will be utilized as a water reservoir both prior to start-up and during operations, thus eliminating the need for a dam on Polley Lake. The water management plan has the following objectives:

- To minimize the volume of fresh water extracted from Polley Lake.
- To limit the period of water removal from the Polley Lake/Hazeltine Creek system to high flow periods.
- To regulate additional surface water runoff into the tailings pond.
- To prevent the accumulation of excess water within the tailings impoundment so that the impoundment and open pit can be operated as a closed system with no surface water release.
- To supply make-up water for the milling process from within the project catchment area.
- To minimize the requirement for regulated discharges of surface runoff from the waste dumps.

These objectives will be managed simultaneously during operations by provision of surface water collection ditches around the project perimeter and by judicious transfer of "fresh" surface runoff from designated undisturbed catchment areas adjacent to the tailings impoundment. The most recent water management strategy differs slightly from the concept presented in Appendix A (Report on Project Water Management, Ref. No. 1624/1) as Catchment Area A will no longer be utilized as a



source of surface runoff for transfer to the tailings impoundment. Catchment Areas B and C will serve as the main source of additional runoff water which is required after collection of millsite and waste dump runoff.

A schematic of the overall facility and water management components is shown on Figure 8.1.

8.2 WATER BALANCE

8.2.1 General

An overall project water balance was completed by integrating the water balances for the mine site with the those for the tailings storage facility. The analyses included a comprehensive series of water balances to evaluate the volumes of surface runoff water available throughout the life of the mine. Average annual water balance schematics are illustrated on Figures 8.2 and 8.3 for Years 1 and Year 14 respectively.

A probabilistic water balance analysis using the @RISK Analysis and Modelling program was developed to describe the effects of a statistical range of precipitation conditions over the entire life of the project. Over 1000 different combinations of wet and dry precipitation conditions have been conducted. From the corresponding results, estimates were made of the probable requirements for fresh make-up water, probable tailings pond volume and probable volumes of additional water to be diverted out of the project area.

The overall project components include disturbed and undisturbed areas at open pits, waste dumps, mill site, tailings storage facility, and the additional undisturbed catchment areas (Areas A, B and C) immediately upgradient from the tailings area. The water balances considered the staged development of the various components of the project. Specific assumptions incorporated in the water balance analyses are consistent with those used in



previous water balances for the tailings impoundment and mine site conducted in 1991.

8.2.2 Water Balance Results

When conducting the water balances, a fundamental consideration for the supply of process water to the milling circuit is that an adequate volume of water must be available during the cold winter months when precipitation accumulates as snow and surface runoff is at a minimum. Also, a sufficient volume of water is required for mill start-up. Given these critical requirements, water balances were carried out for all 14 years of the project life, under a range of hydrometeorological conditions and for the various catchment areas.

The variation in the volume of the tailings pond for average precipitation conditions exists because it reaches a minimum during the winter months when there is little surface runoff and reaches a maximum volume in the late spring after the freshet.

These water balances, included in Appendix A, indicate that the water requirements for the project can be obtained by:

- Selectively diverting approximately 1.5 million m³ of surface runoff into the tailings impoundment prior to start-up.
- Providing a minimum volume of about 1.5 to 2 million m³ of water in storage on the tailings surface during on-going operations in order to provide sufficient process water during the cold winter months when surface runoff is minimal.
- Allowing for contingency water extraction of about 300,000 m³ annually from Polley Lake or Hazeltine Creek during peak flow months.



The revised water management strategy, wherein a much smaller reservoir of make-up water is maintained on the tailings surface (as compared to the previously proposed Polley Lake live storage) represents a greater risk for the mine operators during periods of extended drought. However, this risk has been minimized by including the contingency extraction provision of 300,000 m³/yr from either Polley Lake or Hazeltine Creek. The likelihood that this volume of water would be required is very low (estimated to be less than 5%). It is proposed that this 300,000 m³ volume will be extracted at a maximum rate of about 150,000 m³/month during the peak flow period at spring freshet so that the impact on the fisheries resource will be minimal.

8.2.3 Water Supply at Start-Up

As stated above, the revised water management plan requires that an estimated minimum volume of 1.5 million m³ of water be stored in the tailings impoundment prior to mill start-up. This water will be obtained by constructing the first stage of the tailings embankment (Stage Ib) at least one year before mill start-up to allow capture of one year of direct surface runoff, including the freshet. The amount of surface runoff which will be collected by the Stage Ib embankment for various precipitation conditions is summarized as follows:

Summary of Water Available at Start-Up	
Precipitation Condition	Surface Runoff Water (m ³) Available From TSF and Catchment Area B
Average Year	1,557,000
10 Year Dry	1,156,000
50 Year Dry	977,000
10 Year Wet	2,025,000

These results indicate that up to 300,000 m³ of water may be required from Polley Lake during peak freshet flows to provide the required 1.5 million m³ of water to be stored prior to start-up if 10 year dry conditions (or dryer)



are encountered in 1996. Therefore, the surface runoff collection ditch has been extended to intercept additional catchment from Area C, immediately adjacent to Catchment Area B.

8.3 WATER MANAGEMENT PLAN

8.3.1 General

The objective of the project Water Management Plan in the early years will be to route all project water flows from disturbed areas into the milling process or into associated mine site activities such as dust suppression. An additional objective is to selectively route runoff from Catchment Areas B and C into the tailings impoundment (Stage Ib embankment) to provide the 1.5 million m³ of water required prior to mill start-up. In the later years of operation the objective will be to monitor and release selected surface water inflows in order to manage the final volume of ponded water in the tailings impoundment at closure. The following activities will be incorporated in the Water Management Plan:

- (i) Maximize the capture of surface and groundwater flows from within the project area.
- (ii) Maximize the use of the poorest quality water recovered from within the project area in the milling process and in associated activities (such as dust suppression).
- (iii) Minimize the deliberate introduction of excess clean fresh water from Polley Lake and Hazeltine Creek.
- (iv) Monitor the quality of surface runoff from disturbed areas and groundwater flows within the project site.
- (v) Release only the best quality water from within the project boundaries and in accordance with permitted requirements, as is



necessary to maintain an overall project water balance under actual hydrometeorological conditions.

- (vi) Manage the operation of the tailings supernatant pond to optimize the volume of water stored on the tailings surface during operations and at closure.
- (vii) Develop and maintain a detailed data base to allow water balances for the site to be as accurate as possible and thereby become useful tools for predicting annual make-up water requirements and for scheduling releases of clean surface runoff water as appropriate.

8.3.2 Surface Runoff Diversion Ditches

The runoff diversion facilities and their catchment areas are shown on Dwg. No. 1625.114. Surface runoff diversion ditches will be provided to allow diversion of surface runoff to the tailings storage facility from various catchments as follows:

- Catchment Areas B and C - A runoff collection ditch and flow control structures will be built along the Bootjack-Morehead Connector Road. Runoff from this area will be diverted at flow rates of up to approximately 2.5 m³/s. Flood flows from extreme precipitation and snowmelt events will be routed offsite through overflow culverts located in existing stream courses.
- Catchment above tailings storage facility - in general, all runoff from this area will be captured in the tailings storage facility during the early years of operation. However, diversion ditches will be included in the Stage Ib construction program to allow active management of this runoff in case of a water surplus in later years of operation.



- Catchment above tailings area access road, below Bootjack Creek - this diversion ditch serves both as a pipeline spill containment ditch and a surface runoff conveyance ditch. All runoff will be directed to the tailings storage facility.
- Catchment above tailings access road, between millsite and Bootjack Creek - the runoff will be returned to Bootjack Creek with no transfer to the tailings storage area.
- Millsite area - diversion ditches along the lower perimeter of the millsite area will collect runoff from the millsite and convey the water to a sediment pond. This water will then be piped back to the mill or to a drop box to the tailings pipeline so that the millsite runoff can be returned to the process circuit via the tailings and reclaim systems.

The design criteria for the diversion ditches are as follows:

- The ditches are sized to convey the peak flow runoff from the 1 in 50 year precipitation event. This flow was determined on the basis of site IDF values and the rational formula, as outlined in the MOE Manual of Operational Hydrology.
- Erosion protection and energy dissipation will be provided to minimize erosion under normal operating conditions. Erosion damage requiring repairs to surface water control facilities would be expected during extreme flood events.
- For design purposes, “extreme” floods are defined as those with an annual probability of occurrence of less than 2%.
- The need for sediment removal at flow control structures and sediment control ponds should be checked annually and after major storm events and carried out when necessary.



The design criteria for the flow control structures at Catchment Areas B and C are as follows:

- All flows less than or equal to 2.5 m³/s can be conveyed to the tailings facility.
- Slide gates are provided to close off the diversion culverts when sufficient water is in storage on the tailings surface.
- The depth discharge curve shown on Dwg. No. 1625.115 was computed based on inlet control to 900 mm diameter culverts.
- Final design of flow control structures will require consideration of detailed geometry and ground conditions at individual existing creek crossings to ensure proper performance.
- A Parshall flume will be provided to monitor inflows to the tailings storage facility from the Area B catchment. Details of the Parshall flume and a depth-discharge curve are shown on Dwg. No. 1625.115.

8.3.3 Sediment Control Ponds and Discharge Requirements

Sediment control ponds which discharge to the environment will be sized to provide a 10 hour retention time of the 1 in 200 year - 24 hour storm runoff flood flows from the tributary catchment above the sediment pond. All sediment ponds will be built with 3:1 internal slopes for easy access for machinery. Erosion control and energy dissipation riprap will be provided as necessary in spillways and discharge channels.



SECTION 9.0 - PIPEWORK

9.1 GENERAL

This section describes the pipework and pump systems required for the tailings and reclaim pipelines and for the seepage recovery system. Design criteria are given for the various components of the pipework associated with the tailings storage facility. The pipeline plan and profiles are shown on Dwg. No. 1625.116. Sections and details are shown on Dwg. No. 1625.117.

9.2 TAILINGS PIPEWORK

9.2.1 General

The tailings pipeline will extend approximately 7000 m from the millsite to the southwest corner of the tailings storage facility. The tailings system is designed to flow by gravity and therefore to be self-draining.

9.2.2 Design Criteria

The tailings pipeline will be designed to the following criteria:

- Millsite tailings discharge at approximately El.1110.
- Tailings embankment crest elevation at startup = El.931.
- Tailings embankment crest elevation at end of mine life = El.960.
- Continuous downhill gradient provided to ensure free draining condition. This prevents potential sanding and freezing problems in the tailings pipeline.
- The pipe size was chosen to allow gravity flow conditions, (e.g. open channel or non-pressure flow) over a wide range of operating



conditions. The hydraulic gradeline and the conditions acting to raise or lower it are given on Dwg. No. 1625.116.

- All pipework is butt fusion welded HDPE.
- A drop box is provided below the millsite to allow addition of millsite runoff from the millsite sump to the tailings stream.
- A drop box is provided along the tailings line to allow addition of waste dump runoff from the south sediment control pond to the tailings stream.
- A drop box is provided at the reclaim booster pump station for reclaim booster sump overflow into the tailings pipeline.
- Spill containment is provided for the full length of all pipelines.
 - ◇ From the millsite to Bootjack Creek the pipelines are buried in compacted select fine grained till below the ditch of the tailings access road, (see Section 1/1625.117).
 - ◇ For the Bootjack Creek crossing the pipelines are sleeved to provide spill containment. The pipe sleeves are closed at the upstream (buried pipeline) end and open at the downstream end to drain to the pipe containment channel (see Section 3/1625.117).
 - ◇ From Bootjack Creek to the tailings storage facility the pipelines are laid in a pipe containment channel cut in (or lined with) glacial till (see Section 4/1625.117).

9.2.3 Tailings Delivery Pipework

The tailings pipeline is designed as 22 inch (558 mm) dia High Density Polyethylene (HDPE). Pipe wall thickness (pressure rating) will be selected



to accommodate anticipated operating pressures and vacuum conditions as well as including an allowance for internal abrasive wear.

9.2.4 Tailings Discharge Pipeline

The tailings pipeline will run along the inside crest of the tailings embankment and will be provided with a series of discharge points to allow controlled deposition of tailings over the tailings beach. To provide operational flexibility and to facilitate pipeline moves during embankment raising, the tailings discharge pipework will be made up in a number of repeating units, each comprised of:

- a flange at the upstream end,
- several tailings discharge points spaced at 20 to 30 m along the pipe and
- in-line valves as appropriate.

The tailings pipeline will be secured on the embankment crest by use of straps and concrete blocks or by guide posts to prevent thermally induced movements of the pipeline.

The discharge spigots will be made from one of a number of commercially available options for this purpose. A typical discharge point or "spigot" comprises:

- a strap-on tee sleeve,
- a pinch valve (required for regulation of high flows or pressures),
- a length of soft PVC (Li-flat type) hose or HDPE pipe

A scissor clamp for on-off control of tailings flow may be substituted for a pinch valve at low pressure sections. Appropriate erosion control measures will also be included at the discharge points.



9.3 RECLAIM WATER SYSTEM

9.3.1 General

The reclaim water system returns water from the tailings storage facility to the raw water tank in the millsite for re-use in the process circuit. The reclaim water system comprises a pump barge, the reclaim pipeline and a reclaim booster pump station.

9.3.2 Design Criteria

The reclaim water system is designed to meet the following criteria:

- Provide adequate pipeline and pumping capacity to meet operational process requirements.
- Stage 1 (start-up) drawdown range of initial pond using the pump barge channel from El.918 to El.932.
- Provide a booster pump station at the midpoint of elevation to:
 - ◇ Reduce pressure rating requirement for pipelines.
 - ◇ Allow use of the same pumps on the barge and in the booster station to reduce spares required and simplify maintenance.

9.3.3 Reclaim Barge

The reclaim barge will be a prefabricated floating pump station complete with perimeter trash screens, internal wet well(s), pump(s), valving, piping, electrical power, instrumentation and control circuitry.

A hinged walkway/pipe bridge is provided for access to the barge from the side of the reclaim barge channel. The reclaim barge channel is shown in



plan on Dwg. No. 1625.116 and in section on Dwg. No. 1625.117 (Section 3).

The reclaim barge will include water jets or an air bubbler system to prevent freezing around the reclaim barge.

9.3.4 Reclaim Pipelines

The reclaim pipelines will extend from the pump barge to the booster pump station and from there to the raw water tank in the millsite. Due to the high pressures involved, the lower sections of both pipelines will be heavier wall and the upper sections will be lighter wall HDPE pipe. Nominal 24 inch (600 mm) diameter pipelines have been selected to provide the required water transfer capacity.

9.3.5 Reclaim Booster Pump Station

The reclaim booster pump station will be a prefabricated unit using identical parts to those at the pump barge to the greatest degree possible for interchangeability and ease of maintenance.

An interlinked control system will co-ordinate pump operations with process water demand at the millsite. The control system and pipeworks design will include necessary provisions for spill prevention.

9.4 SEEPAGE RECOVERY SYSTEM

9.4.1 Monitoring Wells

Three monitoring wells, shown on Dwg. No. 1625.110, will be provided to monitor seepage from the tailings area. These wells will be sampled prior to operations to establish baseline ground water quality and then during operations to check for process constituents in the groundwater. The



monitoring wells will be suitably sized to permit installation of submersible pumps and operation as seepage recovery wells if required.

9.4.2 Basin Groundwater and Embankment Foundation Drains

Embankment foundation drains located immediately below the compacted till will relieve any groundwater or seepage pressures which may develop in the embankment foundations and will convey the resulting flows to the downstream toe of the embankments. Foundation drain outlets will be monitored for flow quantity and water quality. Foundation drain flows will be recycled to the tailings area.

Basin groundwater drains located within the impoundment will convey groundwater seepage from the glaciofluvial sediments in the same manner as the embankment foundation drains.

9.4.3 Toe Drain

The toe drains, shown on Dwg. No. 1625.111, serve to dewater the tailings beach as required for modified centreline raising of the embankment. The toe drain outlets will discharge to the drain monitoring sumps. The flows from the toe drains will be monitored and correlated to other instrumentation data.

9.4.4 Drain Monitoring Sump

A drain monitoring sump is provided upstream of the Main and Perimeter Embankment seepage collection ponds to allow flow measurements and water quality samples to be taken from the individual drains. The sumps will be constructed using 1.8 m dia by approximately 4 m deep manholes with a low level outlet to the seepage collection ponds as shown on Dwg. No. 1625.102.



9.4.5 Seepage Collection Pond Recycle Pumps

The seepage collection ponds are provided with recycle pump systems to pump the water back to the tailings storage facility. The seepage collection and recycle system is shown schematically in plan on Dwg. No. 1625.116. Conceptual details are shown on Detail A/1625.113. A 4 inch dia. DR21 HDPE pipeline would extend from the pumps directly to the crest of the tailings embankment by the shortest route and discharge directly onto the tailings beach.



SECTION 10.0 - OPERATION AND MONITORING

10.1 GENERAL

Geotechnical and environmental monitoring systems are essential for proper management of the tailings storage facility. The monitoring program will include the following:

- (i) Measurement of the rate of tailings accumulation.
- (ii) Operational monitoring of tailings characteristics (dry density, etc.) and water recoveries.
- (iii) Operational monitoring of supernatant pond depth, area and volume.
- (iv) Monitoring of piezometers installed in the tailings mass, underdrainage system and embankment zones.
- (v) Sampling of process water in the tailings pond and seepage recycle ponds for water quality analyses.
- (vi) Sampling of groundwater in monitoring wells GW95-1 to 3.
- (vii) Sampling of surface water streams down gradient of the facility for water quality analyses.
- (viii) Meteorological (rain, snow, evaporation) and air quality data collection.
- (ix) Flow monitoring in all seepage collections systems.
- (x) Flow monitoring in diversion ditches, runoff collection ditches, Polley Lake transfer, etc. for detailed on-going evaluation of water balance.



An Operations Manual will be developed for the tailings facility once detailed design of the various components is substantially complete.

The main objectives of the Operating Manual are to provide operational procedures and monitoring systems which will be implemented both prior to and during operations. In particular, the various components of the project water management plan will be identified and specific operational and monitoring requirements will be itemized so that the objective of storing sufficient runoff water in the tailings facility for mill operations is maintained, while simultaneously preventing the accumulation of excess water in the tailings impoundment during on-going operations.

A fundamental component of the operating strategy for the tailings facility is related to the method of controlled tailings discharge from several spigots located along the crest of the Perimeter and Main embankments. Tailings will be deposited in a controlled rotational manner wherein about 8 to 10 spigots are operated for a few days, and then deposition is transferred to the next 8 to 10 spigots for a few days, etc. Using this method, extensive tailings beaches will develop adjacent to the Perimeter and Main embankments as illustrated on Dwg. No. 1625.130.

10.2 INSTRUMENTATION

The required geotechnical instrumentation for Stage Ib construction is illustrated on Dwg. No. 1625.120. A series of vibrating wire piezometers will be installed along 3 main instrumentation planes. These piezometers will monitor pore pressures at:

- basin groundwater drains
- embankment foundation drains
- embankment toe drains
- embankment fill (both during construction and during impoundment filling)
- embankment foundation, and
- tailings, inside the impoundment (future).

The electric piezometer leads will be extended to a common monitoring hut located downstream of the final embankment toe, as shown on Dwg. No. 1625.120.



Surface movement monuments will also be installed on the crests of the embankment each year to monitor settlement. End of construction and beginning of construction embankment crest surveys will also be carried out for each staged expansion raise.

Instrumentation details are shown on Dwg. No. 1625.121.

The instrumentation systems will be upgraded as required by the Engineer during each staged expansion of the tailings embankment. The locations and details of the additional piezometers and surface movement monuments will be established during detailed design of each staged expansion.



SECTION 11.0 - RECLAMATION

11.1 GENERAL

In accordance with requirements under the *B.C. Mines Act* and *Health, Safety and Reclamation Code for British Columbia*, the primary objective of the proposed Reclamation Plan will be to return the tailings impoundment to an equivalent pre-mining use and capability. This comprises forested wildlife habitat that supports grazing, hunting, guiding, trapping and recreational uses. The following goals are implicit in achieving this primary objective:

- the long-term preservation of water quality within and downstream of decommissioned operations;
- the long-term stability of the tailings impoundment;
- the regrading of all access roads, ponds, ditches and borrow areas not required beyond mine closure;
- the removal and proper disposal of all pipelines, structures and equipment not required beyond mine closure;
- the long-term stabilization of all exposed erodible materials;
- the natural integration of disturbed lands into surrounding landscape, and restoration of the natural appearance of the area after mining ceases, to the greatest possible extent; and
- the establishment of a self-sustaining vegetative cover consistent with existing forestry, grazing and wildlife needs.

As an overall approach to achieving these objectives, the Reclamation Plan is sufficiently flexible to allow for future changes in the mine plan and to incorporate



information obtained from ongoing reclamation research programs such as trial tailings re-vegetation plots.

11.2 TOPSOIL STOCKPILING

Detailed requirements for salvage and stockpiling of surficial materials from the tailings impoundment are presently being developed. Soil surveys will be completed to describe soil characteristics, soil volumes and to select soil stockpile areas. The preferred locations for soil stockpiling, which are shown on the Drawings, have been selected to minimize conflicts with on-going site development and to ensure that the stockpiles are situated within the catchment area of the tailings impoundment and upgradient of the sediment control features.

11.3 DECOMMISSIONING AND CLOSURE

Since the tailings have been confirmed to be non-acid generating, the tailings surface will be decommissioned as a mixed forested/wetlands complex with a gradual transition towards a ponded area at an overflow spillway as shown on Dwg. No. 1625.140. The downstream face of the tailings dam will be revegetated progressively during operations as each embankment lift is completed, starting after Stage III (Year 2000) once the final toe position and slope have been established.

On mine closure, surface facilities will be removed in stages, salvaged and sold. The tailings delivery system will be dismantled and removed immediately following cessation of operations, but the supernatant reclaim barge, reclaim pumps and reclaim water line will be utilized for supplementary flooding of the open pit and will then be dismantled and removed. The seepage collection ponds and recycle pumps will be retained for one or two years after closure or until monitoring results indicate that tailings area seepage is of suitable quality for direct release to the environment. At that time, the seepage collection pond and pumps will be removed. However, the groundwater monitoring wells and monitoring piezometers in the tailings embankment will be retained for use as long term monitoring devices.



A dual level spillway will be constructed, with the lower level designed to accommodate the 1-in-200 year flood flows and the second capable of accommodating the Probable Maximum Flood (PMF) within the tailings basin. The lower spillway, which will include the outflow channel, will be constructed in competent ground adjacent to the South Embankment and will discharge to the Edney Creek north tributary drainage. The elevation of this spillway and outflow channel will be designed to establish a set water elevation over the tailings surface (approximately 15% coverage). A secondary, or emergency overflow spillway section, will be designed to accommodate the PMF and maintain sufficient freeboard within the impoundment. This secondary spillway is required in the event that beavers, ice or debris block the lower spillway and outflow channel.

Before the final tailings impoundment flooding to the required pond elevation, the area along the final water level will be sculptured using conventional earthmoving equipment to create a series of small bays and channels which will become a margin environment conducive to the creation of waterfowl breeding and staging habitat. The tailings embankments and the upland portions of the exposed tailings beach will be covered with a layer of soil, stockpiled during construction, and revegetated with indigenous species of conifer and deciduous trees, willow and marsh land grasses. The moist transition zone between the topsoiled beach and final pond will be revegetated as a early seral stage meadow, leading to aquatic tolerant, emergent and submerged aquatic species of plant. Native vegetation species, occurring in areas where drainage is impeded or swampy, will be utilized for these transition zones. Where necessary, the final tailings surface will be treated with amendments suitable for sustaining permanent growth. The shoreline will then be planted with native emergent plant species for cover. Most of the expected species may transplanted from nearby wetlands of a similar aspect and elevation or propagated from root cuttings, turf squares or offsets.

The advice of organizations such as the B.C, Fish and Wildlife Branch, Ducks Unlimited and local trappers/guided outfitters will be sought during final design.

Final seeding of the embankment slopes with grasses and legumes will provide a stable vegetation mat that resists erosion. Once open pit flooding is complete, the



surface water diversion system will be dismantled to allow for natural runoff to be routed through the tailings area.



SECTION 12.0 - REFERENCES

- Knight and Piésold Ltd., 1990. "Report on Geotechnical Investigations and Design of Open Pit, Waste Dumps and Tailings Storage Facility".
- Knight Piésold Ltd., 1995. "Report on 1995 Geotechnical Investigations for Mill Site and Tailings Storage Facility, Ref. No. 1623/1".
- Knight Piésold Ltd., 1995. "Report on Project Water Management, Ref. No. 1624/1".
- Knight Piésold Ltd., 1995. "Site Inspection Manual, Ref. No. 1625/2".
- Knight Piésold Ltd., 1995. "Technical Specifications, Ref. No. 1625/3".
- Basham, P.W., Weichert, D.H., Anglin, F.M., and Berry, M.J., 1982. "New Probabilistic Strong Seismic Ground Motion Maps of Canada: A Compilation of Earthquake Source Zones, Methods and Results", Earth Physics Branch Open-File Report 22-33.
- Cornell, C.A., 1968. "Engineering Seismic Risk Analysis", Bulletin of the Seismological Society of America, Vol. 58, No. 5, pp. 1583-1606.
- Idriss, I.M., 1993. "Procedure for Selecting Earthquake Ground Motions at Rock Sites", Report to U.S. Dept. of Commerce, NIST GCR 93-625.
- Seed, R.B. and Harder, L.F., 1990. "SPT-Based Analysis of Cyclic Pore Pressure Generation and Undrained Residual Strength", H. Bolton Seed Memorial Symposium, Vol. 2.
- Zarling, J.P., Nelson, W.G. and Ryan, W.L., November 1990. "Cold Regions Engineering Short Course", University of Alaska.



TABLE 2.1

IMPERIAL METALS CORPORATION
MT. POLLEY PROJECT

MEAN MONTHLY AND ANNUAL PRECIPITATION

	Likely, B.C.		Mine Site		Barkerville	
Location:	Likely, B.C.		Mine Site		Barkerville	
Elevation:	724 m		1000 m		1265	
Location:	52° 36'N 121° 32'W		52° 30'N 121° 35'W		53° 4'N 121° 31'W	
	<u>Mean</u> (mm)	<u>Std. Dev.</u> (mm)	<u>Mean</u> (mm)	<u>Std. Dev.</u> (mm)	<u>Mean</u> (mm)	<u>Std. Dev.</u> (mm)
Jan	74.2	27.0	75.5	27.0	103.0	44.4
Feb	60.2	27.7	58.1	27.7	85.6	42.5
Mar	37.8	13.5	44.5	13.5	85.3	29.1
Apr	42.2	20.9	43.1	20.9	61.8	24.5
May	36.6	15.4	50.6	15.4	65.9	28.9
June	66.3	29.7	81.5	29.7	89.2	28.8
July	47.0	27.4	65.7	27.4	81.7	31.0
Aug	82.0	35.7	83.1	35.7	102.3	53.0
Sept	50.4	27.1	60.4	27.1	85.4	39.9
Oct	61.6	42.3	60.4	42.3	88.4	37.4
Nov	58.4	18.8	57.3	18.8	86.6	28.2
Dec	83.0	36.9	74.8	36.9	108.7	42.5
Annual	699.7	116.4	755	116.4	1043.9	112.7

Source :

Canadian Climate Normals, 1951-1980, Temperature and Precipitation Atmospheric Environment Service, Environment Canada.



TABLE 2.2

**IMPERIAL METALS CORPORATION
MT. POLLEY PROJECT**

PRECIPITATION DETAILS USED IN ANALYSIS

J:\JOB\DATA\1624\WATERBAL\STATWBAL.XLS

4/4/95 9:01

DESCRIPTION	VALUE			
Lower Elevations (ie. TSF)				
Mean annual precipitation (mm)	755			
"Dry" annual precipitation (mm)	601			
"Wet" annual precipitation (mm)	909			
"Max." annual precipitation (mm)	1050			
"Min." annual precipitation (mm)	450			
Mean annual rainfall (mm)	451			
Mean annual snowfall (mm)	304			
Coefficient of variation	0.16			
Standard deviation (mm)	121			
Higher Elevations (ie. mill site, waste dumps)				
"Elevation" factor	1.07285			
Mean annual precipitation (mm)	810			
"Dry" annual precipitation (mm)	645			
"Wet" annual precipitation (mm)	975			
Coefficient of variation	0.16			
Standard deviation (mm)	130			
Proportions of Total Precipitation:				
Rainfall	0.60			
Snowfall	0.40			
Monthly Proportions of Precipitation:				
	Rainfall (mm)	Proportion as Rainfall	Snowfall (mm)	Proportion as Snowfall
Oct	48.3	0.11	12.1	0.04
Nov	17.3	0.04	40.0	0.13
Dec	7.6	0.02	67.2	0.22
Jan	6.8	0.02	68.7	0.23
Feb	6.0	0.01	52.1	0.17
Mar	6.0	0.01	38.5	0.13
Apr	24.2	0.05	18.9	0.06
May	45.3	0.10	5.3	0.02
Jun	81.5	0.18	0.0	0.00
Jul	65.7	0.15	0.0	0.00
Aug	83.1	0.18	0.0	0.00
Sep	58.9	0.13	1.5	0.00
Total (mm)	450.7		304.3	



TABLE 2.3

IMPERIAL METALS CORPORATION

MT. POLLEY PROJECT

ESTIMATED PAN EVAPORATION AT SITE

	<u>Quesnel</u>	<u>Williams Lake</u>	<u>Site</u>
May	98	88	93
June	130	124	127
July	151	144	148
August	131	129	130
September	81	77	79
October	<u>39</u>	<u>38</u>	<u>38</u>
Total	630	600	615

Source:

Based on computed potential evapotranspiration data by AES using Thornthwaite model, increased by an empirical factor of 1.25 to bring into line with pan evaporation data.



TABLE 2.4

IMPERIAL METALS CORPORATION
MT. POLLEY PROJECT

PROBABLE MAXIMUM PRECIPITATION

1 hour PMP	= 78 mm	= 78 mm/hour
6 hour PMP	= 88 mm	= 14.6 mm/hour
24 hour PMP	= 203 mm	= 8.5 mm/hour
10 day PMP	= 406 mm	= 1.7 mm/hr

Source :

Rainfall Frequency Atlas for Canada, W.D. Hogg, D.A. Carr, Supply and Services Canada 1985.

Note:

1. 24 hr. PMP value conservatively assumes an orographic factor of 1.5.
2. 10 day PMP value assumes a 10 day to 24 hour PMP ratio of 2.0.



TABLE 2.5

IMPERIAL METALS CORPORATION
MT. POLLEY PROJECT

USUAL MINIMUM CRITERIA FOR DESIGN EARTHQUAKES

Consequence Category	Maximum Design Earthquake (MDE)	
	Deterministically Derived	Probabilistically Derived (Annual exceedance probability)
Very High	MCE ^{abc}	1/10,000 ^{[b][c]}
High	50% to 100% MCE ^{de}	1/1000 to 1/10,000 ^[e]
Low	- ^f	1/100 to 1/1000 ^[f]

^a For a recognized fault or geographically defined tectonic province, the Maximum Credible Earthquake (MCE) is the largest reasonably conceivable earthquake that appears possible. For a dam site, MCE ground motions are the most severe ground motions capable of being produced at the site under the presently known or interpreted tectonic framework.

^b In Hydro-Québec's practice, the MDE for Very High Consequence structures involves a combination of deterministic and probabilistic approaches that reflect current knowledge of seismo-tectonic conditions in Eastern Canada. Hydro-Québec's deterministically derived MDE magnitude is the maximum historically recorded earthquake, increased by one-half magnitude, while their probabilistically derived earthquake has an estimated probability of exceedance of 1/2000.

^c An appropriate level of conservatism shall be applied to the factor of safety calculated from these loads, to reduce the risks of dam failure to tolerable values. Thus, the probability of dam failure could be much lower than the probability of extreme event loading.

^d MDE firm ground accelerations and velocities can be taken as 50% to 100% of MCE values. For design purposes the magnitude should remain the same as the MCE.

^e In the High Consequence category, the MDE is based on the consequences of failure. For example, if one incremental fatality would result from failure, an AEP of 1/1000 could be acceptable, but for consequences approaching those of a Very High Consequence dam, design earthquakes approaching the MCE would be required.

^f If a Low Consequence structure cannot withstand the minimum criteria, the level of upgrading may be determined by economic risk analysis, with consideration of environmental and social impacts.



TABLE 5.1

**IMPERIAL METALS CORPORATION
MT. POLLEY PROJECT**

**SUMMARY OF LABORATORY TESTS
INDEX TEST RESULTS**

J:\JOB DATA\1623 LAB TEST.XLS

Apr 5 '95 2:12 pm

Test Pit Sample No.	Location	Specific Gravity	Natural Moisture Content (%)	Atterberg Limits (%)				Grain Size Distribution				Soil Description
				LL	PL	PI	LI	+ #4	#4 - #200	#200 - 0.002mm	-0.002mm	
								% Gravel	% Sand	% Silt	% Clay	
TP95-18	Tailings/Reclaim Pipeline Route	-	13.8	27	13	14	0.0	38	36	19	7	GRAVEL and SAND, some silt, trace clay (TILL)
TP95-27	Perimeter Embankment Foundation	2.73	11.1	22	14	9	-0.3	19	37	33	11	SAND and SILT, some gravel and clay (TILL)
TP95-31	East Ridge Borrow Area	-	11.0	22	14	8	-0.4	41	27	25	7	Silty, sandy GRAVEL, trace clay (TILL)
TP95-35	South Basin	2.78	16.5	21	14	7	0.4	2	22	65	11	Sandy SILT, some clay, trace gravel
TP95-37	South Basin	-	18.8	27	16	11	0.2	14	40	35	11	SAND and SILT, some gravel and clay (TILL)
TP95-38	Main Embankment Foundation	2.79	28.4	33	19	14	0.7	3	6	73	18	SILT, some clay, trace sand and gravel
TP95-39	Main Embankment Foundation	2.76	28.5	-	-	-	-	0	40	46	14	SILT and fine SAND, some clay
TPB-1	Main Embankment Foundation	-	13.7	29	19	10	-0.5	3	14	67	16	SILT, some clay and sand, trace gravel (TILL)
TPB-13,14,16	Embankment & Pond Foundations	2.76	25.1	30	16	14	0.6	1	17	61	21	Clayey SILT, some sand, trace gravel

Note: 1. Samples TPB-1 and TPB-13,14,16 were selected for laboratory testwork in 1989 and have been reported for comparison.

TABLE 5.2

**IMPERIAL METALS CORPORATION
MT. POLLEY PROJECT**

**SUMMARY OF LABORATORY TESTS
EFFECTIVE STRENGTH PARAMETERS, COMPACTION AND PERMEABILITY TEST RESULTS**

J:\JOB DATA\1623 LAB TEST.XLS

Apr 5 '95 2:08 pm

Test Pit Sample No.	Location	EFFECTIVE STRENGTH PARAMETERS		COMPACTION			PERMEABILITY	Soil Description
		Friction Angle, ϕ' (degrees)	Cohesion, c' (kPa)	Natural Moisture Content (%)	Optimum Moisture Content (%)	Maximum Dry Density (kg/m^3)	Permeameter Falling Head Test (cm/sec)	
TP95-18	Tailings/Reclaim Pipeline Route	-	-	13.8	10.1	2130	-	GRAVEL and SAND, some silt, trace clay (TILL) SAND and SILT, some gravel and clay (TILL)
TP95-27	Perimeter Embankment Foundation	35	0	11.1	8.0	2200	4×10^{-8}	
TP95-31	East Ridge Borrow Area	-	-	11.0	7.6	2200	6×10^{-8}	Silty, sandy GRAVEL, trace clay (TILL)
TP95-35	South Basin	-	-	-	-	-	7×10^{-7}	Sandy SILT, some clay, trace gravel
TP95-37	South Basin	35	0	-	-	-	-	SAND and SILT, some gravel and clay (TILL)
TP95-38	Main Embankment Foundation	-	-	-	-	-	3×10^{-7}	SILT, some clay, trace sand and gravel
TP95-39	Main Embankment Foundation	33	0	-	-	-	2×10^{-6}	SILT and fine SAND, some clay
TPB-13,14,16	Embankment & Pond Foundations	-	-	25.1	13.3	1935	2×10^{-8}	Clayey SILT, some sand, trace gravel (TILL)

Notes:

1. Triaxial tests results from samples TP95-27 and 37 were combined to determine average strength parameters for the glacial till material.
2. Compaction tests performed as per ASTM D1557 Modified Proctor tests.
3. Permeability tests carried out on samples compacted with standard proctor energy and at natural moisture content.
4. Sample TPB-13,14,16 was selected for laboratory testwork in 1989 and has been reported for comparison.

TABLE 6.1

**IMPERIAL METALS CORPORATION
MT. POLLEY PROJECT**

SUMMARY OF DESIGN CRITERIA FOR TAILINGS IMPOUNDMENT

1.0 GENERAL DESIGN CRITERIA	
Item	Design Criteria
Scope	Generally applicable to all components and structures including those itemized in the sections that follow
Regulations	MEMPR MOELP (Water Management Branch) IHSR ^[1]
Codes and Standards	NBC and related codes CAN/CSA HSRC ^[2] ASTM ACI ANSI
Design Life	14 Years
Operational Criteria: General	NBC where relevant
Rainfall/Precip:	Section 2.1 plus Report on Project Water Management (Ref. No. 1624/1)
Seismic	
DBE (operations)	M = 6.5, A max = 0.037 g
MDE (closure)	M = 6.5, A max = 0.065 g

Notes:

1. IHSR = Industrial Health and Safety Regulations from WCB
2. HSRC = Health, Safety and Reclamation Code for Mines in British Columbia



TABLE 6.1 (Cont'd)

IMPERIAL METALS CORPORATION
MT. POLLEY PROJECT

SUMMARY OF DESIGN CRITERIA FOR TAILINGS IMPOUNDMENT

2.0 TAILINGS BASIN	
Item	Design Criteria
Site Selection	Section 4.0 and Ref. No. 1621/1 <ul style="list-style-type: none"> • Capacity and filling characteristics. • Hydrology and downstream water usage. • Hydrogeology and groundwater regime. • Aesthetics and visual impact. • Foundation conditions. • Construction requirement. • Closure and reclamation requirements. • Capital and operating costs.
Geotechnical Conditions	Section 5.0 and Ref. No. 1623/1
Basin Liner	<ul style="list-style-type: none"> • Compacted glacial till with frost protection layer required in areas of < 2 m in-situ glacial till thickness. • Till liner placed in 3 - 150 mm lifts. • Till liner compacted to 95% max dry density relative to Modified Proctor ASTM D1557 at optimum moisture content minus 1% to plus 2%.
Basin Groundwater Drains	<ul style="list-style-type: none"> • To be installed in areas requiring basin liner. • Geotextile wrapped 1 m x 1 m gravel/drain with 4" perf. CPT drain pipe. • GW drain conveyance pipes are HDPE. • Discharge is to seepage pond via drain monitoring sump.
Stripping	<ul style="list-style-type: none"> • Remove organic soil to topsoil stockpiles. • Swamp areas to be stripped to limits of access for construction equipment.



TABLE 6.1 (Cont'd)

**IMPERIAL METALS CORPORATION
MT. POLLEY PROJECT**

SUMMARY OF DESIGN CRITERIA FOR TAILINGS IMPOUNDMENT

3.0 TAILINGS EMBANKMENT		
Item		Design Criteria
Function		<ul style="list-style-type: none"> Storage of tailings and process water for design life. Provide storage for 24 hour PMP storm. Provision for routing PMF at closure.
Embankment Crest Width		8 m starter dam; 8 m ultimate.
Embankment Height (Max):	Starter	17 m
	Final	50 m
Embankment Crest Length:	Starter	500 m
	Final	4300 m
Design Tonnage		13,425 tpd
Solids Content of Tailings Stream		<ul style="list-style-type: none"> 35% Provision for millsite and waste dump runoff addition to tailings stream.
Freeboard:	Operations	2 million m ³ , plus 24 hour PMP event. <i>+1m. WRU</i>
	Closure	Sufficient to provide routing of PMF plus wave run-up.
Storage Capacity		68.6 million tonnes.
Tailings Density:	Year 1	1.1 t/m ³
	Year 2	1.2 t/m ³
	Year 3-14	1.3 t/m ³
Tailings Specific Gravity		2.78
Borrow Material Properties		1995 Site Investigation Report (Ref. No. 1623/1), plus Section 5.2.
Construction Diversion		Not required.
Emergency Spillway Flows:	Operations	Not required.
	Closure	Design flow for routing PMF event.
Filling Rate		Ref. No. 1625/1, Figure 6.3.
Fill Material Properties		Dwg. No. 1625.112
Compaction Requirements		Dwg. No. 1625.111
Geotechnical Data		1995 Site Investigation Report (Ref. No. 1623/1), plus Section 5.1
Stability Analysis		Section 6.6
Seepage Analysis		Section 7.0
Sediment Control		Primary sediment pond is tailings basin upstream of Main Embankment. Secondary sediment pond downstream of Main Embankment at Bootjack - Morehead Connector.
Seepage Control		Seepage collection pond and pumpback well system.
Seismic Parameters		Section 2.3, Ref. No. 1625/1.
Spillway Discharge Capacity		Not required during operations,
Settlement		To be determined (see Section 6.0).
Surface Erosion Protection		Revegetation with grasses during ongoing construction.



TABLE 6.1 (Cont'd)

**IMPERIAL METALS CORPORATION
MT. POLLEY PROJECT**

SUMMARY OF DESIGN CRITERIA FOR TAILINGS IMPOUNDMENT

4.0 PIPEWORKS	
Item	Design Criteria
4.1 Tailings Delivery and Discharge Pipework	Ref. No. 1625/1 Section 9.2 and Dwg. Nos. 1625.116/117
Function	Transport tailings slurry and millsite - waste dump runoff to TSF.
Tailings Pipeline	<ul style="list-style-type: none"> Free draining, gravity flow pipeline. Butt fusion welded HDPE 22" dia. DR21.
Spigots	<ul style="list-style-type: none"> Pipeline sectioned by in-line valves on tailings embankment crest. Low pressure spigots will be scissor clamps. High pressure spigots will be pinch valves.
Flow Rate	<ul style="list-style-type: none"> Design throughput 720 tonnes/hr dry solids. Slurry solids content 35%. Design flow 15.7 cfs (0.44 m³/s). Millsite and waste dump runoff will be added to tailings stream, increasing flow and decreasing solids content.
Spill Containment:	
- Millsite to Bootjack Creek	Pipeline buried in compacted glacial till.
- Bootjack Creek Crossing	Pipe sleeves draining to pipe containment channel.
- Bootjack Creek to TSF	Pipe containment channel.
Millsite and Waste Dump Runoff	<ul style="list-style-type: none"> Collected in sediment control ponds. Added to tailings stream at in-line drop boxes. See Drawing No. 1625.116
4.2 Reclaim Water System	
Function	Primary source of water for milling process.
Reclaim Barge	<ul style="list-style-type: none"> Prefabricated floating pump station located in excavated channel in TSF. Local and remote control from millsite.
Reclaim Pipeline	24" HDPE pipeline, pressure ratings vary along length.
Reclaim Booster Pump Station	<ul style="list-style-type: none"> Prefabricated pump station located halfway between TSF and millsite. Same pumps, sensors and controls as on reclaim barge for ease of maintenance.
Spill Containment	<ul style="list-style-type: none"> See Item 4.1 above, all same for pipelines. Booster pump station has closed sump.
4.3 Seepage Recycle System	
Function	Return seepage flows to TSF.
Drain Monitoring Sumps	Flow quantity and water quality measurements on individual drains.
Seepage Collection Ponds	<ul style="list-style-type: none"> Sized to hold 10 times max weekly flow quantity. Clay lined or operated as groundwater sink.
Seepage Recycle Pumps	<ul style="list-style-type: none"> Set in vertical CSP pump sumps. 4" submersible pumps. Pumps discharge back to TSF via 4" HDPE pipes.



TABLE 6.1 (Cont'd)

**IMPERIAL METALS CORPORATION
MT. POLLEY PROJECT**

SUMMARY OF DESIGN CRITERIA FOR TAILINGS IMPOUNDMENT

5.0 DIVERSION DITCHES/ACCESS ROADS	
Item	Design Criteria
5.1 General	
Function	Selective diversion of water into TSF to meet Water Management Plan objectives.
Reference	<ul style="list-style-type: none"> Section 8.3.2, Appendix A Dwg. Nos. 1625.114 and 1625.115.
5.2 Area B Runoff Collection Ditch	
Catchment Area	350 ha (approx)
Ditch Section	3:1 sides, 2.5 m wide bottom
Ditch Profile	See Dwg. No. 1625.114
Design Flood Event	1 in 10 yr storm runoff
Design Basis Flows	1 in 50 yr storm runoff
Hydrologic Design	<ul style="list-style-type: none"> IDF curve from Ref. No. 1621/1. Time of Concentration from Hathaway Formula and from MOE Manual of Hydrology Fig. 7.5.3.
Hydraulic Design	Manning equation, $n = 0.025$
Riprap Design	MOTH Design Manual, Riprap Design Chart E.3-3.11.
Flow Control Structures	See Dwg. No. 1625.115 for layout details and depth - discharge curve for flow rating.
Flow Monitoring	Parshall Flume at TSF entrance.
5.3 Diversion Ditch above TSF	
Design Flood Event	1 in 10 yr storm runoff
Design Basis Flows	1 in 50 yr storm runoff
Hydrologic Design	<ul style="list-style-type: none"> IDF curve from Ref. No. 1621/1. Time of Concentration from Hathaway Formula and from MOE Manual of Hydrology Fig. 7.5.3.
Hydraulic Design	Manning equation, $n = 0.025$
Riprap Design	MOTH Design Manual, Riprap Design Chart E.3-3.11.
5.4 Pipe Containment Channel	
Catchment Area	36 ha
Ditch Section	2:1 sides, 1.5 m bottom.
Ditch Profile	1% to separation point of pipelines.
Design Flood Event	1 in 10 yr storm runoff
Design Basis Flows	1 in 50 yr storm runoff
Hydrologic Design	<ul style="list-style-type: none"> IDF curve from Ref. No. 1621/1. Time of Concentration from Hathaway Formula and from MOE Manual of Hydrology Fig. 7.5.3.
Hydraulic Design	Manning equation, $n = 0.025$
Riprap Design	MOTH Design Manual, Riprap Design Chart E.3-3.11.



TABLE 6.1 (Cont'd)

IMPERIAL METALS CORPORATION
MT. POLLEY PROJECT

SUMMARY OF DESIGN CRITERIA FOR TAILINGS IMPOUNDMENT

6.0 INSTRUMENTATION AND MONITORING	
Item	Design Criteria
6.1 General	
Function	To quantify environmental conditions and performance characteristics of the TSF to ensure compliance with design objectives.
Reference	<ul style="list-style-type: none"> • Section 10.0 • Dwg. No. 1625.120
6.2 Geotechnical I & M	
Piezometers	<ul style="list-style-type: none"> • Measure pore pressures in drains, foundations, fills and tailings. • Vibratory wire <u>electrical piezometers</u>. • Installed by qualified technical personnel. • Two instrumentation planes for main embankment.
Survey Monuments	<ul style="list-style-type: none"> • <u>Deformation and settlement monitoring of embankments.</u>
6.3 Flow Monitoring	<ul style="list-style-type: none"> • To provide data for on-going water balance calculations. • Parshall Flume for runoff diversion inflows to TSF. • Drain flows regularly monitored. • Reclaim and seepage pump systems flow meters. • Tailings output monitored at millsite. • Streamflow monitoring.
6.4 Water Quality Monitoring	<ul style="list-style-type: none"> • To ensure environmental compliance. • Water quality samples taken at regular intervals from sediment ponds, drains (at drain monitor sump), groundwater monitoring wells, seepage ponds and tailings pond. • Upstream and downstream samples for impact analysis.
6.5 Hydrometeorology	<ul style="list-style-type: none"> • Operator weather station for input to water balance calculations. • Precipitation (rain and snow). • Evaporation. • Air quality monitoring (dust, etc.).
6.6 Operational Monitoring	<ul style="list-style-type: none"> • Quantify operation of tailings storage facility. • Rate of tailings accumulation in terms of mass and volume. • Tailings characteristics and water recovery. • Supernatant pond (depth, area and volume).



TABLE 6.1 (Cont'd)

IMPERIAL METALS CORPORATION
MT. POLLEY PROJECT

SUMMARY OF DESIGN CRITERIA FOR TAILINGS IMPOUNDMENT

7.0 CLOSURE REQUIREMENTS	
Item	Design Criteria
7.1 General	Return impoundment to equivalent pre-mining use and productivity by establishing a small pond adjacent to a final spillway and revegetating remainder of tailings surface with indigenous species of trees, shrubs and grasses adjacent to embankment grading to aquatic species along and adjacent to final pond.
7.2 Spillway	Two stage spillway with lower channel outlet designed to pass 1 in 200 yr 24 hour flood event and upper wider outlet section designed to pass Probable Maximum Flood without overtopping embankments.

Notes:

1. The closure plan will remain flexible during operations to allow for future changes in the mine plan and to incorporate information from on-going reclamation programs.



TABLE 6.2

IMPERIAL METALS CORPORATION
MT. POLLEY PROJECT

CONSEQUENCE CLASSIFICATION OF DAMS

Consequence Category	Potential Incremental Consequences of Failure ^[a]	
	Loss of Life	Economic, Social, Environmental
Very High	Large increase expected ^[b]	Excessive increase in social, economic and/or environmental losses
High	Some increase expected ^[b]	Substantial increase in social, economic and/or environmental losses.
Low	No increase expected	Low social, economic and/or environmental losses.
Very Low	No increase	Small dams with minimal social, economic and/or environmental losses. Losses generally limited to the owner's property; damages to other property are acceptable to society.

^[a] Incremental to the impacts which would occur under the same natural conditions (flood, earthquake event) but without failure of the dam. The type of consequences (e.g. loss of life, or economic losses) with the highest rating determines which category is assigned to the structure.

^[b] The loss-of-life criteria which separate the High and Very High categories may be based on risks which are acceptable or tolerable to society, taken to be 0.001 lives per year for each dam. Consistent with this tolerable societal risk the minimum criteria for a Very High Consequence dam (PMF and MCE) should result in an annual probability of failure of less than 1/100,000.



TABLE 6.3

**IMPERIAL METALS CORPORATION
MT. POLLEY PROJECT**

STAGED EMBANKMENT FILL QUANTITIES

J:\JOB\DATA\1625\STGDQTYR.XLT

4/6/95 14:29

MATERIAL ZONE	FILL QUANTITY BY STAGE (m ³) ^(1,2)									TOTAL (m ³)
	Ia(1995)	Ib(1996)	Ic(1997)	II(1998)	III(2000)	IV(2002)	V(2004)	VI(2006)	VII(2008)	
CBL: free draining random fill ⁽³⁾	-	-	11,000	37,800	-	-	-	12,700	12,900	74,400
Chimney Drain: clean sand and gravel	-	2,900	6,900	13,800	-	-	-	-	-	23,600
Toe Drain: clean sand and gravel	-	1,400	900	1,100	300	300	100	100	100	4,300
S: Glacial Till, core zone	177,500	50,600	59,300	109,800	130,600	168,800	157,500	149,200	152,100	1,155,400
A: Glacial Till, upstream shell	-	-	47,500	84,400	-	-	-	10,200	10,400	152,500
B: Glacial Till, downstream shell	69,700	189,100	-	-	-	-	-	-	-	258,800
C: Random Fill, downstream shell	-	-	337,900	172,100	882,000	339,100	278,200	190,300	136,500	2,336,100
CS: Cyclone Sand, upstream shell	-	-	-	-	135,200	119,700	125,800	163,700	133,800	678,200
TOTALS	247,200	244,000	463,500	419,000	1,148,100	627,900	561,600	526,200	445,800	4,683,300

- Notes:
1. All quantities listed above are neat line + 10% contingency.
 2. No allowance has been added for cut to fill shrinkage.
 3. Coarse Bearing Layer material type dependent on tailings beach development; to be determined prior to construction.

TABLE 7.1

IMPERIAL METALS CORPORATION
MT. POLLEY PROJECT

SUMMARY OF MATERIAL PARAMETERS
FOR SEEPAGE ANALYSES

Material		Saturated Hydraulic Conductivity (cm/s)
Zone No.	Description	
1	Tailings (above el. 945 m)	1×10^{-5}
2	Tailings (el. 931 - 945 m)	5×10^{-6}
3	Tailings (below el. 931 m)	1×10^{-6}
4	Coarse Tailings	5×10^{-5} (Horiz) 1×10^{-5} (Vert)
5	Zone A - Glacial Till	1×10^{-6}
6	Chimney Drain - Coarse Filter Material	1×10^{-4}
7	Zone S - Low Permeability Glacial Till	1×10^{-7}
8	Zone B - Glacial Till	1×10^{-6}
9	Clay Liner/Foundation Glacial Till	1×10^{-7} to 1×10^{-6}
10	Foundation Drain	1×10^{-2}
11	Zone C - Random Fill	1×10^{-5}
12	Zone CS - Cyclone Sand	1×10^{-4}
13	Glaciofluvial/Lacustrine Deposits	1×10^{-5} (Horiz) 1×10^{-6} (Vert)
14	Volcanic Conglomerate	1×10^{-6}

Check in field during construction



TABLE 7.2

IMPERIAL METALS CORPORATION
MT. POLLEY PROJECT

SUMMARY OF SEEPAGE ANALYSIS RESULTS

Case 1: Permeability of foundation glacial till = 1×10^{-7} cm/s

Component	Embankment						Grand Total	
	Main Length = 1200m		Perimeter Length = 2160m		South Length = 1100 m		Litres /sec	Gal/ min
	Seepage (m ³ /s/m)	Total (m ³ /s)	Seepage (m ³ /s/m)	Total (m ³ /s)	Seepage (m ³ /s/m)	Total (m ³ /s)		
U/S Toe Drain	1.10E-06	1.32E-03	7.52E-07	1.62E-03	0.00E+00	0.00E+00	2.9	39
Foundation Drain	4.20E-07	5.04E-04	0.00E+00	0.00E+00	0.00E+00	0.00E+00	0.5	7
Seepage Loss	1.30E-07	1.56E-04	7.05E-08	1.52E-04	7.38E-08	8.12E-05	0.4	5
Total	1.65E-06	1.98E-03	8.23E-07	1.78E-03	7.38E-08	8.12E-05	3.8	51

Case 2: Permeability of foundation glacial till = 1×10^{-6} cm/s

Component	Embankment						Grand Total	
	Main Length = 1200m		Perimeter Length = 2160m		South Length = 1100 m		Litres /sec	Gal/ min
	Seepage (m ³ /s/m)	Total (m ³ /s)	Seepage (m ³ /s/m)	Total (m ³ /s)	Seepage (m ³ /s/m)	Total (m ³ /s)		
U/S Toe Drain	1.10E-06	1.32E-03	8.49E-07	1.83E-03	0.00E+00	0.00E+00	3.2	42
Foundation Drain	5.70E-07	6.84E-04	0.00E+00	0.00E+00	0.00E+00	0.00E+00	0.7	9
Seepage Loss	1.50E-07	1.80E-04	1.24E-07	2.68E-04	1.23E-07	1.35E-05	0.6	8
Total	1.82E-06	2.18E-03	9.73E-07	2.10E-03	1.23E-07	1.35E-04	4.5	59



IMPERIAL METALS CORPORATION
MT. POLLEY PROJECT
PROJECT LOCATION MAP



CAD FILE: \PROJECT\1625\FIG\A3 Plot scale 1=1

0 100 200 MILES
0 100 200 300 KILOMETRES

March 21, 1995
KNIGHT PIESOLD LTD.
CONSULTING ENGINEERS

FIGURE 1.1

IMPERIAL METALS CORPORATION
MT. POLLEY PROJECT
LOCATION OF WEATHER STATIONS

⊙ Project location
 □ Weather Station

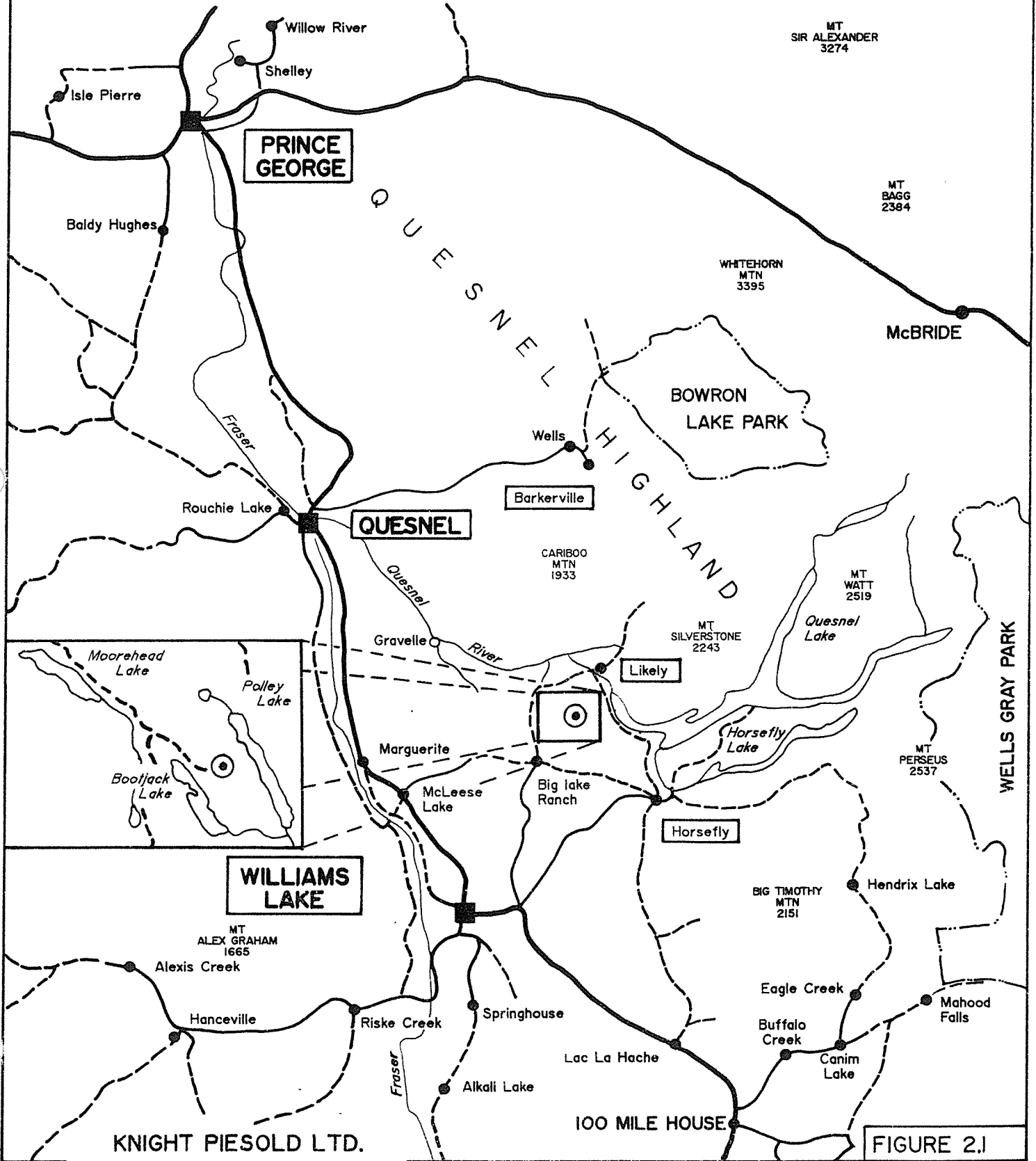
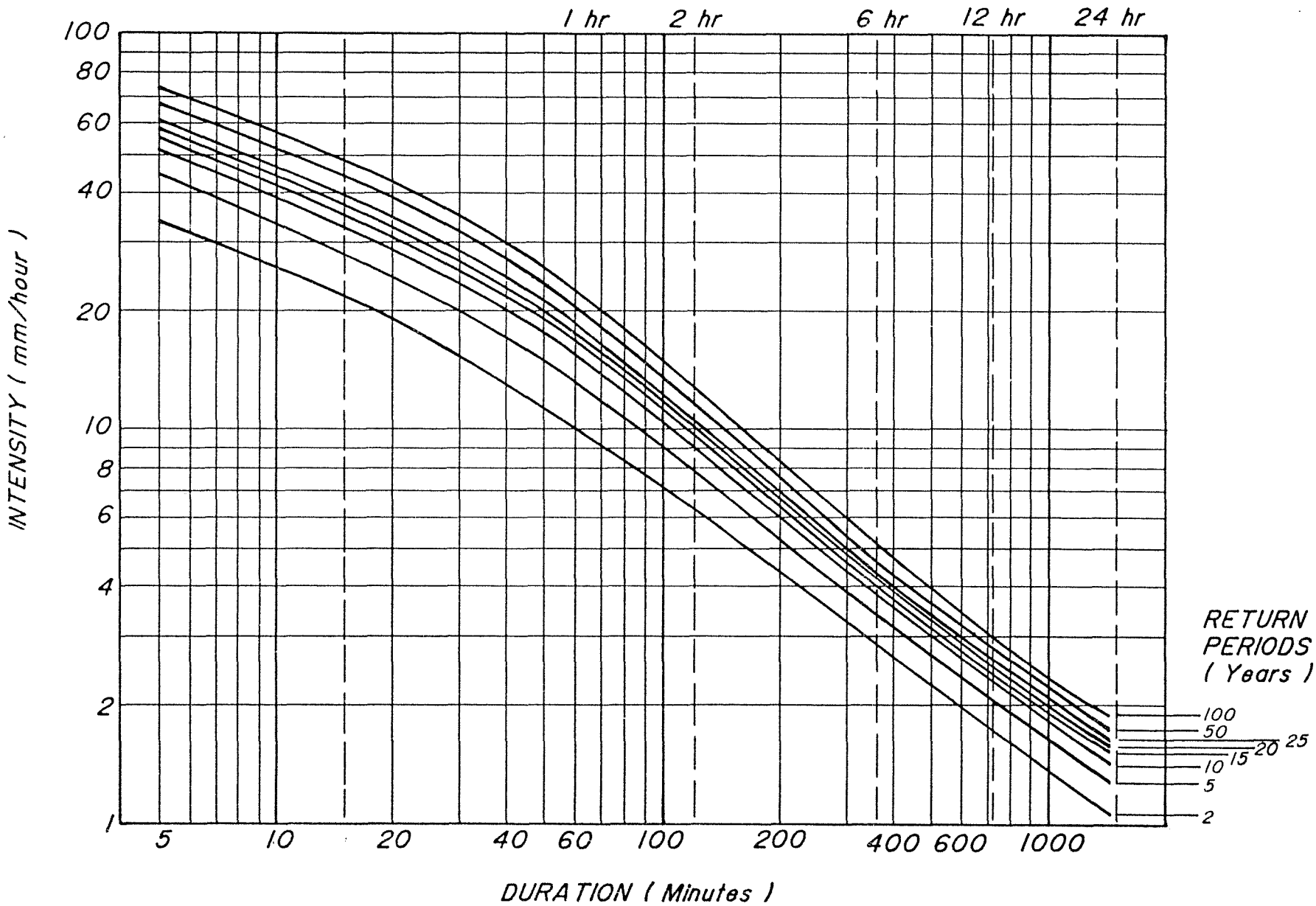

FIGURE 2.1

IMPERIAL METALS CORPORATION
MT. POLLEY PROJECT

SHORT DURATION RAINFALL INTENSITY - DURATION - FREQUENCY DATA FOR MINE SITE



March 20, 1995
KNIGHT PIESOLD LTD.
CONSULTING ENGINEERS

FIGURE 2.2

IMPERIAL METALS CORPORATION MT. POLLEY PROJECT TAILINGS AREA ALTERNATIVES



March 20, 1995
KNIGHT PIESOLD LTD.
CONSULTING ENGINEERS

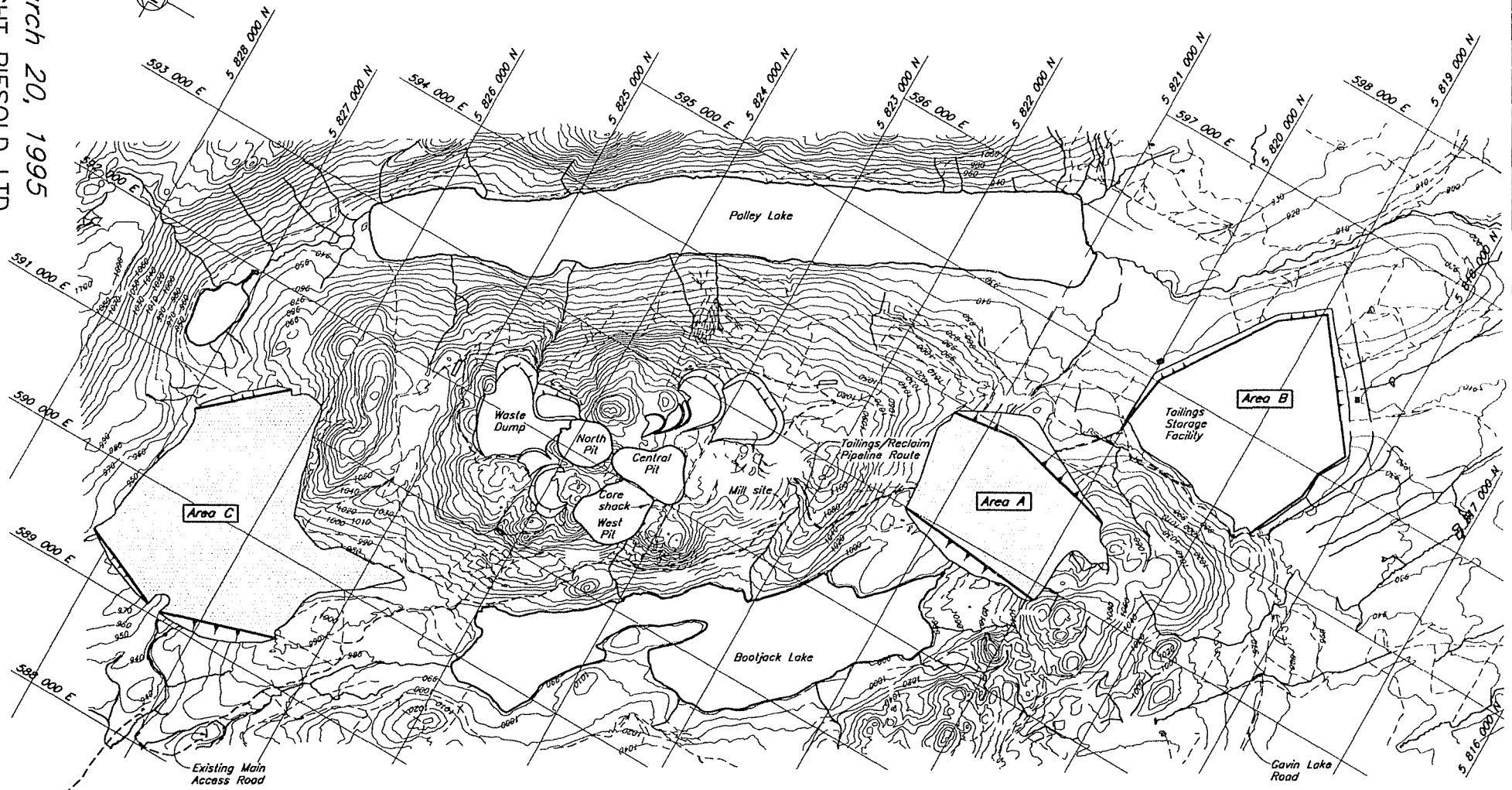

FIGURE 4.1



IMPERIAL METALS CORPORATION - MT. POLLEY PROJECT
 STAGE 1b 1995 TAILINGS STORAGE FACILITY CONSTRUCTION SCHEDULE

Task Name	Duration	Start	Finish	June			July			August				September				October									
				5/22	5/29	6/5	6/12	6/19	6/26	7/3	7/10	7/17	7/24	7/31	8/7	8/14	8/21	8/28	9/4	9/11	9/18	9/25	10/2	10/9	10/16	10/23	10/30
SITE ROADS AND DIVERSION DITCHES	119d	6/1/95	9/27/95																								
Tree Clearing (by Others)	14d	6/1/95	6/14/95			////																					
Stripping, Grubbing and Topsoil windrowing	14d	6/23/95	7/6/95					////																			
Redistribution of Topsoil	10d	9/18/95	9/27/95																			////					
Construct Bootjack-Morehead Relocation	21d	6/23/95	7/13/95					////																			
Supply/install CSP culverts	35d	7/3/95	8/6/95						////																		
Construct Flow Control Structures	21d	7/24/95	8/13/95							////																	
Construct Area B/C Runoff Collection Ditch	42d	7/17/95	8/27/95								////																
Placement of Riprap in Area B/C Runoff Collection Ditch	14d	8/14/95	8/27/95									////															
Grade Tailings and Reclaim Access Roads	7d	9/11/95	9/17/95																			////					
Construct Tailings Area Diversion Ditch	21d	8/28/95	9/17/95																			////					
Compaction	87d	6/23/95	9/17/95					////														////					
INSTRUMENTATION AND MONITORING FACILITIES	115d	6/19/95	10/11/95																								
Grout Existing Boreholes	7d	6/19/95	6/25/95				////																				
Piezometer Equipment Supply	7d	6/19/95	6/25/95				////																				
Piezometer Equipment Installation	84d	6/26/95	9/17/95					////														////					
Monitoring Hut	7d	8/14/95	8/20/95														////										
Parshall Flume	7d	8/21/95	8/27/95														////										
Survey Monuments	3d	10/9/95	10/11/95																						////		
Drilling for Foundation piezometers	3d	6/26/95	6/28/95					////																			
TAILINGS ACCESS ROAD AND TAILINGS/RECLAIM PIPELINES	1d	12/29/95	12/29/95																								
MOBILIZATION/DEMOBILIZATION	98d	7/3/95	10/8/95																								
Mobilization	7d	7/3/95	7/9/95							////																	
Demobilization	7d	10/2/95	10/8/95																					////			
TAILINGS ACCESS ROAD	91d	6/26/95	9/24/95																								
Tree Clearing (by Others)	14d	6/26/95	7/9/95					////																			
Stripping, Grubbing and Topsoil windrowing	14d	7/10/95	7/23/95						////																		
Redistribution of Topsoil	7d	9/7/95	9/13/95																			////					
Construct Tailings Access Road	28d	7/17/95	8/13/95							////																	
Pipe Bedding, Wearing Course and Riprap	28d	7/31/95	8/27/95								////																
Supply/install Pipe Arch Culvert	7d	9/18/95	9/24/95																			////					
Construct South Sediment Control Pond Road	10d	8/28/95	9/6/95																			////					

1
 IMPERIAL METALS CORPORATION - MT. POLLEY PROJECT
 STAGE 1b 1995 TAILINGS STORAGE FACILITY CONSTRUCTION SCHEDULE

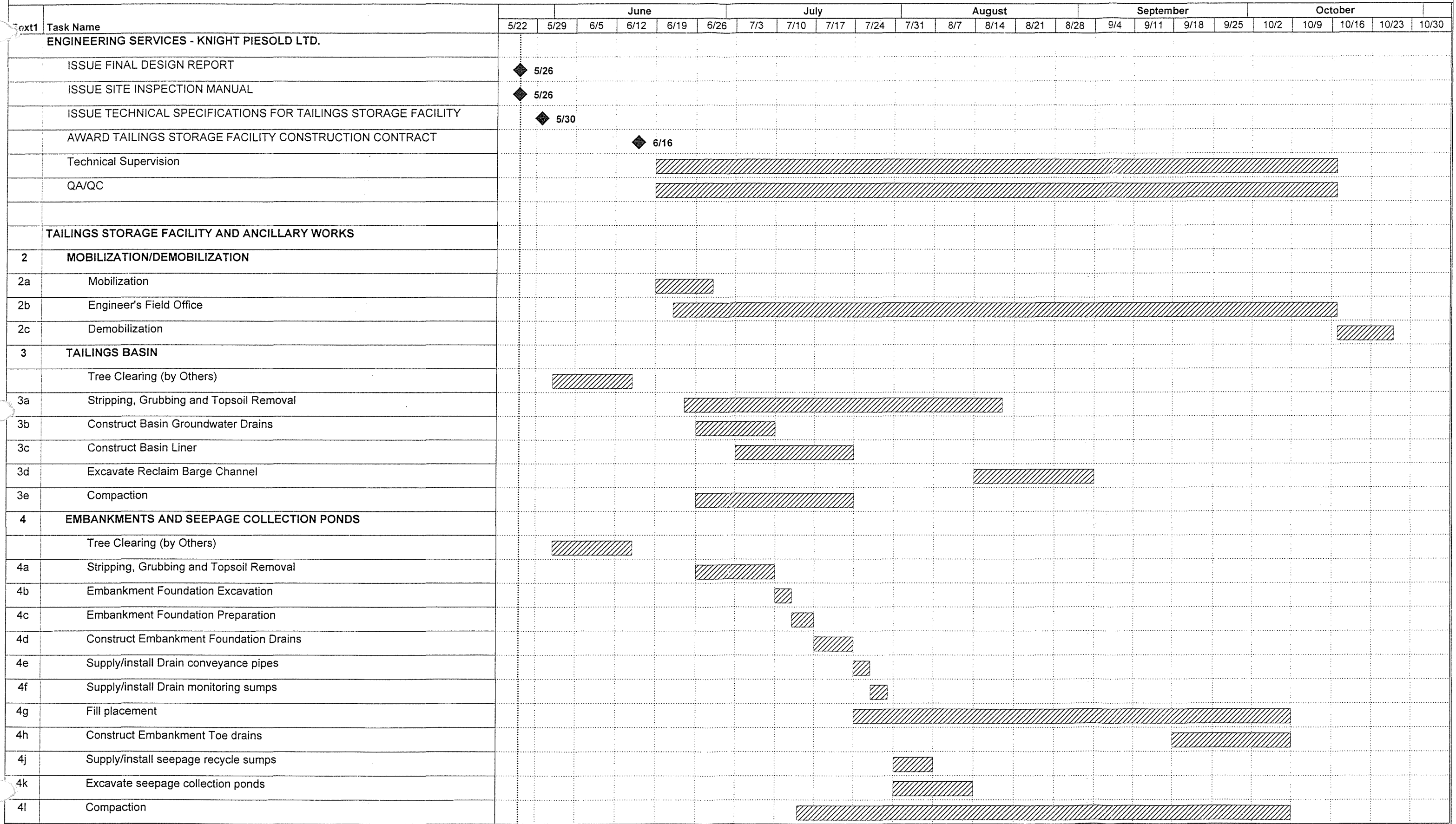

IMPERIAL METALS CORPORATION
MT. POLLEY PROJECT
DEPTH/AREA/CAPACITY/FILLING RATE
FOR TAILINGS STORAGE FACILITY

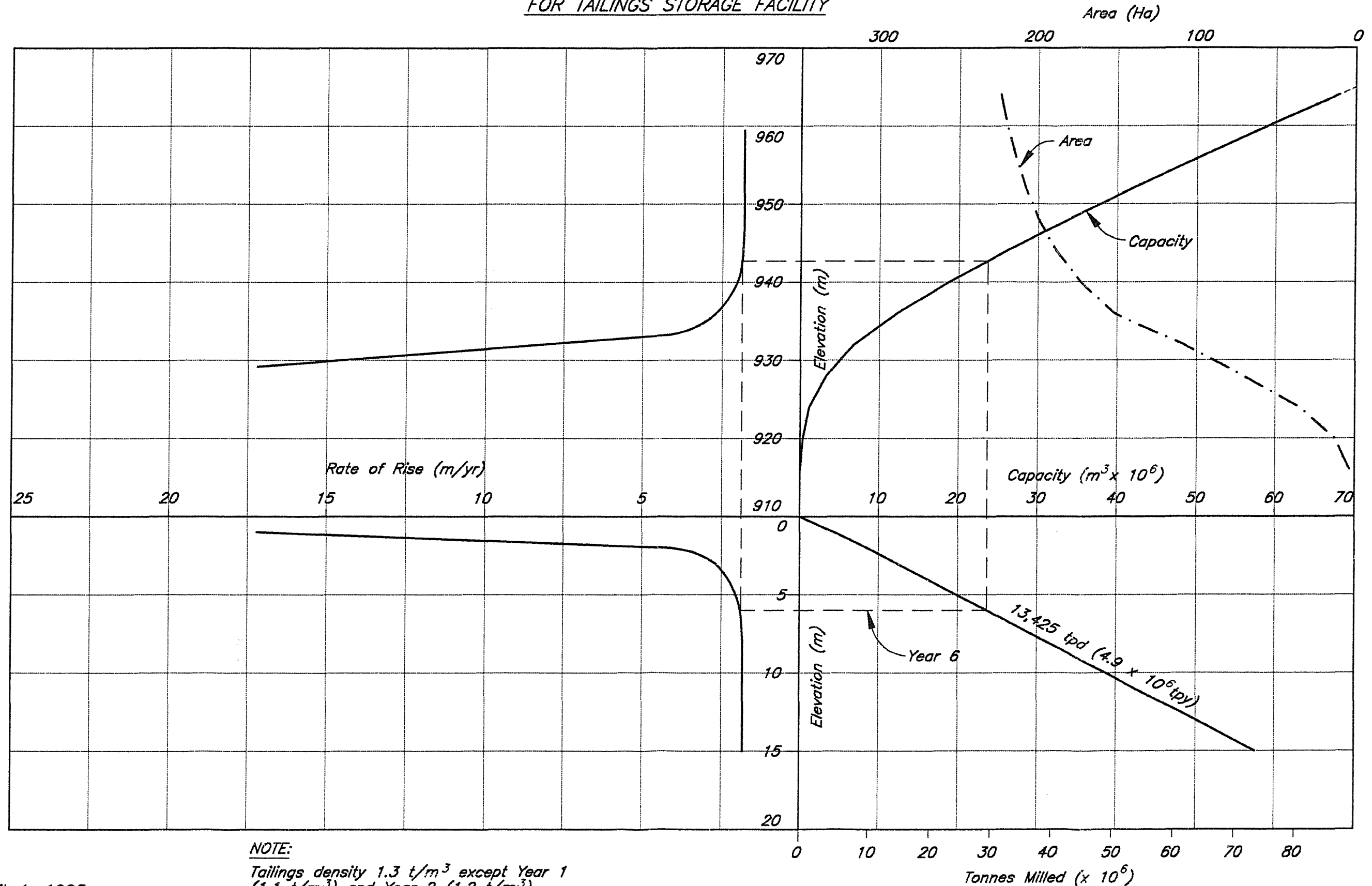

NOTE:
Tailings density 1.3 t/m³ except Year 1
(1.1 t/m³) and Year 2 (1.2 t/m³)

FIGURE 6.2

CAD FILE: [PROJECT] 1625\FR\B1_PRR 1-1

IMPERIAL METALS CORPORATION
MT. POLLEY PROJECT
TAILINGS AREA FILLING SCHEDULE AND STAGED CONSTRUCTION
FOR 4,900,000 tpy THROUGHPUT

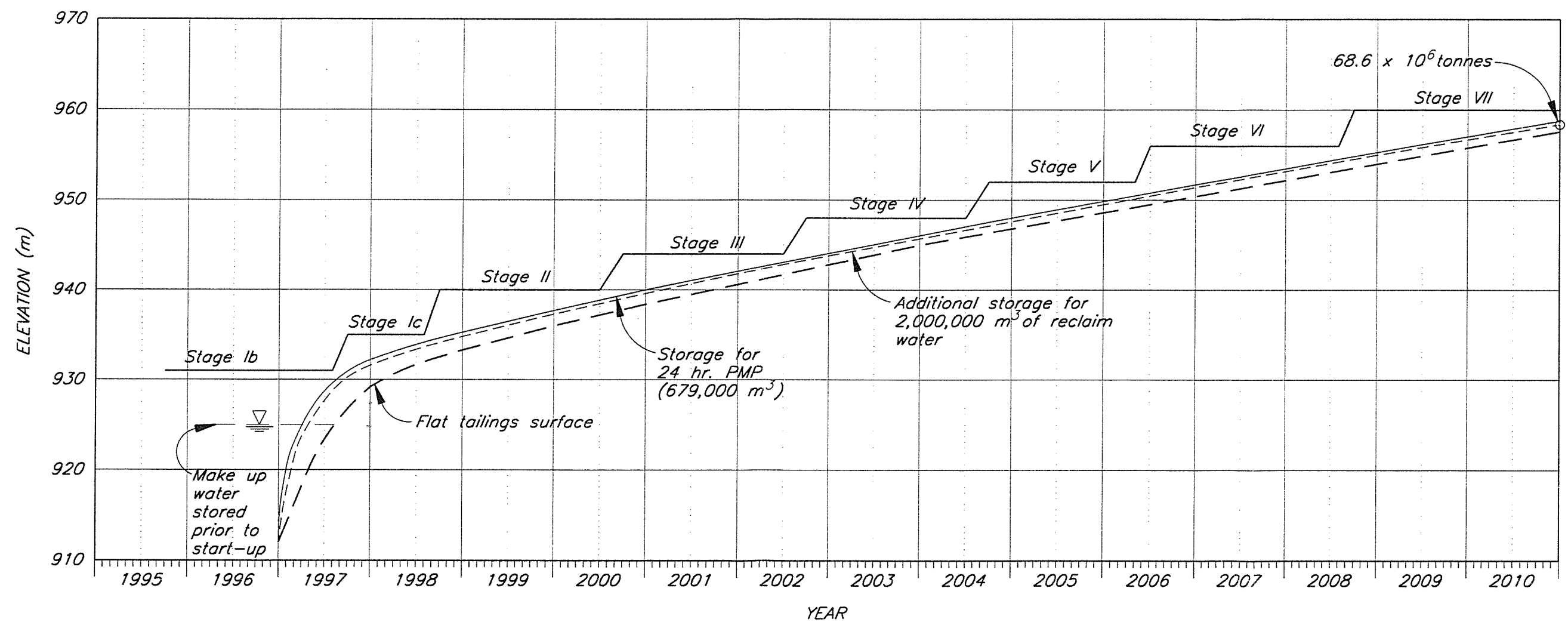

NOTE:

1. All construction periods shown as 3 months, including July, August and September.
2. Embankment raises will be re-evaluated during mine operation to ensure that adequate storage capacity and embankment freeboard are maintained throughout the life of the mine.

CAD FILE: \PROJECT\1625\FIG\B2 Plot 1-1

IMPERIAL METALS CORPORATION
MT. POLLEY PROJECT
SUPERNATANT POND DEPTH/AREA/CAPACITIES
ON 0.5 % SLOPED TAILINGS SURFACE

March 31, 1995
 KNIGHT PIESOLD LTD.
 CONSULTING ENGINEERS

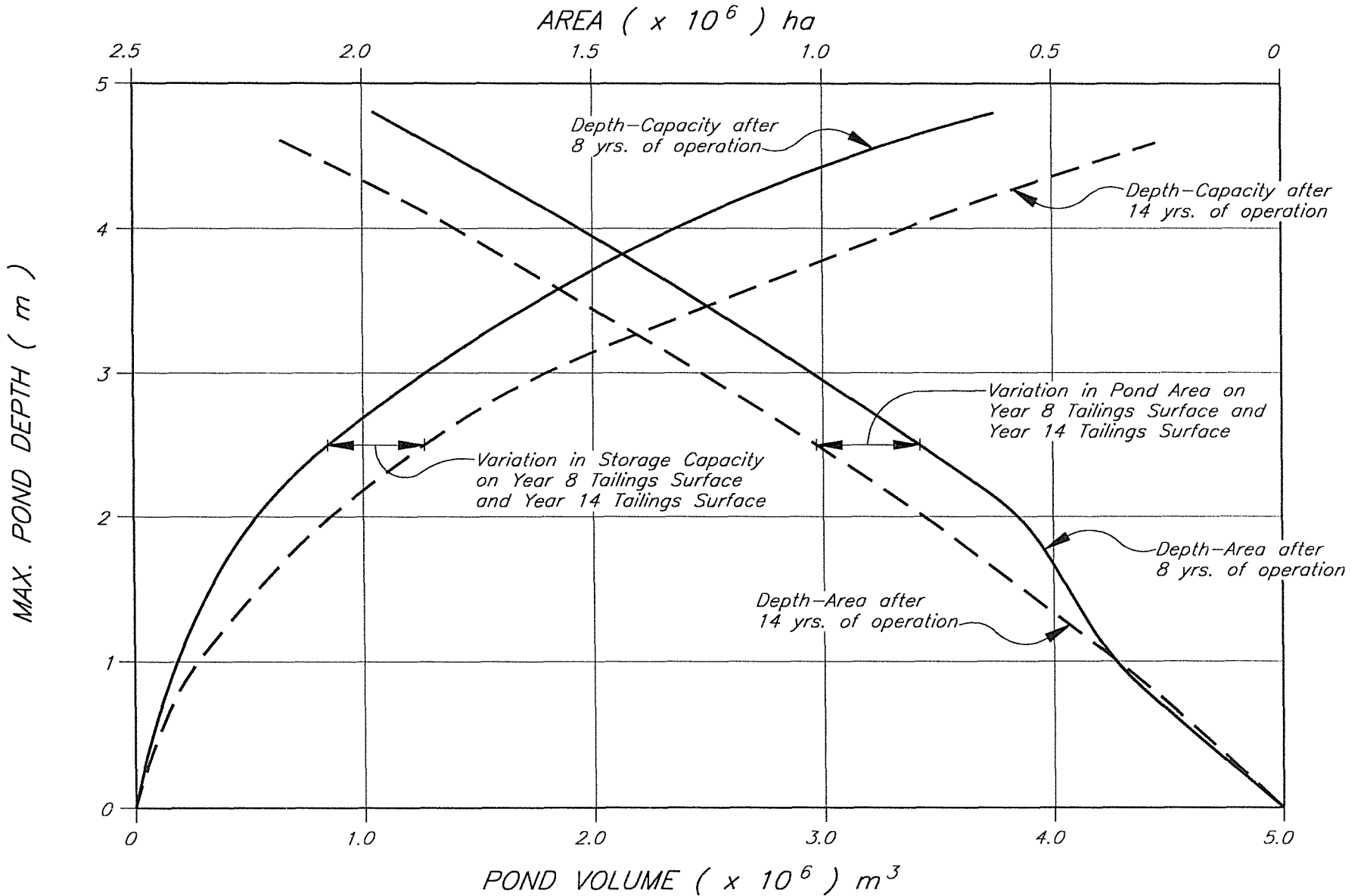
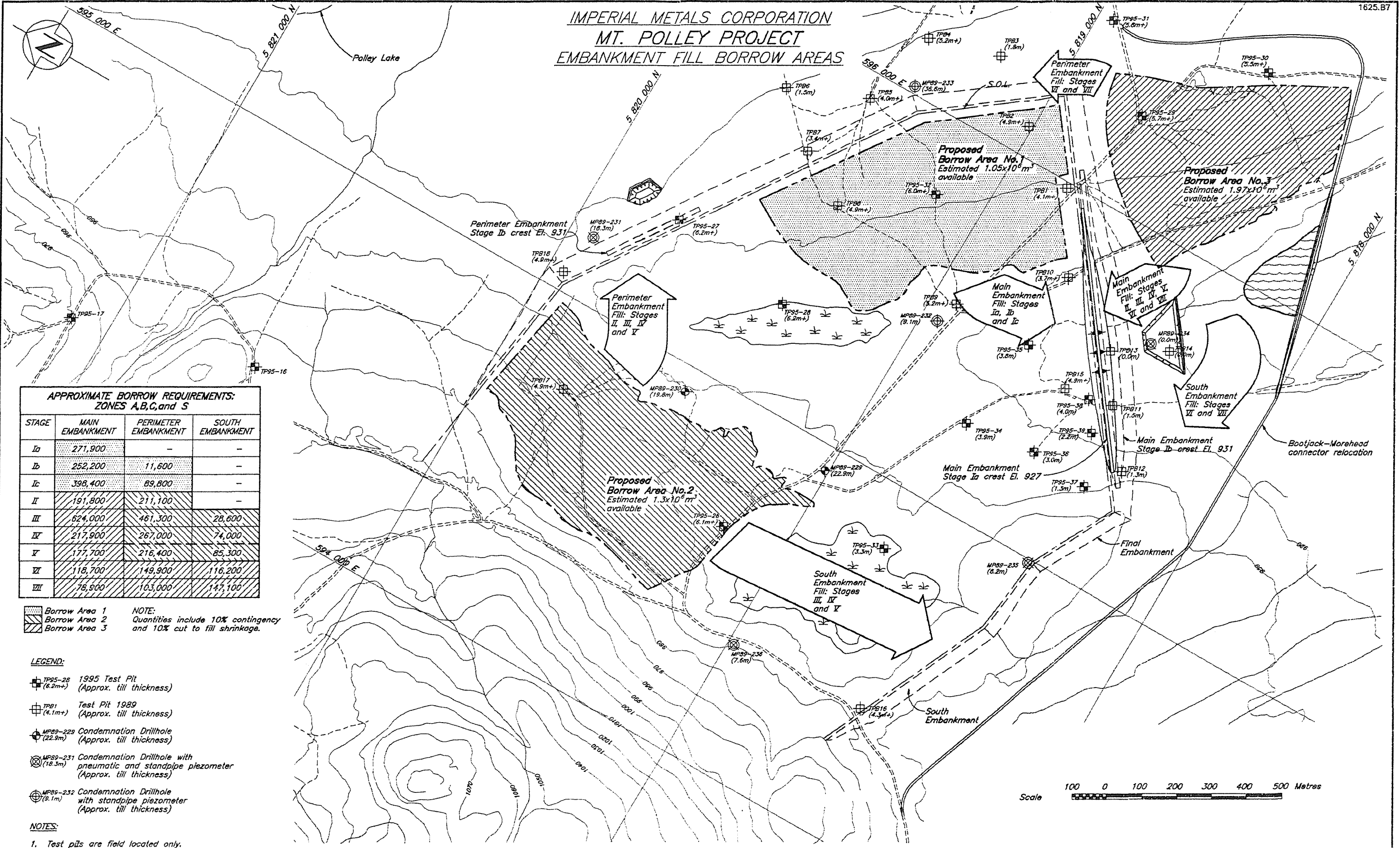

FIGURE 6.4

IMPERIAL METALS CORPORATION
 MT. POLLEY PROJECT
 EMBANKMENT FILL BORROW AREAS

1625.67



**APPROXIMATE BORROW REQUIREMENTS:
 ZONES A,B,C, and S**

STAGE	MAIN EMBANKMENT	PERIMETER EMBANKMENT	SOUTH EMBANKMENT
Ia	271,900	-	-
Ib	252,200	11,600	-
Ic	398,400	89,800	-
II	191,800	211,100	-
III	524,000	461,300	28,600
IV	217,900	267,000	74,000
V	177,700	216,400	85,300
VI	118,700	149,900	116,200
VII	76,800	103,000	147,100

Borrow Area 1
 Borrow Area 2
 Borrow Area 3

NOTE:
 Quantities include 10% contingency and 10% cut to fill shrinkage.

- LEGEND:**
- TP95-28 (6.2m+) 1995 Test Pit (Approx. till thickness)
 - TP91 (4.1m+) Test Pit 1989 (Approx. till thickness)
 - MP89-229 (22.9m) Condemnation Drillhole (Approx. till thickness)
 - MP89-231 (18.3m) Condemnation Drillhole with pneumatic and standpipe piezometer (Approx. till thickness)
 - MP89-232 (9.1m) Condemnation Drillhole with standpipe piezometer (Approx. till thickness)

NOTES:
 1. Test pits are field located only.

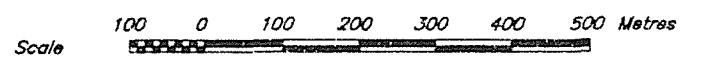

FIGURE 6.5

CAD FILE: \PROJECT\1625\F6\BT Plot scale 1=10 STD. 1

IMPERIAL METALS CORPORATION MT. POLLEY PROJECT EMBANKMENT SETTLEMENT ANALYSES

May 25, 1995
KNIGHT PIESOLD LTD.
CONSULTING ENGINEERS

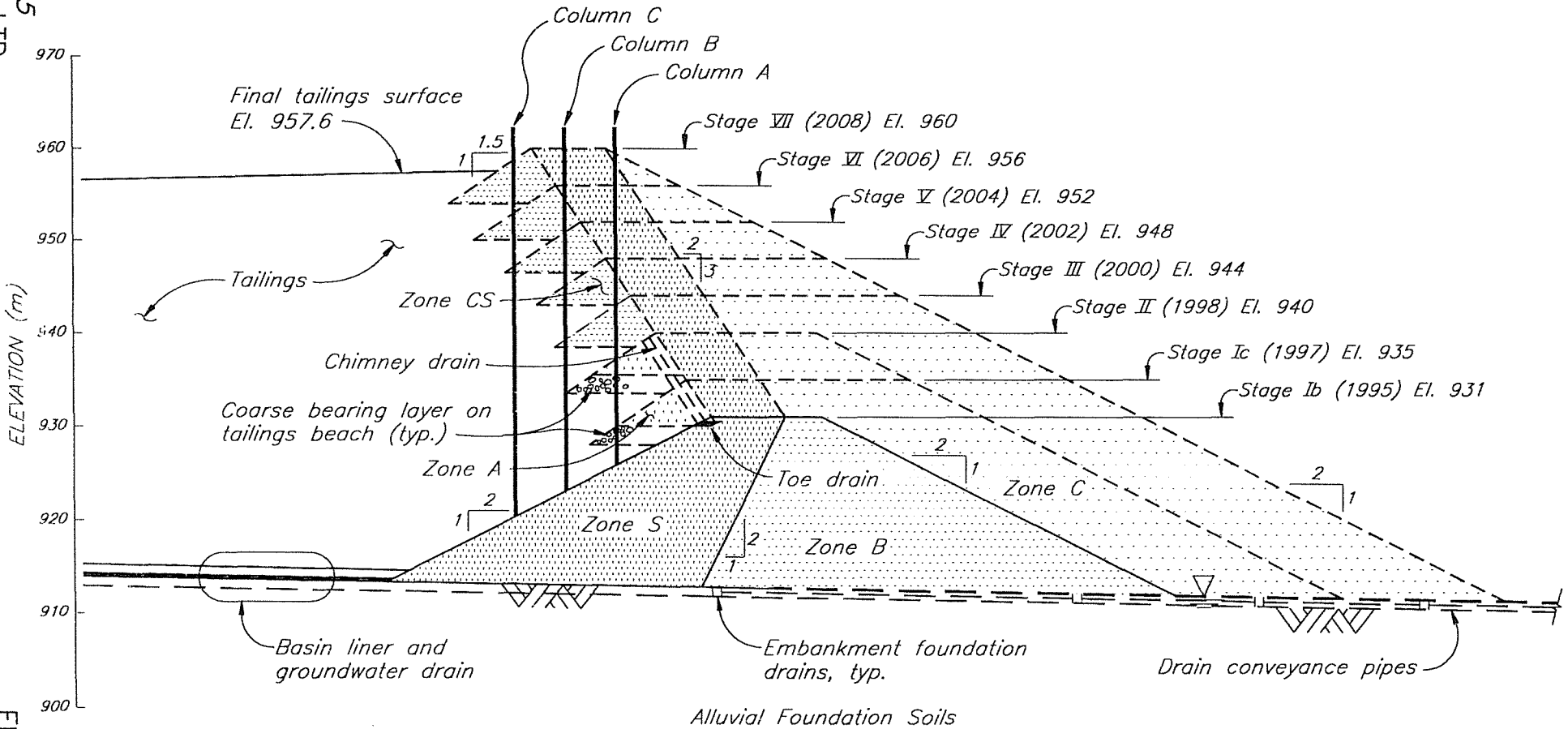
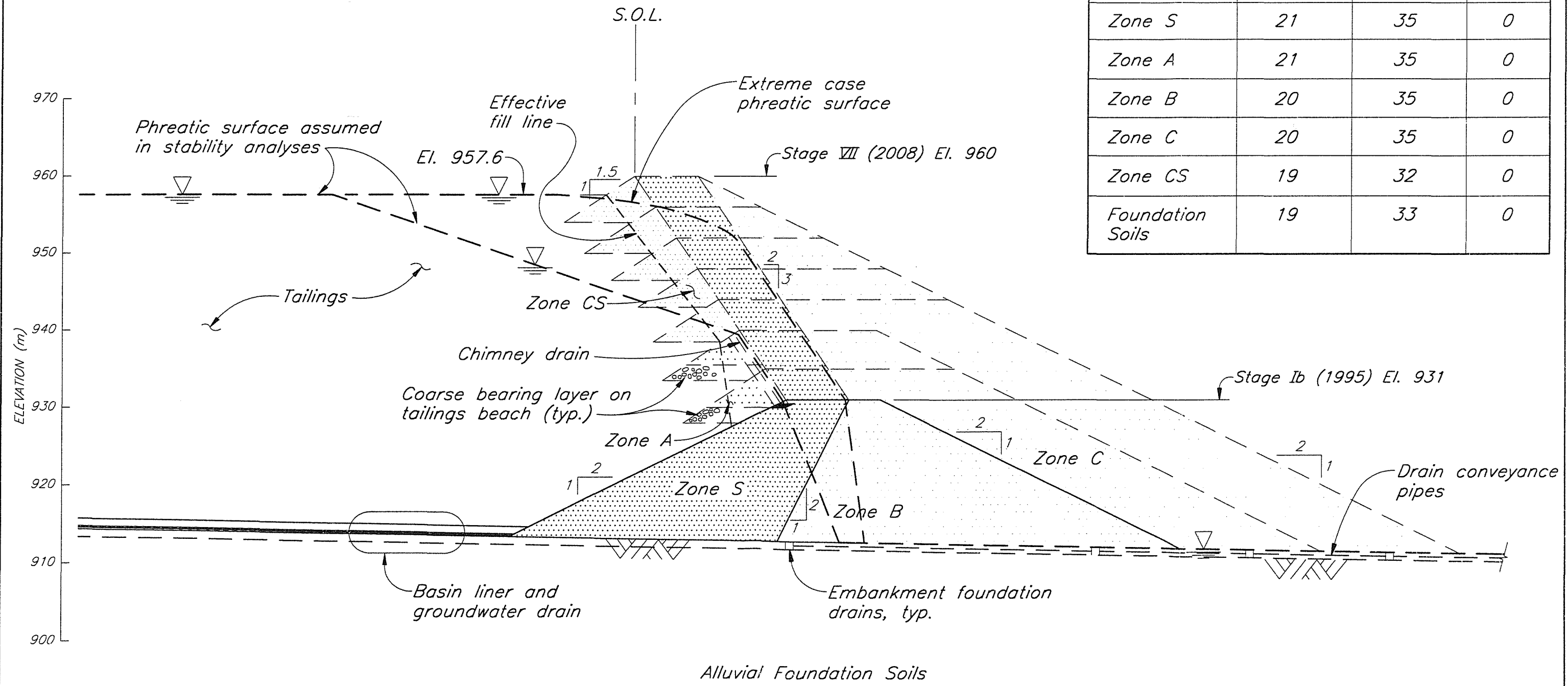

FIGURE 6.6

IMPERIAL METALS CORPORATION
MT. POLLEY PROJECT
EMBANKMENT STABILITY ANALYSES
GEOMETRY AND MATERIAL PARAMETERS

MATERIAL TYPE	UNIT Wt. (kN/m ³)	φ' (degrees)	c _u , c' (kPa)
Partially Consolidated Tailings	18	-	10-55
Consolidated Tailings	19	30	0
Zone S	21	35	0
Zone A	21	35	0
Zone B	20	35	0
Zone C	20	35	0
Zone CS	19	32	0
Foundation Soils	19	33	0



CAD FILE: \PROJECT\1625\FIG\B6_Plot_scale 1=0.5 STD. 1

FIGURE 6.7

IMPERIAL METALS CORPORATION
MT. POLLEY PROJECT
STATIC STABILITY AT CLOSURE

CAD FILE: [PROJECT] 1625\FG\A10 Plot scale 1=1

Potential slip surface
Factor of Safety = 1.43

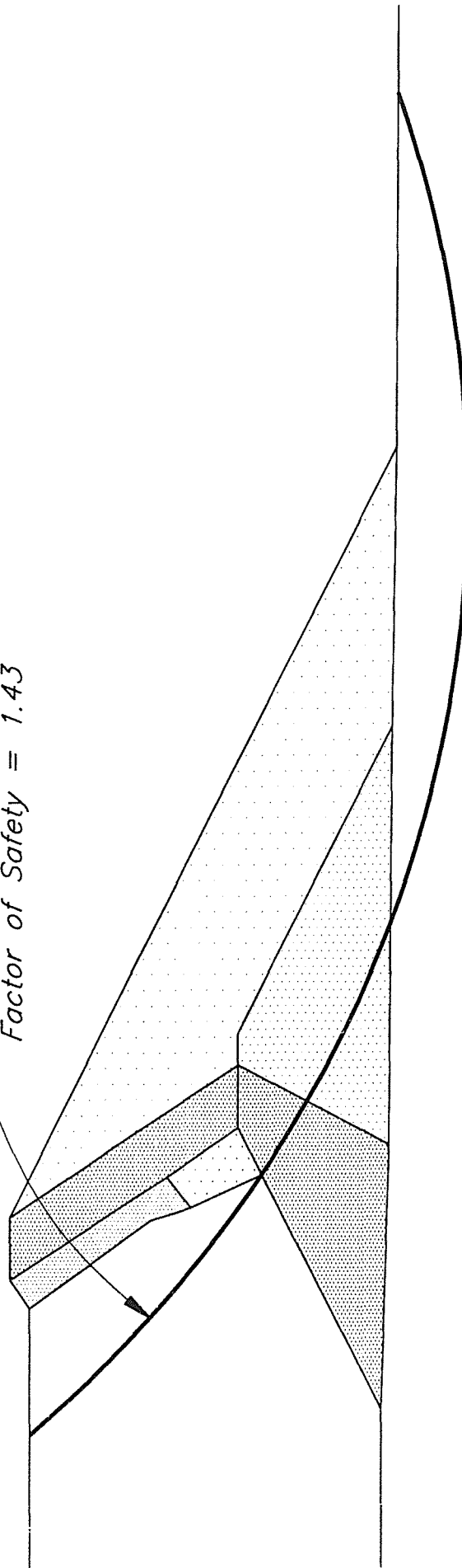

May 24, 1995
KNIGHT PIESOLD LTD.
CONSULTING ENGINEERS

FIGURE 6.8

CAD FILE: [PROJECT]1625\FIG\A11 Plot scale: 1=1

IMPERIAL METALS CORPORATION
MT. POLLEY PROJECT
STATIC STABILITY AFTER CLOSURE

Potential slip surface
Factor of Safety = 1.5

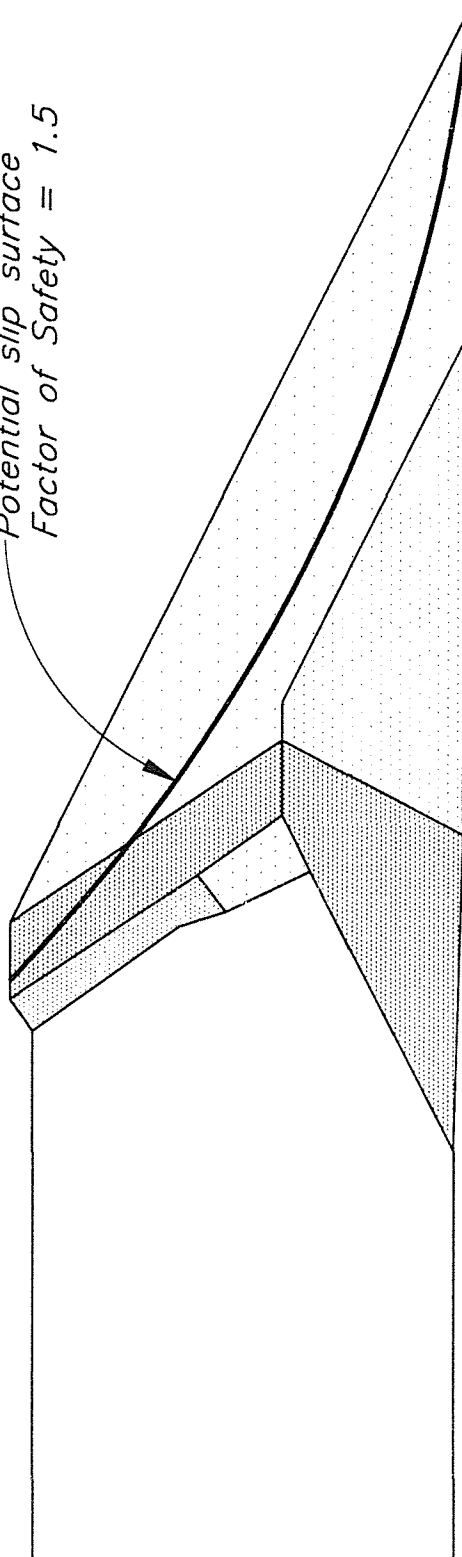

May 24, 1995
KNIGHT PIESOLD LTD.

FIGURE 6.9

IMPERIAL METALS CORPORATION
MT. POLLEY PROJECT
PSEUDOSTATIC STABILITY DURING OPERATIONS

May 24, 1995
KNIGHT PIESOLD LTD.

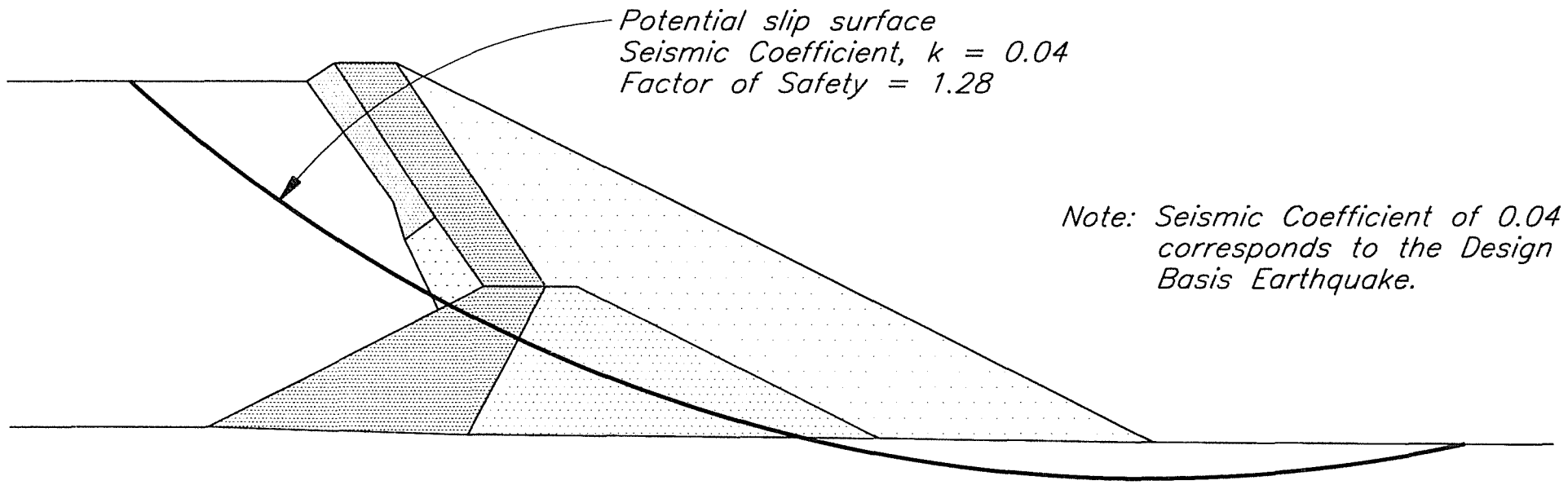
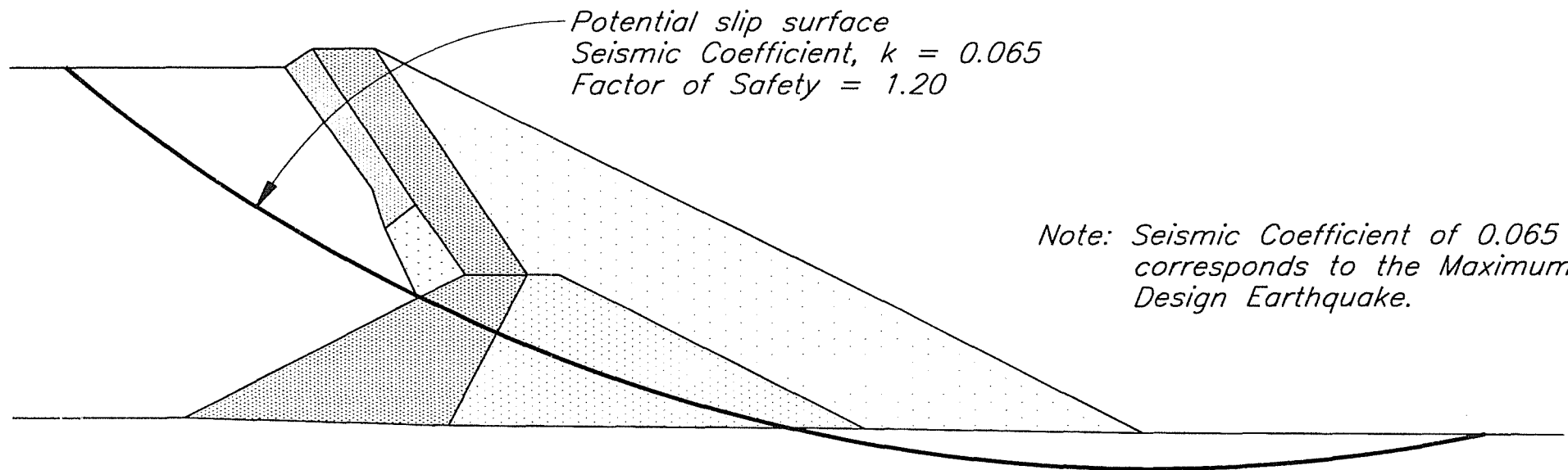

FIGURE 6.10

IMPERIAL METALS CORPORATION
MT. POLLEY PROJECT
PSEUDOSTATIC STABILITY AFTER CLOSURE

May 24, 1995
KNIGHT PIESOLD LTD.



Note: Seismic Coefficient of 0.065 corresponds to the Maximum Design Earthquake.

FIGURE 6.11

IMPERIAL METALS CORPORATION
MT. POLLEY PROJECT
UNDRAINED RESIDUAL STRENGTH STABILITY

Potential slip surface
Factor of Safety = 1.39

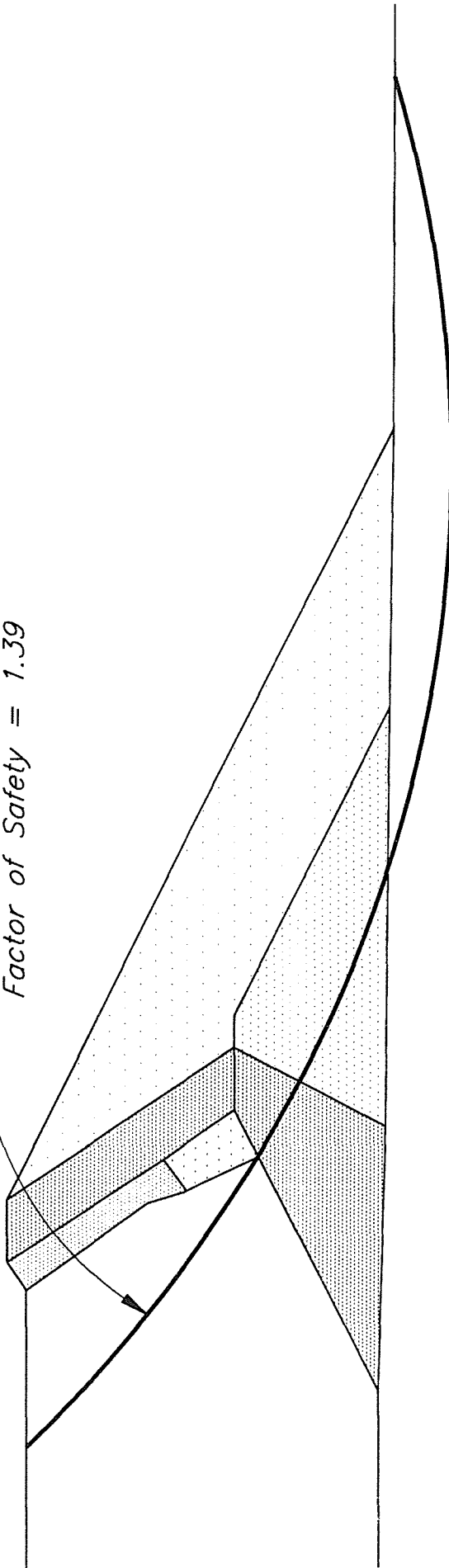

IMPERIAL METALS CORPORATION
MT. POLLEY PROJECT
EMBANKMENT STABILITY SENSITIVITY ANALYSES

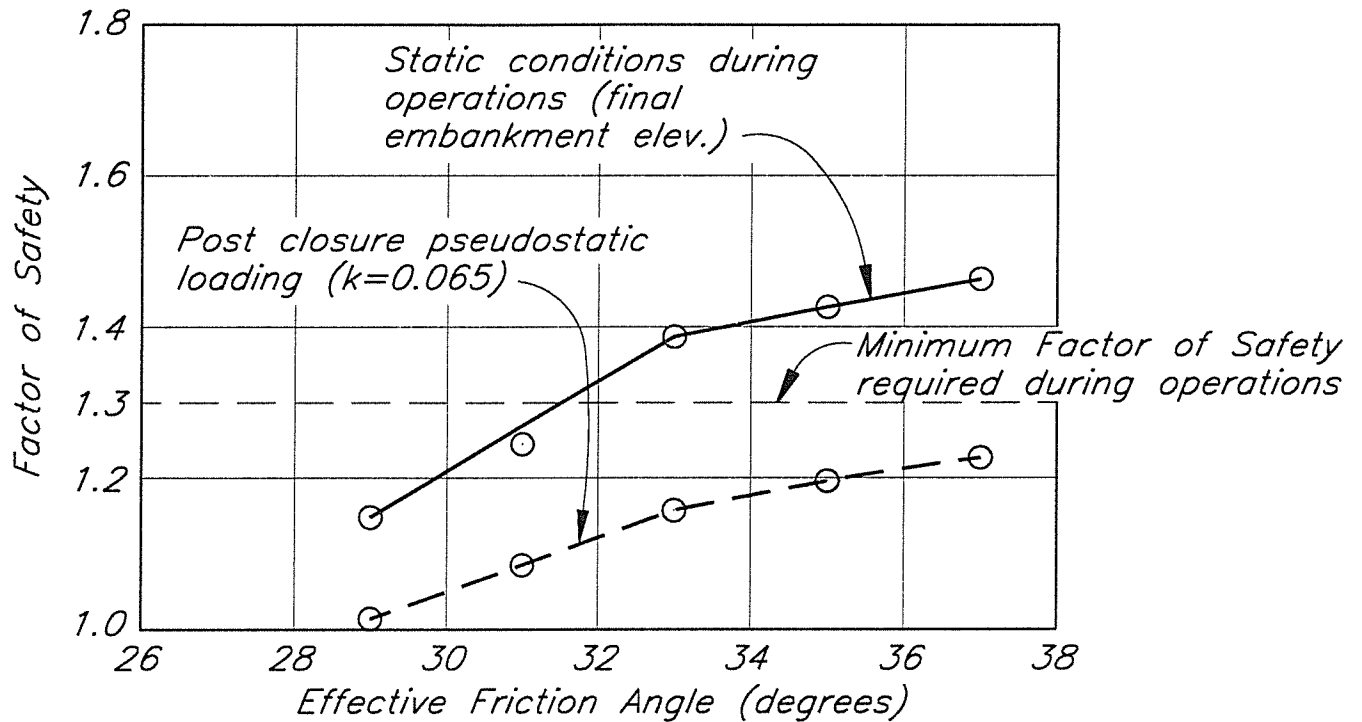

FACTOR OF SAFETY VERSUS EFFECTIVE FRICTION ANGLE OF EMBANKMENT FILL

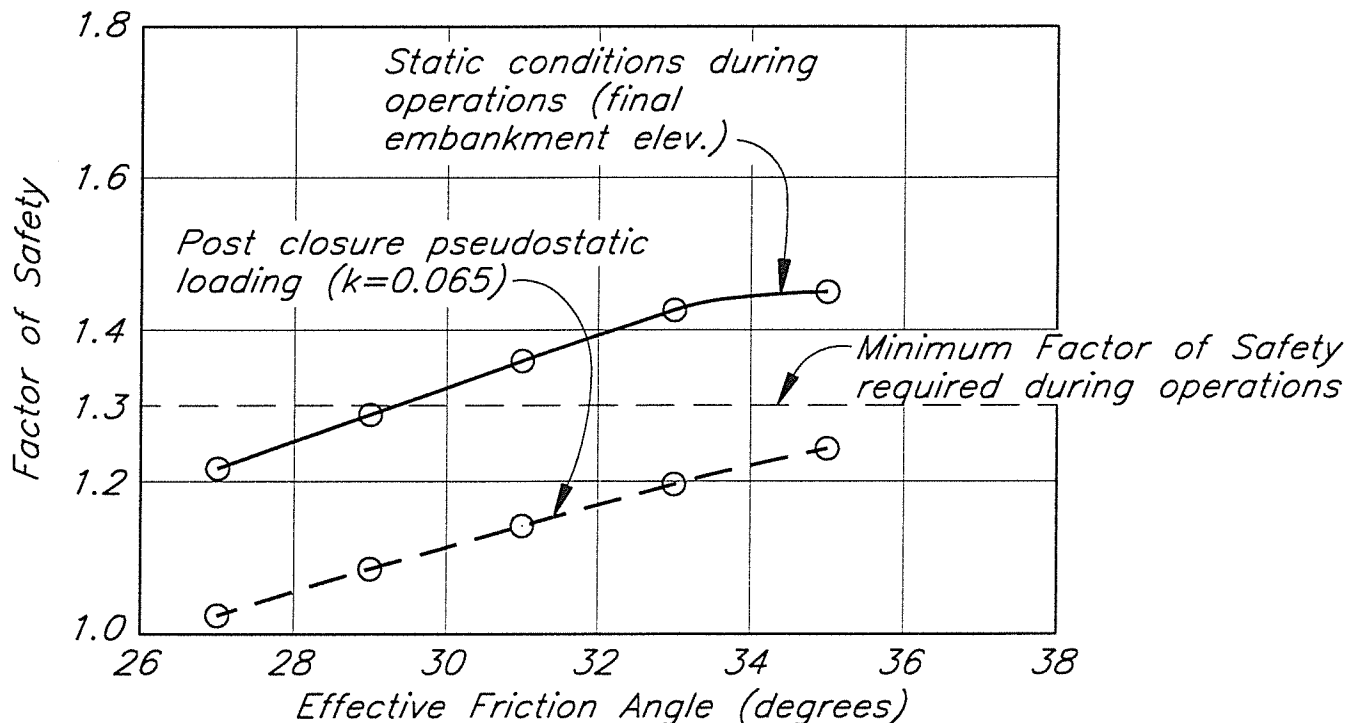

FACTOR OF SAFETY VERSUS EFFECTIVE FRICTION ANGLE OF FOUNDATION SOILS

CAD FILE: [PROJECT]1625\FIG\A18 Plot scale 1=1

IMPERIAL METALS CORPORATION
MT. POLLEY PROJECT
UPSTREAM EMBANKMENT STABILITY ANALYSES

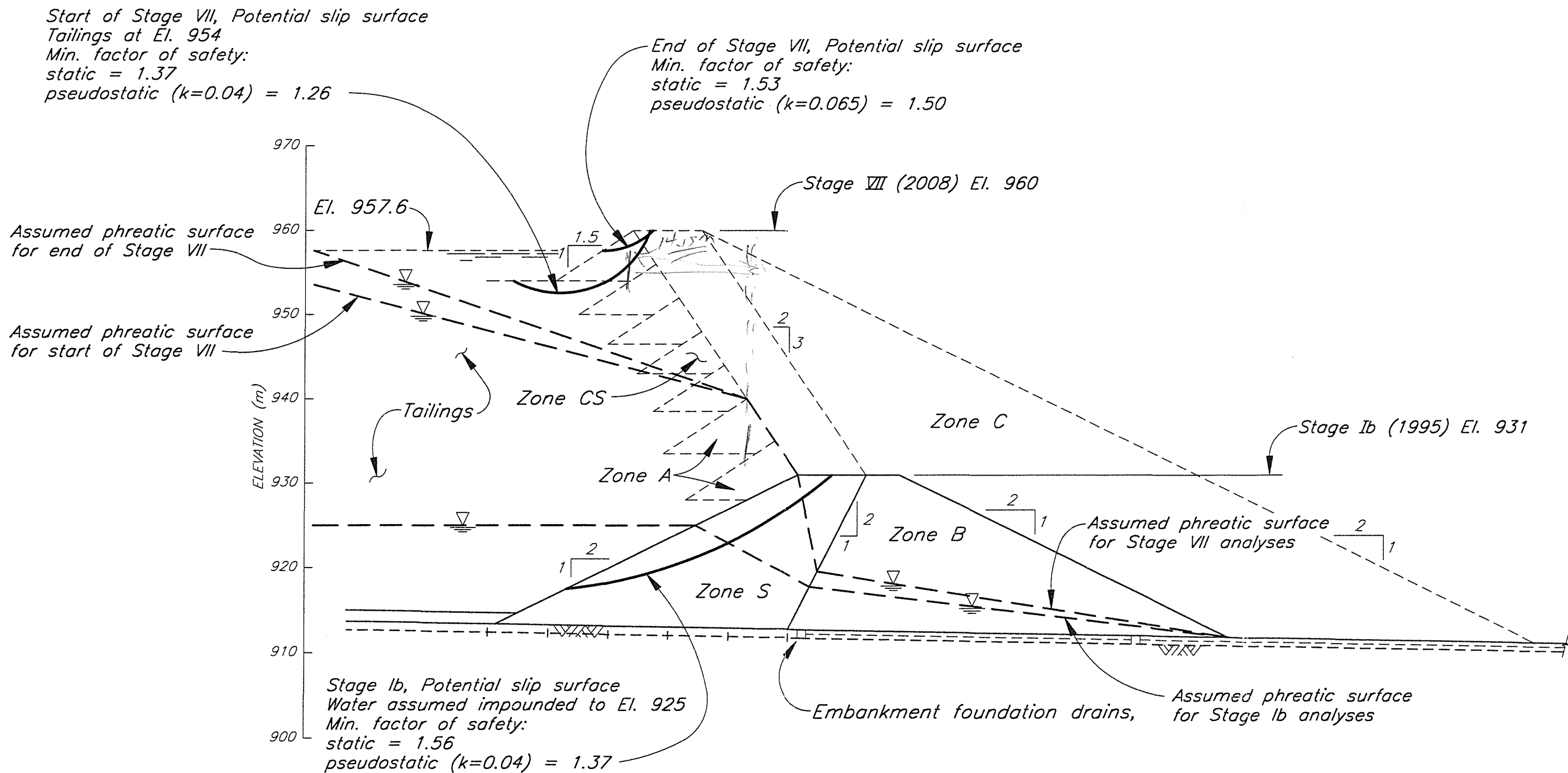

CAD FILE: \PROJECT\1625\FIG\B14 Plot scale 1=1 STD. 1

IMPERIAL METALS CORPORATION
MT. POLLEY PROJECT
SEEPAGE ANALYSIS CROSS-SECTIONS

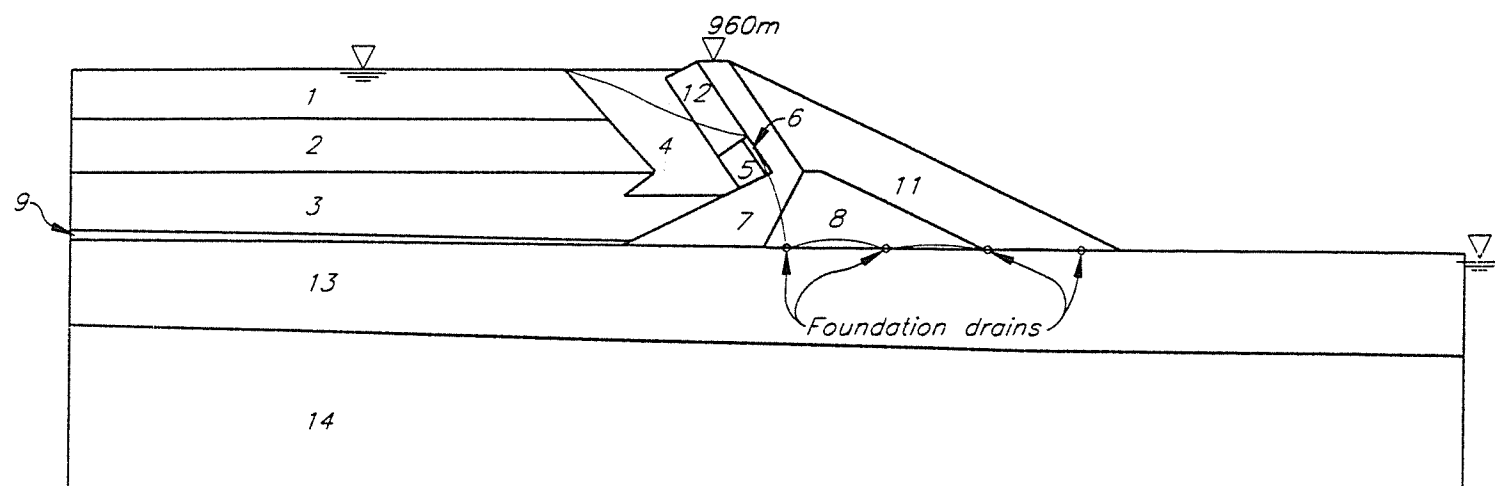

A. Main Embankment

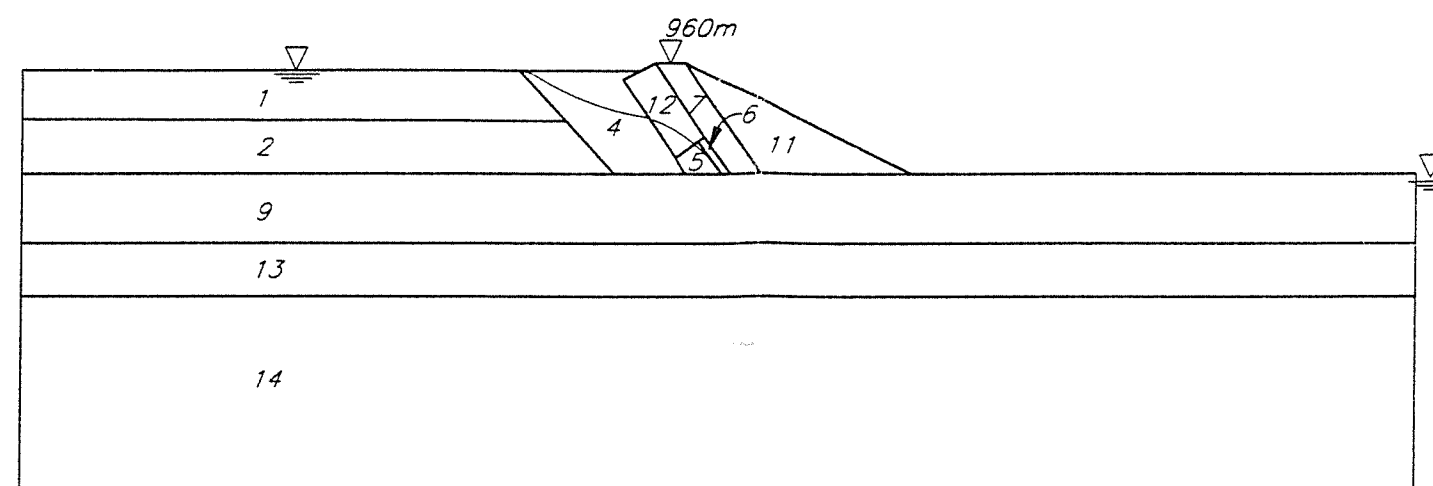

B. Perimeter Embankment

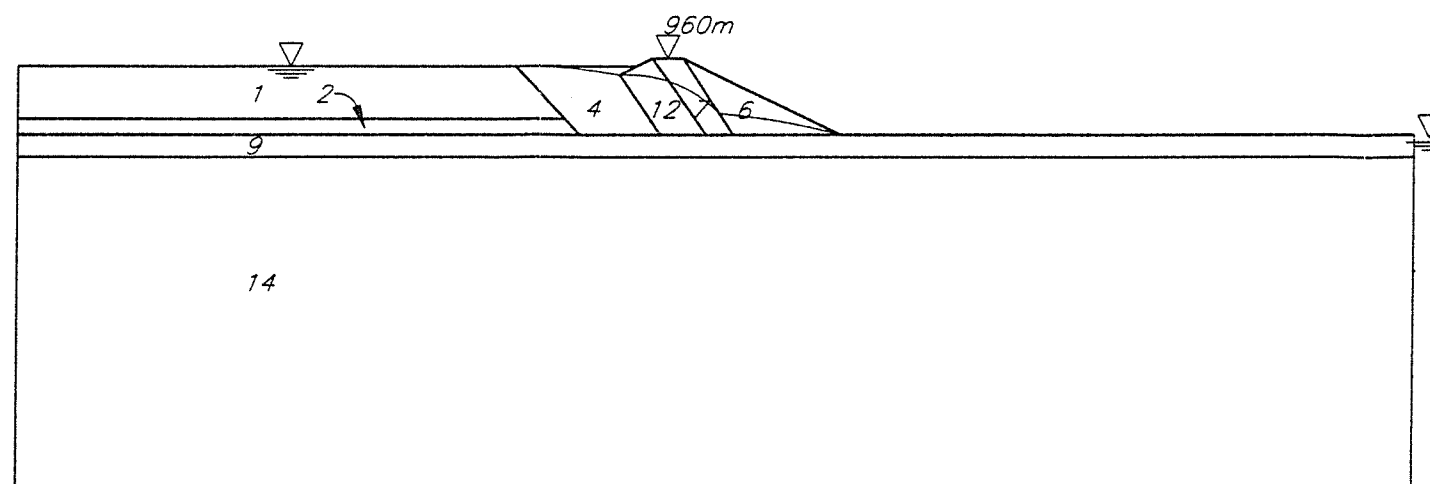

C. South Embankment

IMPERIAL METALS CORPORATION
MT. POLLEY PROJECT
SEEPAGE FLOW DEVELOPMENT
MAIN EMBANKMENT

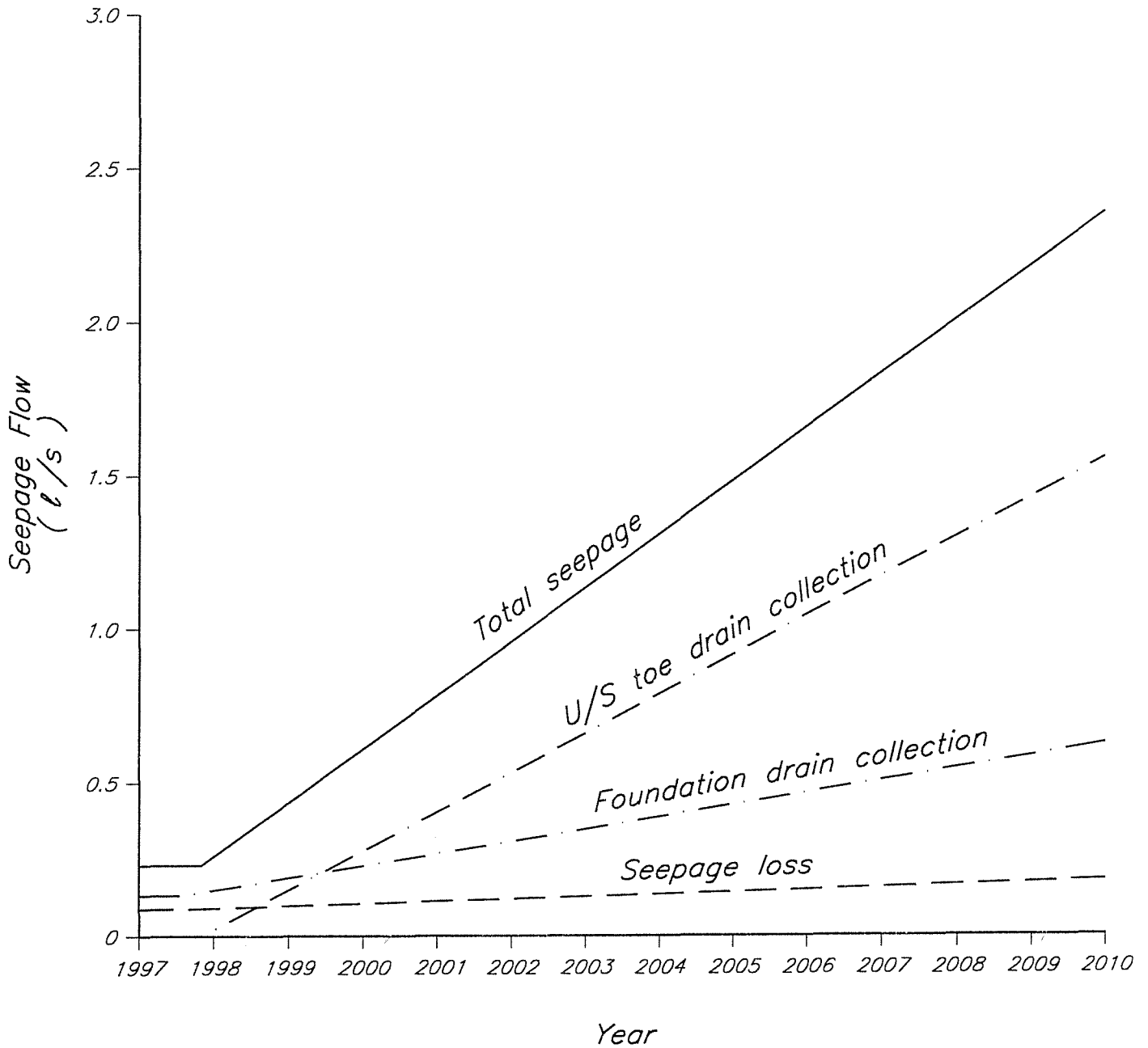

CAD FILE: \PROJECT\1625\FIC\A6 Plot scale 1=1

IMPERIAL METALS CORPORATION
MT. POLLEY PROJECT
SEEPAGE FLOW DEVELOPMENT
PERIMETER EMBANKMENT

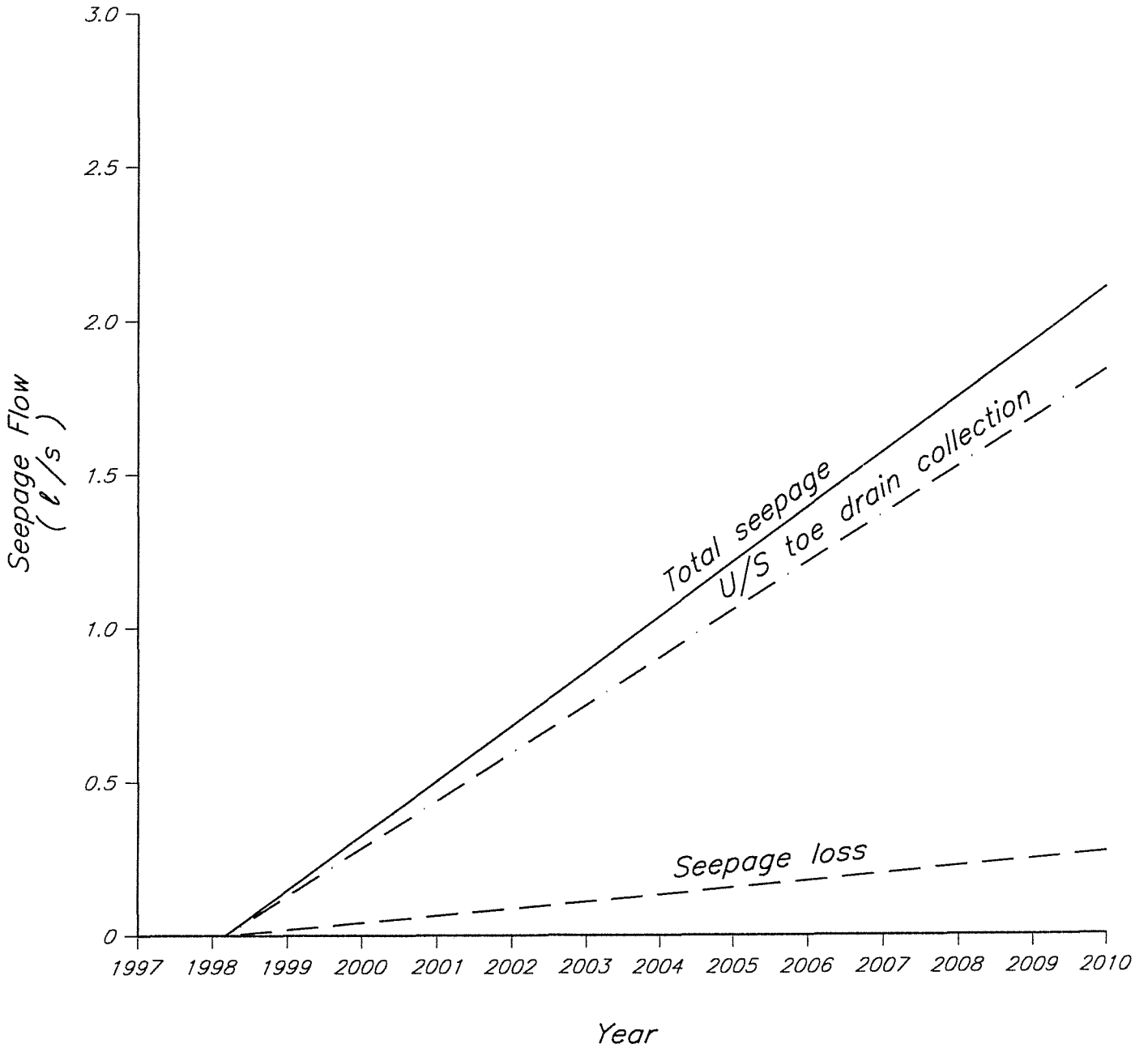

CAD FILE: \PROJECT\1625\FIG\A7 Plot scale 1=1

IMPERIAL METALS CORPORATION
MT. POLLEY PROJECT
SEEPAGE FLOW DEVELOPMENT
SOUTH EMBANKMENT

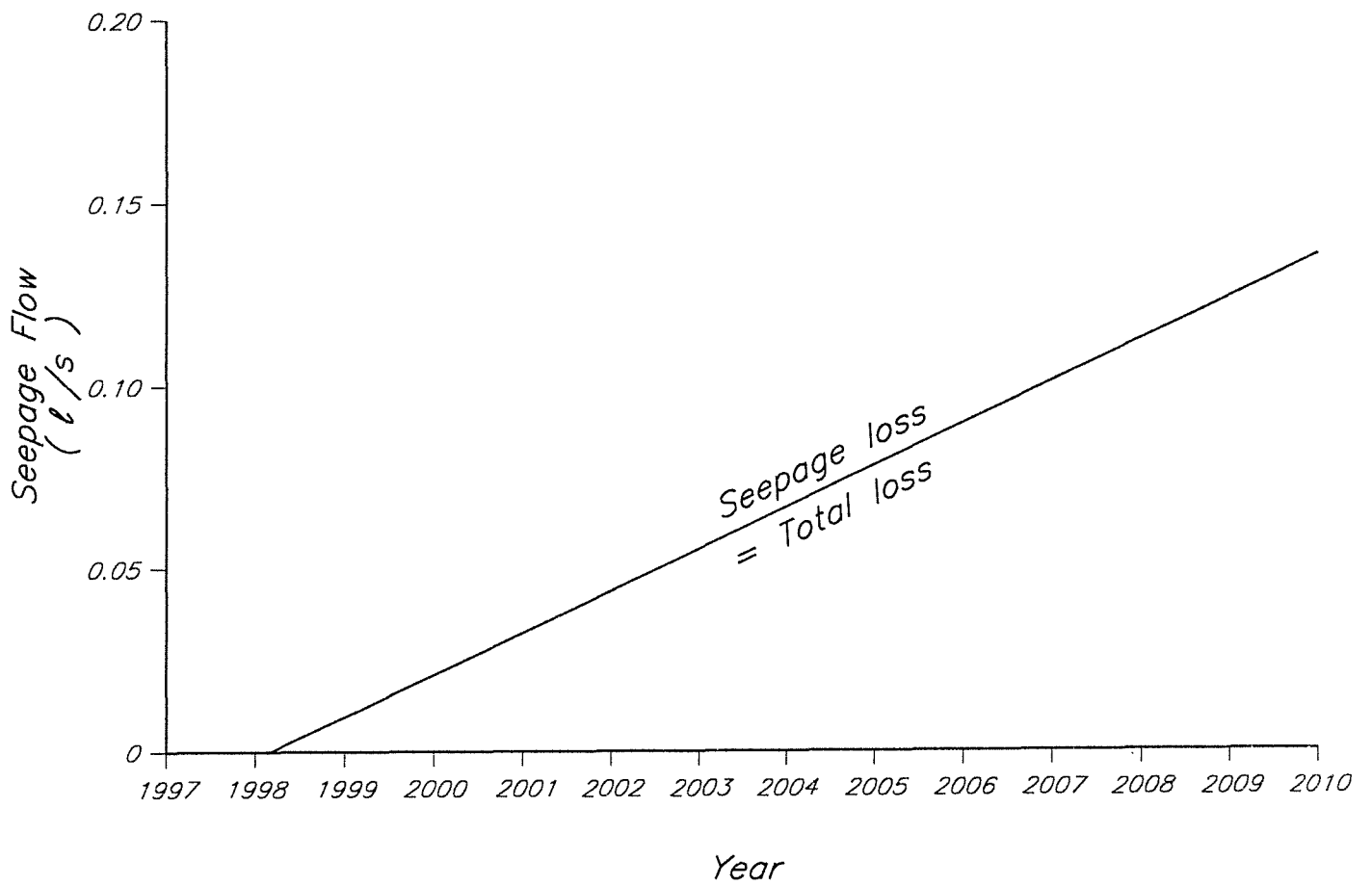

CAD FILE: [PROJECT] 1625\FIC\A8 Plot scale 1=1

IMPERIAL METALS CORPORATION MT. POLLEY PROJECT SITE WATER MANAGEMENT SCHEMATIC

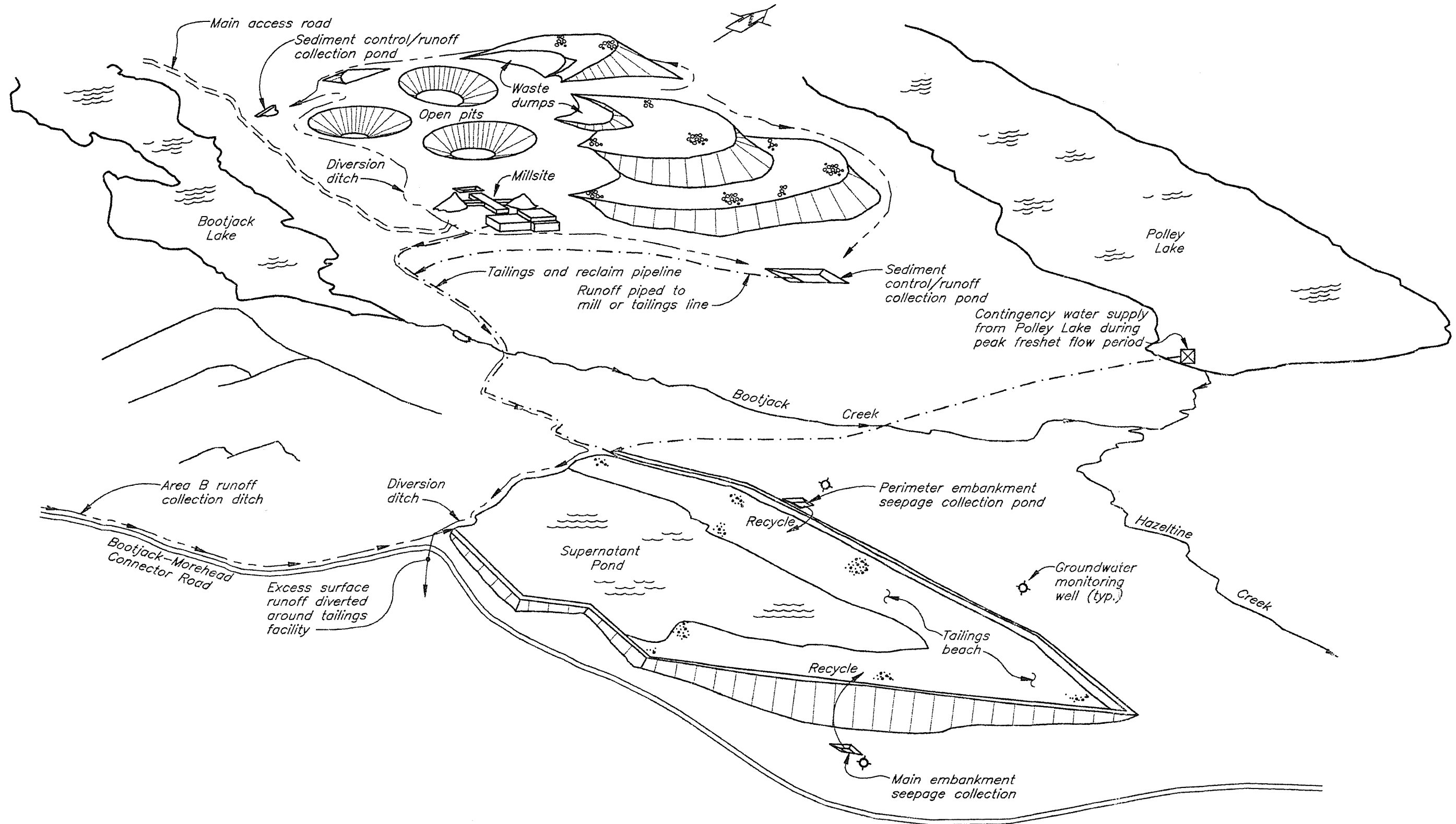

CAD FILE: \PROJECT\1625\161.B4 Plot scale 1=2 STD. 1

**IMPERIAL METALS CORPORATION
MT. POLLEY PROJECT
TAILINGS STORAGE FACILITY
ANNUAL WATER BALANCE SCHEMATIC – AVERAGE YEAR – YEAR 1**

March 22, 1995
KNIGHT PIESOLD LTD.
CONSULTING ENGINEERS

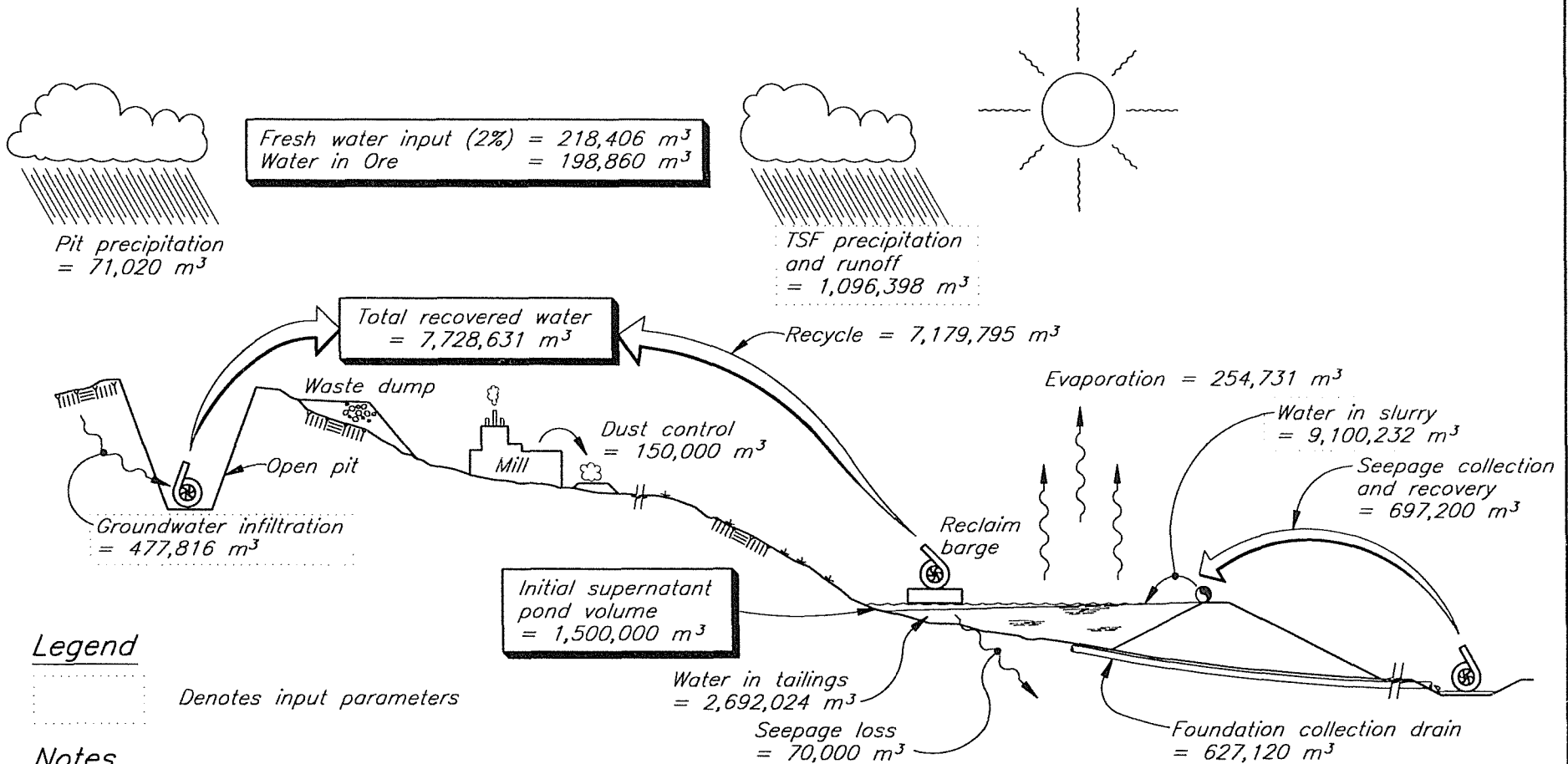

Legend

 Denotes input parameters

Notes

1. Total precip. = 1,096,398 m³
 2. Water in slurry = 9,100,232 m³ } 10,196,630 m³

1. Seepage = 70,080 m³
 2. Evaporation = 254,731 m³
 3. Water in tailings = 2,692,024 m³ } 3,016,835 m³

1. From tailings = Total in - unrecovered in tailings = 6,408,208 m³
 2. Net precip. = Total precip. - evap. - seepage - found. collection = 144,467 m³
 3. Found. collection = 627,120 m³ } 7,179,795 m³ } 10,196,630 m³

FIGURE 8.2

IMPERIAL METALS CORPORATION
MT. POLLEY PROJECT
TAILINGS STORAGE FACILITY
ANNUAL WATER BALANCE SCHEMATIC - AVERAGE YEAR - YEAR 14

March 22, 1995
 KNIGHT PIESOLD LTD.
 CONSULTING ENGINEERS

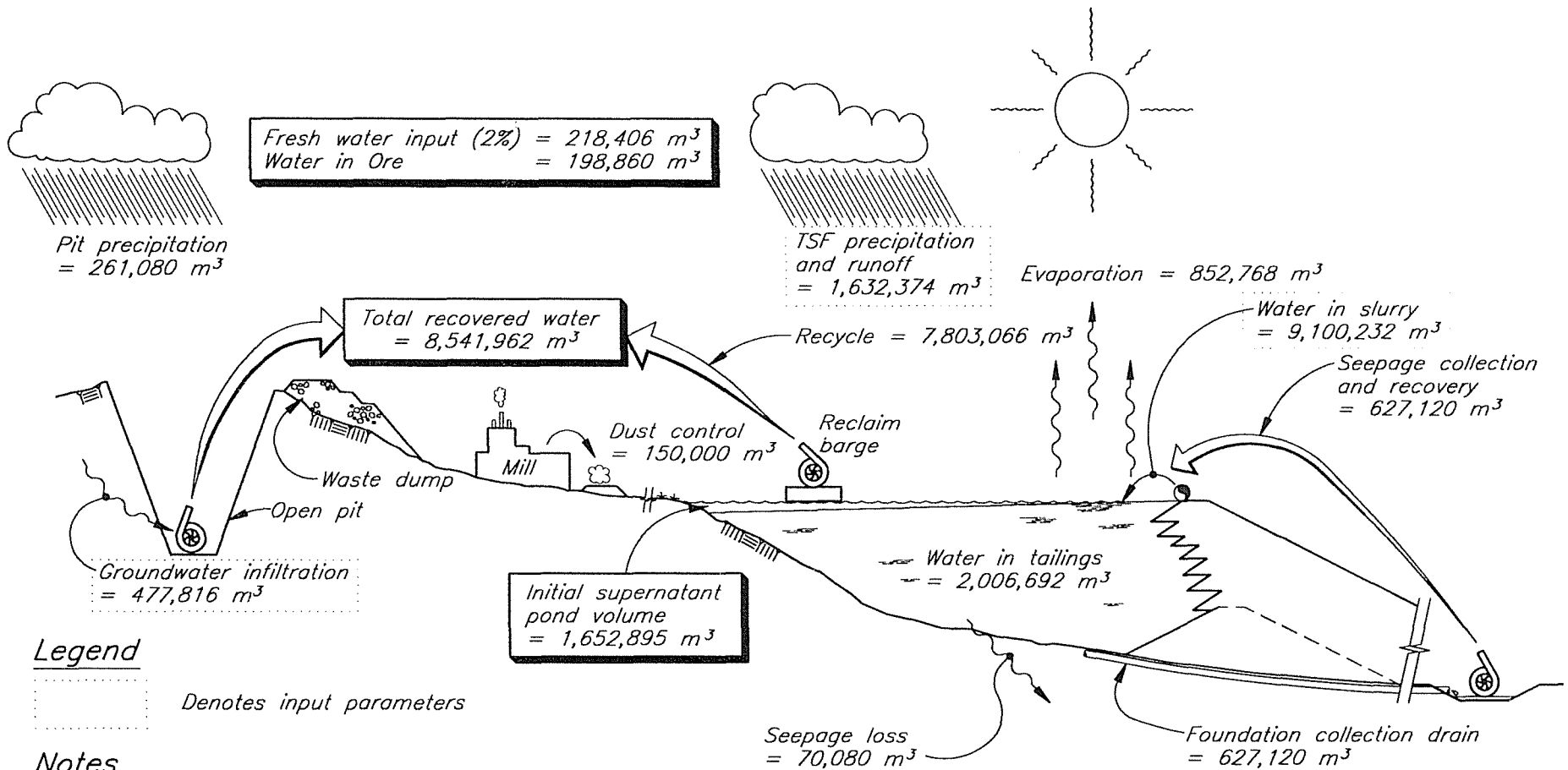

Legend

Denotes input parameters

Notes

1. Total precip. = 1,632,374 m³
 2. Water in slurry = 9,100,232 m³ } 10,732,606 m³

1. Seepage = 70,080 m³
 2. Evaporation = 852,768 m³
 3. Water in tailings = 2,006,692 m³ } 2,929,540 m³

1. From tailings = Total in - unrecovered in tailings = 7,093,540 m³
 2. Net precip. = Total precip. - evap. - seepage - found. collection = 82,406 m³
 3. Found. collection = 627,120 m³ } 7,803,066 m³ } 10,732,606 m³

FIGURE 8.3

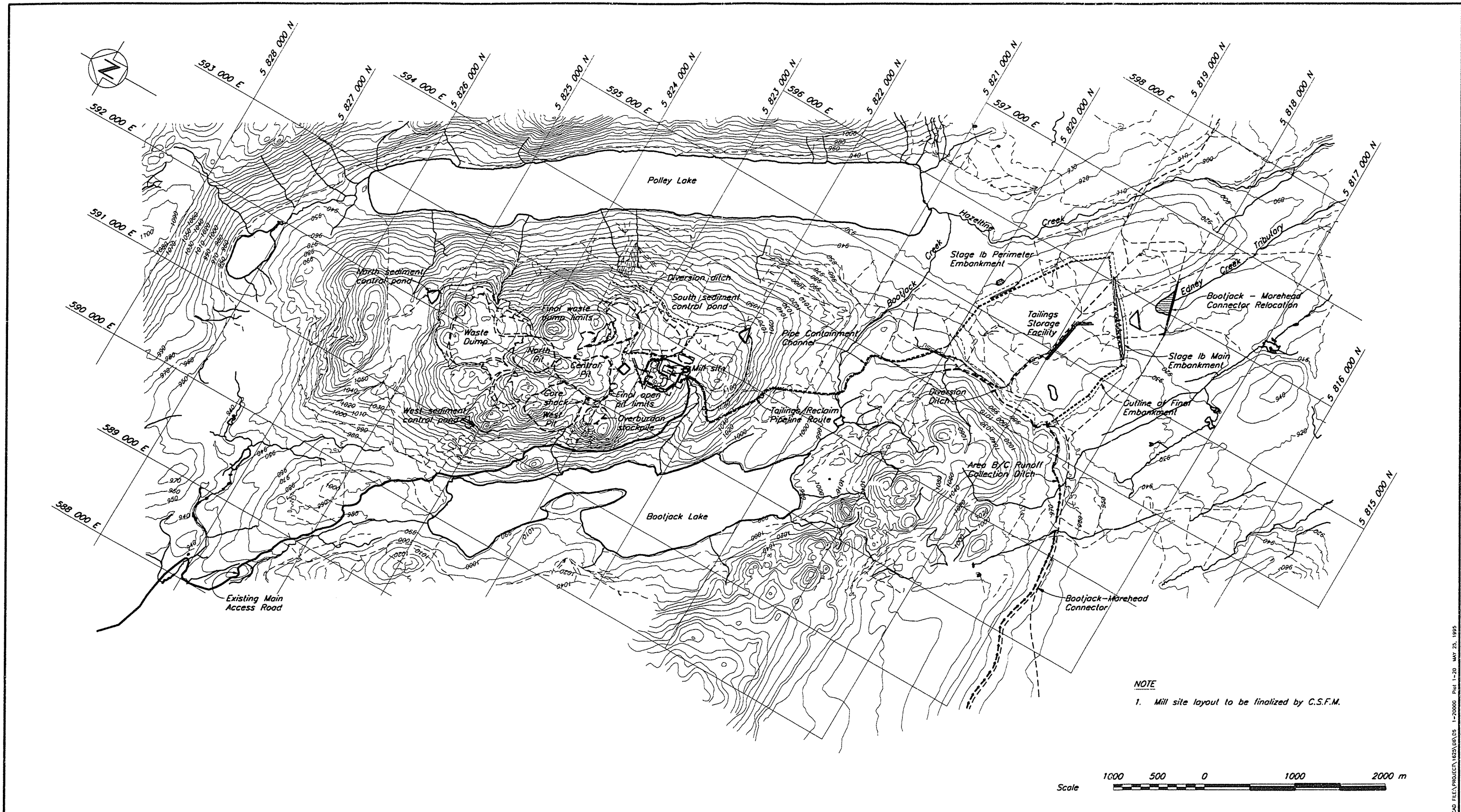

NOTE
 1. Mill site layout to be finalized by C.S.F.M.



DRG. NO.	DESCRIPTION	REV.	DATE	DESCRIPTION	APPROVED
	REFERENCE DRAWINGS			REVISIONS	

REV.	DATE	DESCRIPTION	APPROVED
1	MAY 26/95	ISSUED FOR DESIGN REPORT	KJS
0	A.P.R. 6/95	ISSUED FOR REVIEW	

KNIGHT PIESOLD LIMITED
 CONSULTING ENGINEERS - VANCOUVER, B.C.

DESIGNED KDE/KGB
 DRAWN RDT
 CHECKED [Signature]
 APPROVED [Signature]

K. D. K. EMBREE
 BRITISH COLUMBIA ENGINEER

DATE **APRIL 6, 1995**

IMPERIAL METALS CORPORATION

MT. POLLEY PROJECT

TAILINGS STORAGE FACILITY OVERALL SITE PLAN

SCALE AS SHOWN

DRG. NO. **1625.100**

REV. **1**

CAD FILE: PROJECT\1625\1625.DWG 1-200000 Plot 1-20 MAY 25, 1995

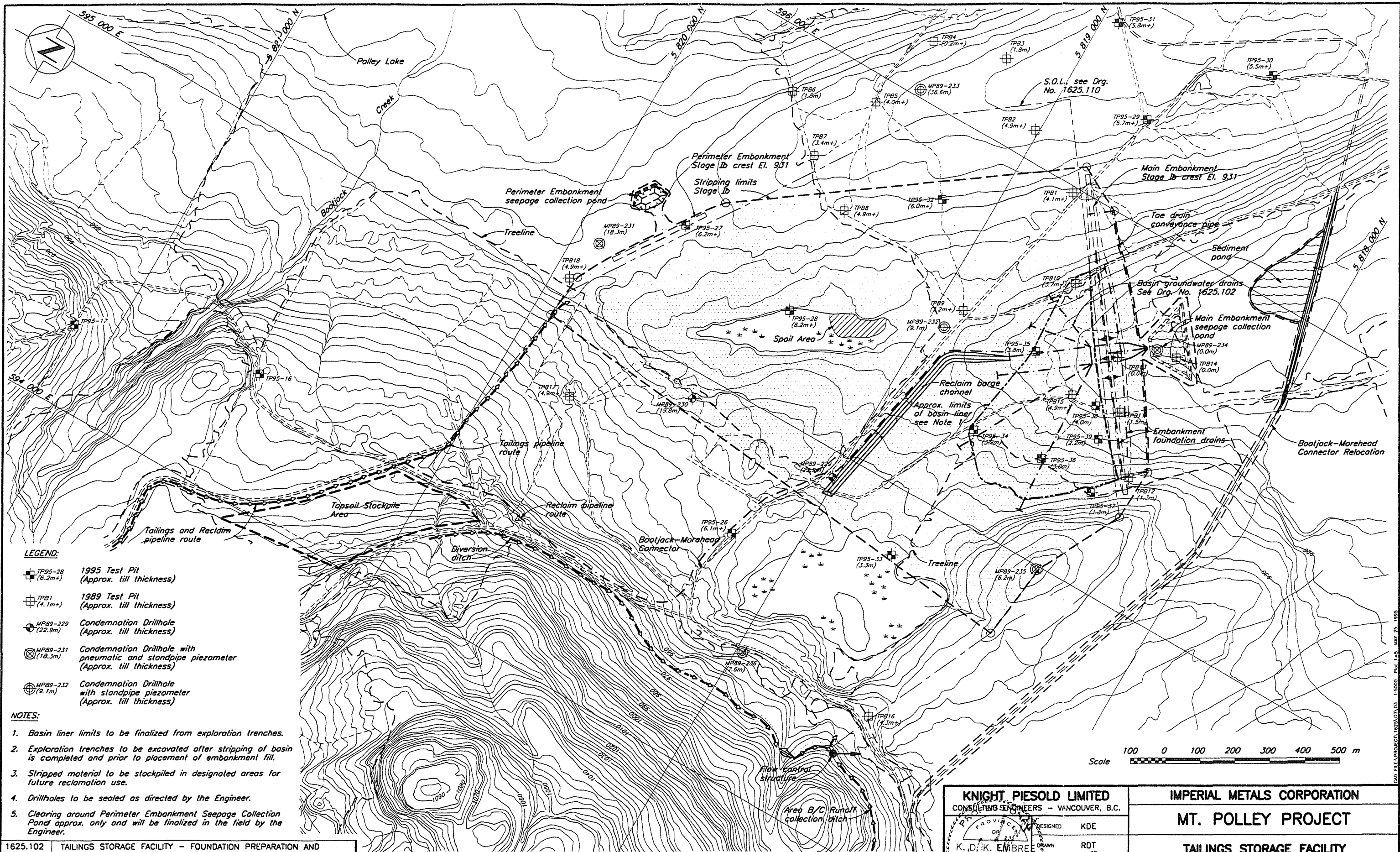

- LEGEND:**
- TP95-28 (6.2m+) 1995 Test Pit (Approx. till thickness)
 - TPB1 (4.1m+) 1989 Test Pit (Approx. till thickness)
 - MPB9-229 (22.9m) Condemnation Drillhole (Approx. till thickness)
 - MPB9-231 (18.3m) Condemnation Drillhole with pneumatic and standpipe piezometer (Approx. till thickness)
 - MPB9-232 (9.1m) Condemnation Drillhole with standpipe piezometer (Approx. till thickness)
- NOTES:**
1. Basin liner limits to be finalized from exploration trenches.
 2. Exploration trenches to be excavated after stripping of basin is completed and prior to placement of embankment fill.
 3. Stripped material to be stockpiled in designated areas for future reclamation use.
 4. Drillholes to be sealed as directed by the Engineer.
 5. Clearing around Perimeter Embankment Seepage Collection Pond approx. only and will be finalized in the field by the Engineer.

1625.102	TAILINGS STORAGE FACILITY - FOUNDATION PREPARATION AND BASIN LINER - SECTIONS AND DETAILS
1625.110	TAILINGS STORAGE FACILITY - STAGE Ib TAILINGS IMPOUNDMENT - GENERAL ARRANGEMENT
DRG. NO.	DESCRIPTION
REFERENCE DRAWINGS	

REV.	DATE	DESCRIPTION	APPROVED
REVISIONS			

REV.	DATE	DESCRIPTION	APPROVED
1	MAY 26/95	ISSUED FOR DESIGN REPORT	KJB
0	A.P.R. 5/95	ISSUED FOR REVIEW	
REVISIONS			

KNIGHT PIESOLD LIMITED
CONSULTING ENGINEERS - VANCOUVER, B.C.

DESIGNED: KDE
DRAWN: RDT
CHECKED: [Signature]
APPROVED: [Signature]

K. D. K. EMBRE
REGISTERED PROFESSIONAL ENGINEER

DATE: **APRIL 6, 1995**

IMPERIAL METALS CORPORATION

MT. POLLEY PROJECT

**TAILINGS STORAGE FACILITY
FOUNDATION PREPARATION
AND BASIN LINER**

SCALE AS SHOWN

DRG. NO. **1625.101**

REV. **1**

CAD FILE PROJECT 1625.101.DWG 1:5000 Plot 1 of 5 MAY 25, 1995

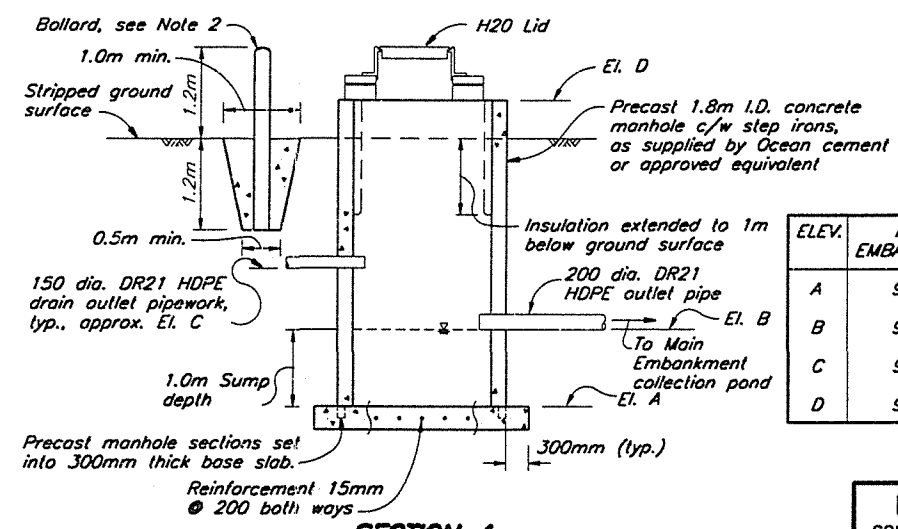
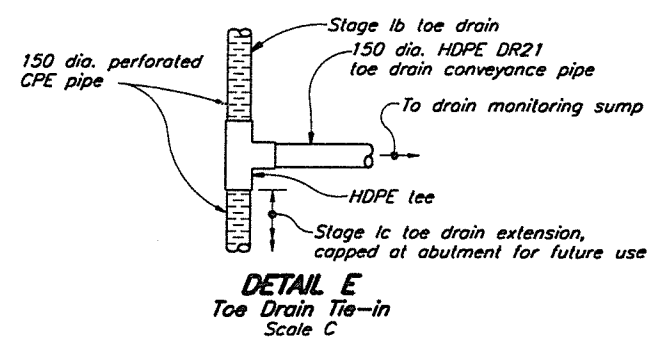
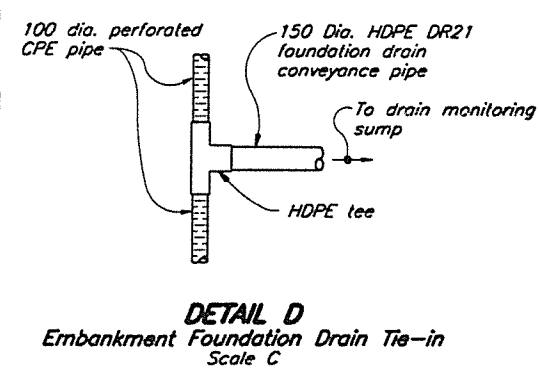
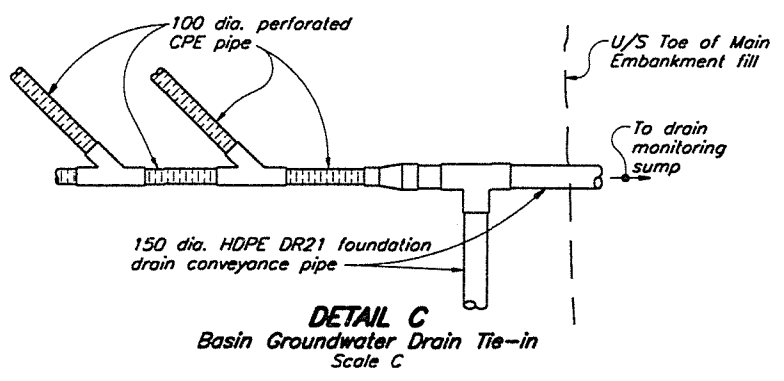
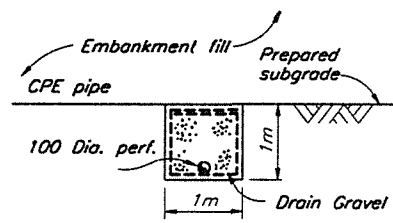
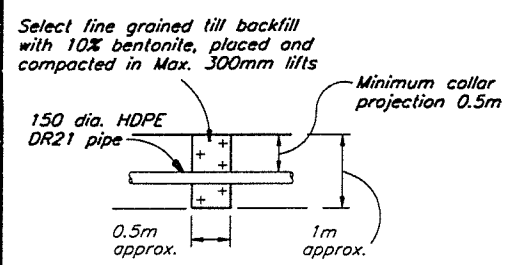
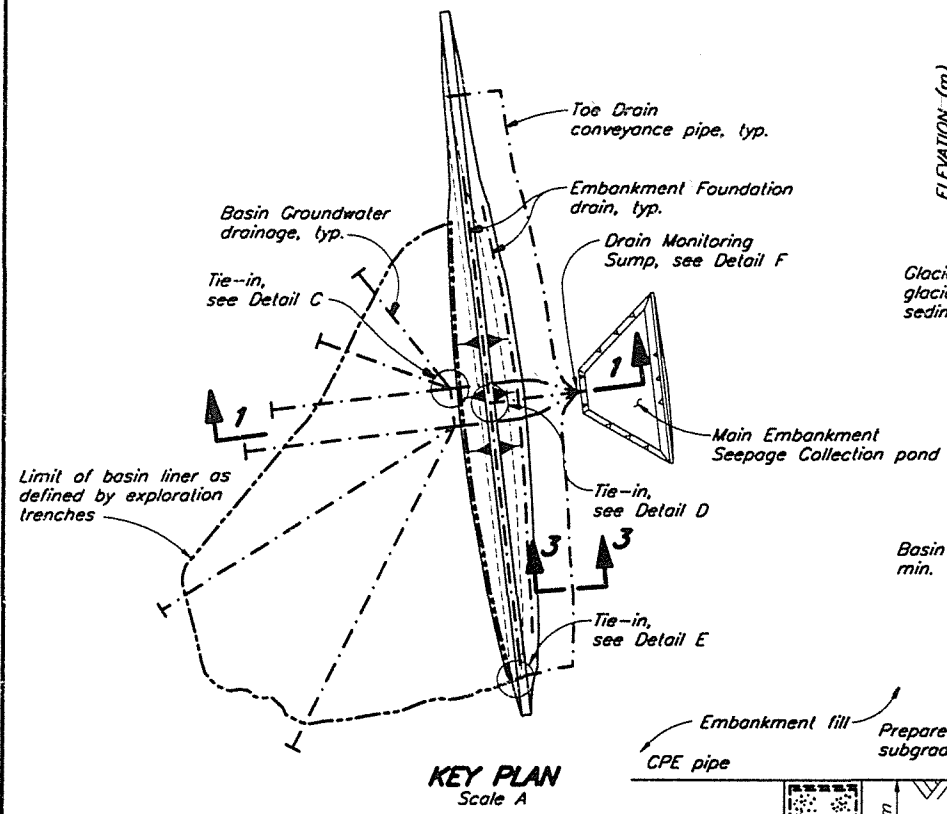
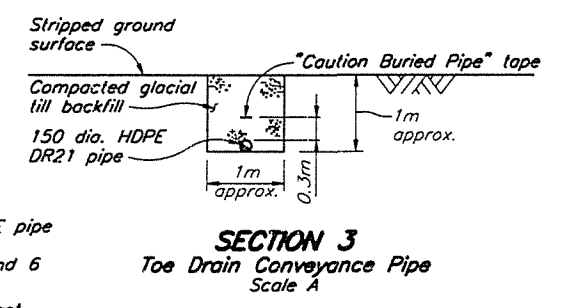
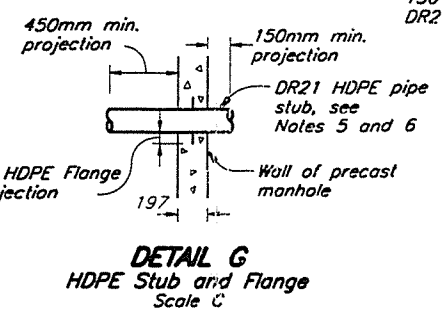
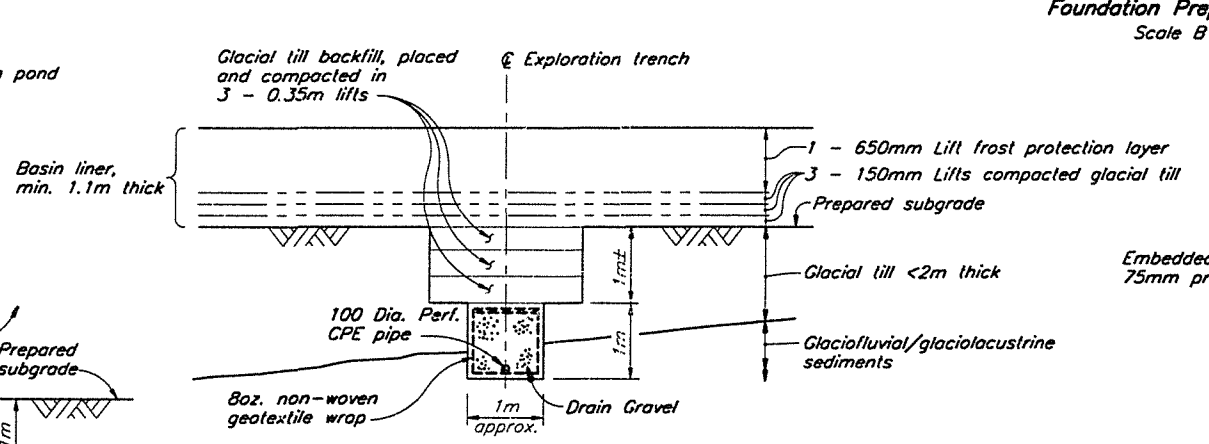
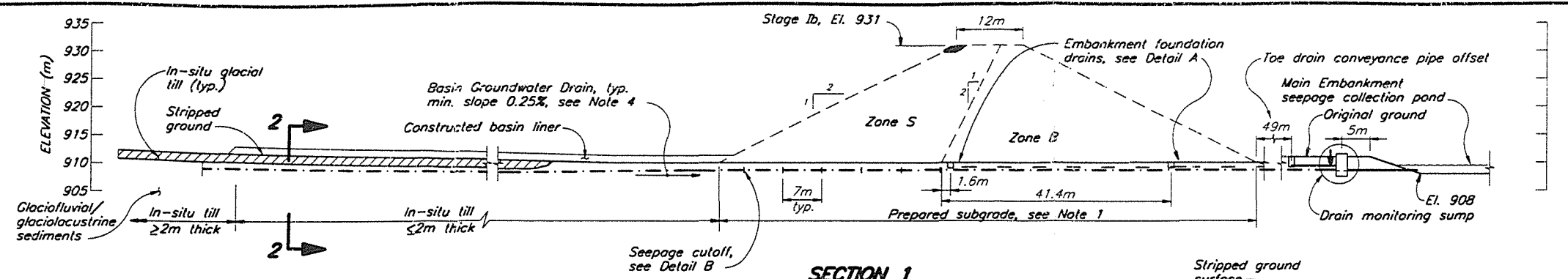

ELEV.	MAIN EMBANKMENT	PERIMETER EMBANKMENT
A	907.5	924.5
B	908.5	925.5
C	909.3	926.5
D	911.5	930.5

- NOTES**
- Subgrade preparation to comprise stripping of topsoil and organics and removing saturated materials to establish a competent, bearing surface for fill placement as directed by the Engineer.
 - Three ballards required at 120', 1.0m from sump. Ballards to be 200 dia. Std. Weight steel pipe filled with concrete.
 - Basin groundwater drains to be installed with a minimum continuous slope of 0.25% and without isolated low spots.
 - HDPE stubs and flanges to be cast into manhole.
 - For Main Embankment drain monitoring sump 150 dia. pipe stubs @ invert El. 909.3, 5 required. 200 dia. pipe stub @ invert El. 908.5, 1 required.
 - For Perimeter Embankment drain monitoring sump 150 dia. pipe stub, 1 required. 200 dia. pipe stub, 1 required.
 - Drain monitoring sump invert elevations may be adjusted in the field by the Engineer.
 - Buried pipework to be clearly marked by a line of stakes.

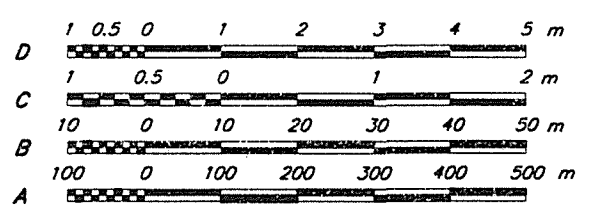

KNIGHT PIESOLD LIMITED
CONSULTING ENGINEERS - VANCOUVER, B.C.

DESIGNED: KDE
DRAWN: RDT/PAL/NSD
CHECKED: [Signature]
APPROVED: [Signature]

DATE: **APRIL 6, 1995**

IMPERIAL METALS CORPORATION

MT. POLLEY PROJECT

**TAILINGS STORAGE FACILITY
FOUNDATION PREPARATION AND
BASIN LINER
SECTION AND DETAILS**

SCALE AS SHOWN

DRG. NO. **1625.102**

REV. **1**

DRG. NO.	DESCRIPTION	REV.	DATE	DESCRIPTION	APPROVED
		1	MAY 26/95	ISSUED FOR DESIGN REPORT	[Signature]
		0	APR. 6/95	ISSUED FOR REVIEW	[Signature]



SETTING OUT POINTS			
Description	Point	Northing	Easting
Setting Out Line (S.O.L.)	S1	5 818 622.590	594 258.688
	S2	5 818 392.402	594 765.778
	S3	5 818 365.375	594 995.246
	S4	5 818 238.539	595 240.350
	S5	5 818 968.983	596 208.866
	S6	5 819 304.035	595 955.881
	S7	5 819 932.340	595 066.670
	S8	5 820 025.632	594 375.061
Stage Ib Main Embankment E	S9	5 818 891.014	596 150.000
	S10	5 818 199.059	595 230.000
Perimeter Embankment E	S11	5 819 705.338	595 404.339
	S12	5 819 869.082	595 160.766
Stripping Limits	S13	5 818 233.372	595 392.851
	S14	5 818 696.416	595 997.943
	S15	5 818 828.350	596 066.684
	S16	5 819 673.609	595 461.562
	S17	5 819 945.201	594 934.351
	Main Embankmt. Seepage Collection Pond	S19	5 818 417.116
S20		5 818 388.167	595 693.183
S21		5 818 279.658	595 693.183
S22		5 818 392.214	595 842.835
Reclaim Barge Channel	S23	5 818 743.870	595 479.103
	C6	5 818 856.841	595 365.834
	BC	5 818 879.675	595 408.055
	EC	5 818 903.862	595 375.481
	PI6	5 818 899.065	595 397.857
	S24	5 818 998.167	594 887.106
Bootjack - Moarehead Connector Relocation	C1	5 818 877.558	596 597.793
	BC	5 818 978.593	596 508.255
	EC	5 818 806.921	596 482.748
	PI1	5 818 900.547	596 424.933
	C2	5 818 344.391	596 662.738
	BC	5 818 387.543	596 741.718
	EC	5 818 259.115	596 691.513
	PI2	5 818 289.864	596 802.222
	C3	5 818 118.053	595 742.875
	BC	5 818 002.511	595 775.280
EC	5 817 998.051	595 742.013	
PI3	5 817 998.083	595 756.552	
C4	5 818 097.000	596 273.950	
BC	5 817 997.000	595 273.950	
EC	5 818 002.473	595 241.322	
PI4	5 817 997.000	595 257.177	
C5	5 818 228.844	594 248.367	
BC	5 818 333.078	594 283.514	
EC	5 818 307.478	594 171.448	
PI5	5 818 354.995	594 220.025	

LEGEND:

- ⊕ GW95-1 - Groundwater monitoring well
- C1 - Curve No. 1 (typ.)
- BC - Begin Curve
- EC - End Curve
- PI5 - Point of Intersection for Curve No. 5

NOTES

1. Setting Out Line (SOL) is the upstream shoulder of the Stage VII embankment.
2. Stripping and clearing required 5m beyond seepage collection ponds and pipeworks.
3. Perimeter Embankment Seepage Collection Pond to be located in the field by the Engineer.
4. Number and location of cross-drain culverts to be determined in the field by the Engineer.

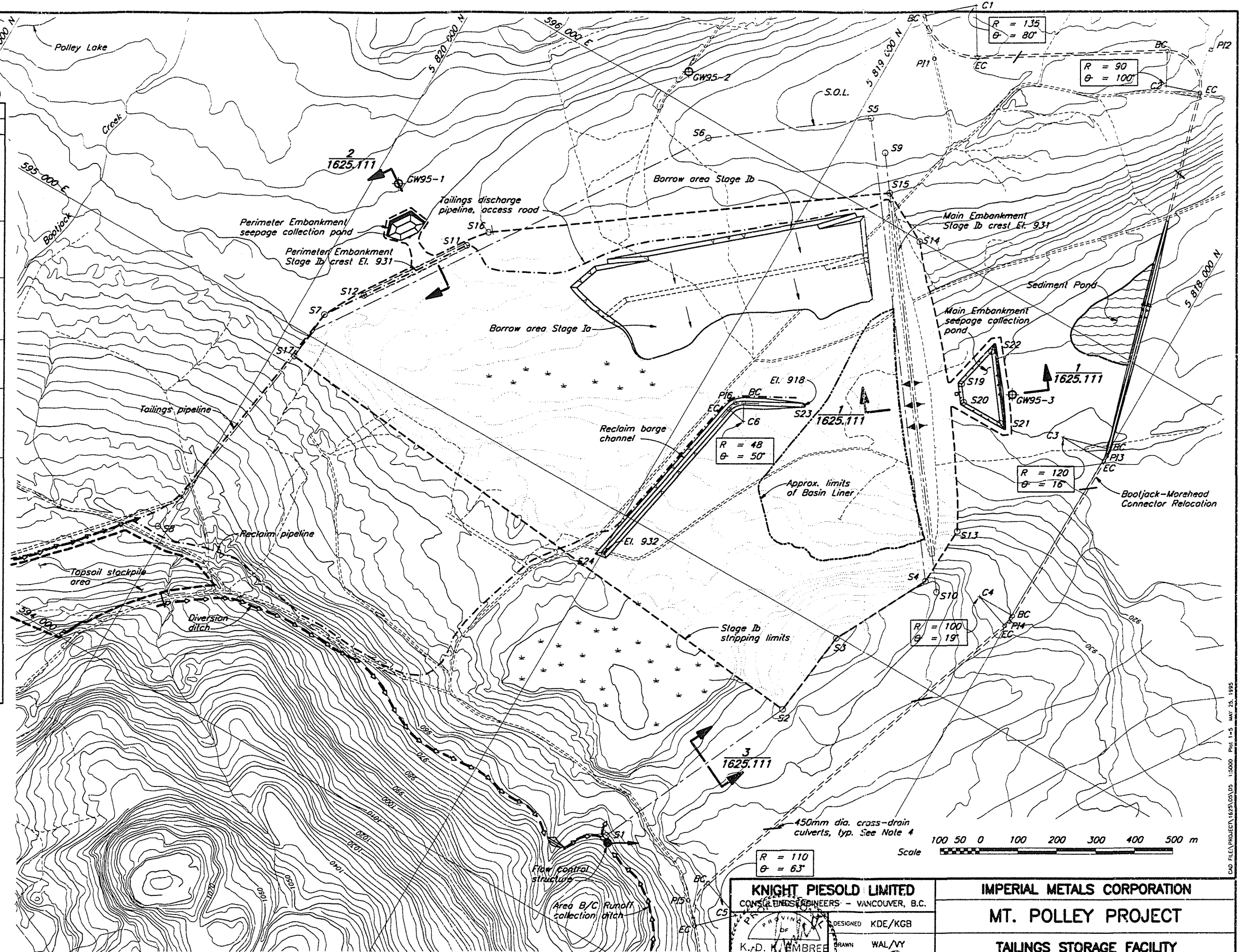

1625.111	TAILINGS STORAGE FACILITY - TAILINGS EMBANKMENT - SECTIONS AND DETAILS
DRG. NO.	DESCRIPTION
	REFERENCE DRAWINGS

REV.	DATE	DESCRIPTION	APPROVED

REV.	DATE	DESCRIPTION	APPROVED
1	MAY 26/95	ISSUED FOR DESIGN REPORT	KJB
0	APR. 6/95	ISSUED FOR REVIEW	

KNIGHT PIESOLD LIMITED
CONSULTING ENGINEERS - VANCOUVER, B.C.

DESIGNED KDE/KGB
DRAWN WAL/VY
CHECKED MRS
APPROVED KJB

K.D. HAMBRE
ENGINEER

DATE **APRIL 6, 1995**

IMPERIAL METALS CORPORATION

MT. POLLEY PROJECT

**TAILINGS STORAGE FACILITY
STAGE Ib TAILINGS IMPOUNDMENT
GENERAL ARRANGEMENT**

SCALE AS SHOWN

DRG. NO. **1625.110**

REV. **1**

CAD FILE PROJECT: 1625.DWG.DS 1:5000 Pkg. 1-5 MAY 25, 1995

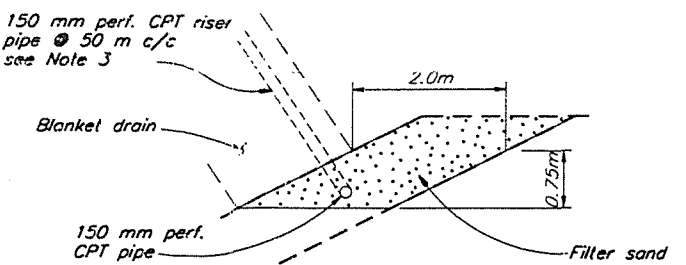
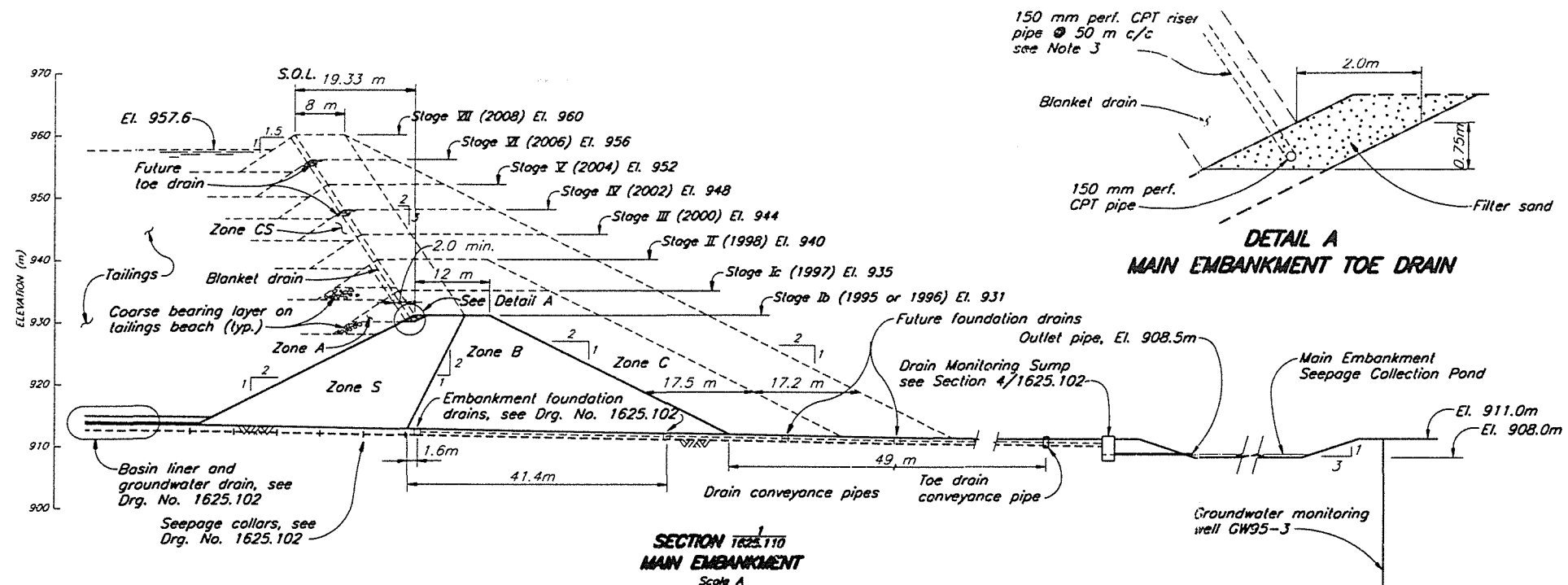

ZONE	MATERIAL TYPE	PLACEMENT AND COMPACTION REQUIREMENTS
Coarse Bearing Layer	Free draining durable waste rock fill or coarse sandy gravel	Placed and spread in maximum 1.0 m thick layers. Compaction as directed by the Engineer.
Chimney/Toe Drain	Filter sand	Placed and spread in maximum 1.0 m thick layers. Vibratory compaction as directed by the Engineer.
Drains	Drain Gravel	Placed and compacted as shown on the Drawings
S	Glacial till	Placed, moisture conditioned and spread in maximum 300 mm thick layers (after compaction). Vibratory compaction to 95% of modified proctor maximum dry density.
A	Glacial till	Placed, moisture conditioned and spread in maximum 600 mm thick layers (after compaction). Vibratory compaction to 90% of modified proctor maximum dry density.
B	Glacial till	Placed, moisture conditioned and spread in maximum 600 mm thick layers (after compaction). Vibratory compaction to 90% of modified proctor maximum dry density.
C	Random fill	Glacial till or other approved material placed in maximum 600 mm thick layers (after compaction). Vibratory compaction as required by the Engineer.
CS	Cycloned sand	Placed and spread in maximum 1.0 m thick layers. Vibratory compaction as directed by the Engineer.

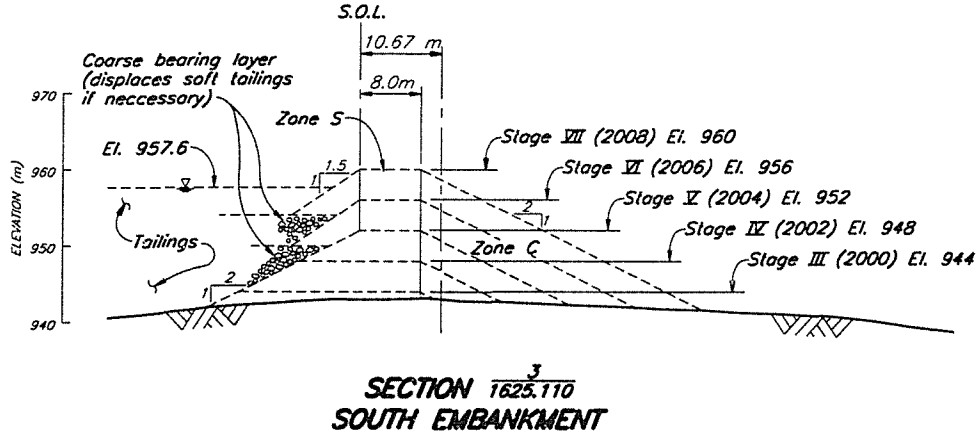
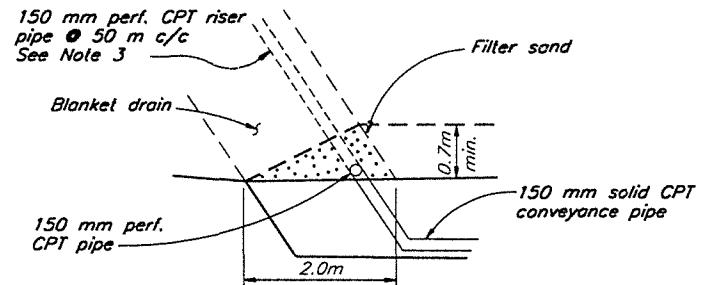
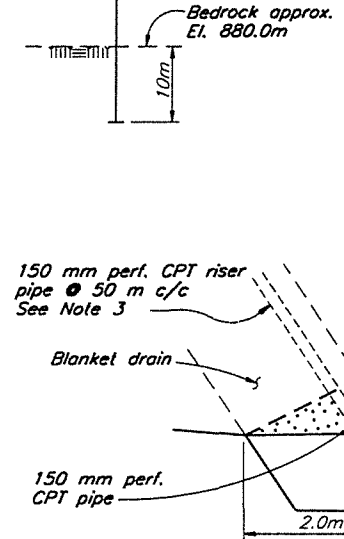
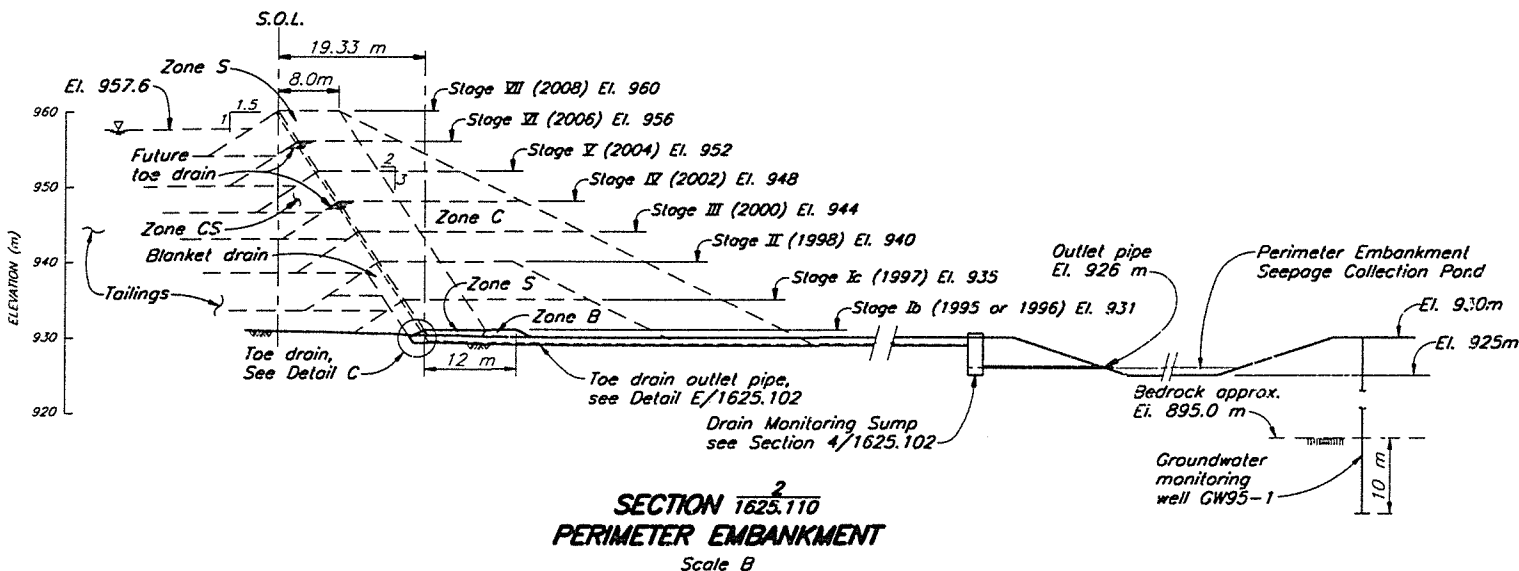

- NOTES**
- Groundwater monitoring wells to be installed by Others.
 - Perimeter Embankment slopes 2H:1V as per Main Embankment.
 - Perimeter Embankment seepage collection pond to be located in the field by the Engineer. Pipework invert elevations may be adjusted in the field by the Engineer.
 - CPT Riser pipes to be installed for extensions during future embankment raises. Stages IV and VI will include a toe drain that is connected to existing outlet pipework. Additional outlet pipework to seepage ponds will be included if required.

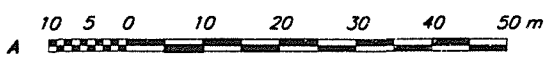

DRG. NO.	DESCRIPTION	REV.	DATE	DESCRIPTION	APPROVED
1625.102	TAILINGS STORAGE FACILITY - FOUNDATION PREPARATION AND BASIN LINER - SECTIONS AND DETAILS				
1625.110	TAILINGS STORAGE FACILITY - STAGE Ia/Ib TAILINGS IMPOUNDMENT - GENERAL ARRANGEMENT				

REV.	DATE	DESCRIPTION	APPROVED
1	MAY 25/95	ISSUED FOR DESIGN REPORT	KJB
0	APR. 6/95	ISSUED FOR REVIEW	

REV.	DATE	DESCRIPTION	APPROVED
1	MAY 25/95	ISSUED FOR DESIGN REPORT	KJB
0	APR. 6/95	ISSUED FOR REVIEW	

KNIGHT PIESOLD LIMITED
CONSULTING ENGINEERS - VANCOUVER, B.C.

DESIGNED: KDE
DRAWN: WAL/VY
CHECKED: MS
APPROVED: KJB

DATE: **APRIL 6, 1995**

IMPERIAL METALS CORPORATION

MT. POLLEY PROJECT

TAILINGS STORAGE FACILITY
TAILINGS EMBANKMENT
SECTIONS AND DETAILS

DRG. NO. **1625.111** REV. **1**

CAD FILE PROJECT 1625.01.D1 1:500 Pkg. 1-03 MAY 25, 1995

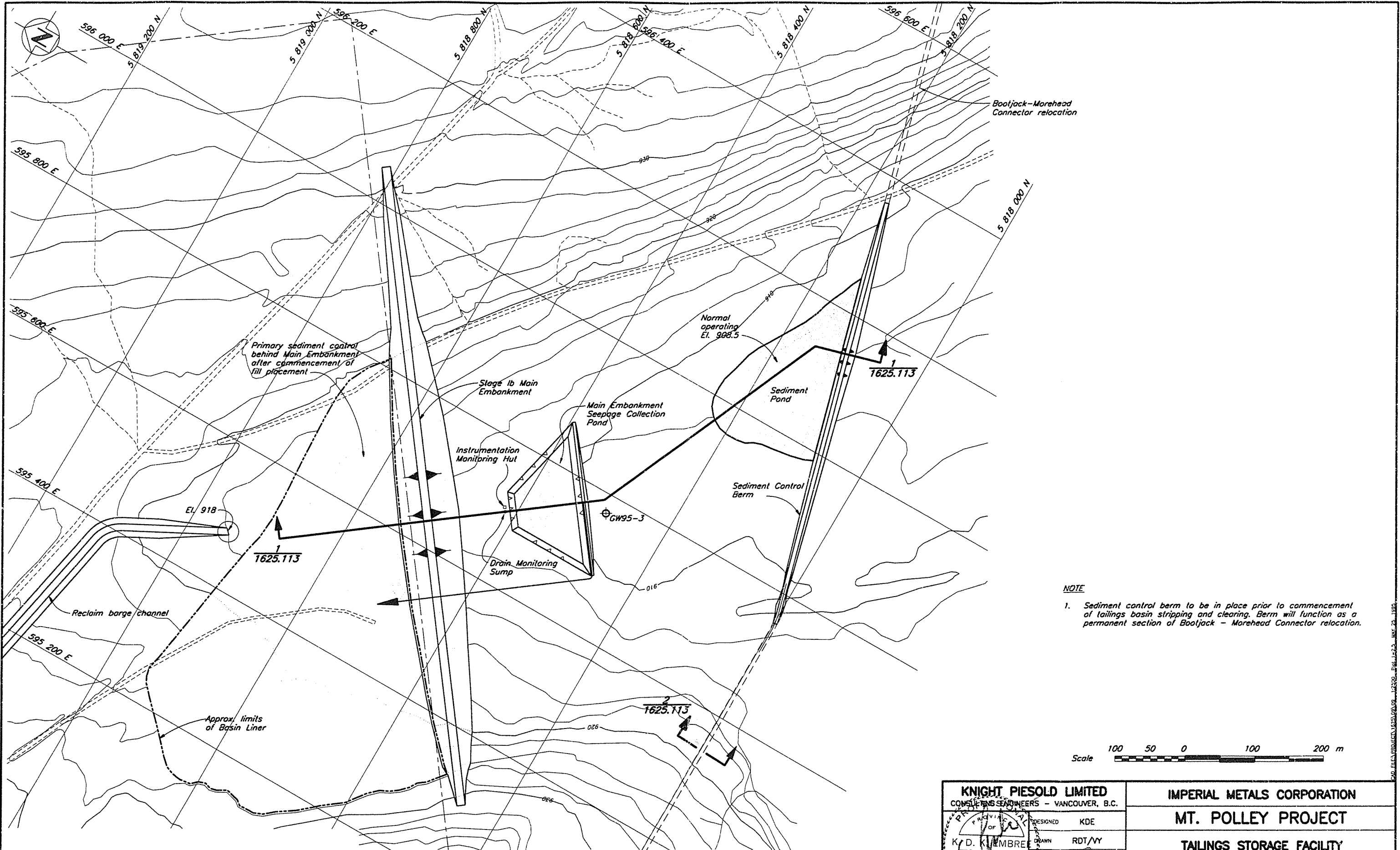

NOTE
 1. Sediment control berm to be in place prior to commencement of tailings basin stripping and clearing. Berm will function as a permanent section of Bootjack - Morehead Connector relocation.



1625.113	SEDIMENT CONTROL AND SEEPAGE COLLECTION - SECTIONS AND DETAILS
DRG. NO.	DESCRIPTION
REFERENCE DRAWINGS	

REV.	DATE	DESCRIPTION	APPROVED

REV.	DATE	DESCRIPTION	APPROVED
1	MAY 26/95	ISSUED FOR DESIGN REPORT	KJB
0	APR. 6/95	ISSUED FOR REVIEW	

KNIGHT PIESOLD LIMITED
 CONSULTING ENGINEERS - VANCOUVER, B.C.

DESIGNED: KDE
 DRAWN: RDT/vy
 CHECKED: MBS
 APPROVED: KJB

DATE: **APRIL 6, 1995**

IMPERIAL METALS CORPORATION

MT. POLLEY PROJECT

**TAILINGS STORAGE FACILITY
 SEDIMENT CONTROL AND
 SEEPAGE COLLECTION**

SCALE AS SHOWN

DRG. NO. **1625.112**

REV. **1**

500 - FIELD CONSULTING ENGINEERS - VANCOUVER, B.C. - 1995 - 1011-1-25 - MAY 26 - 1995

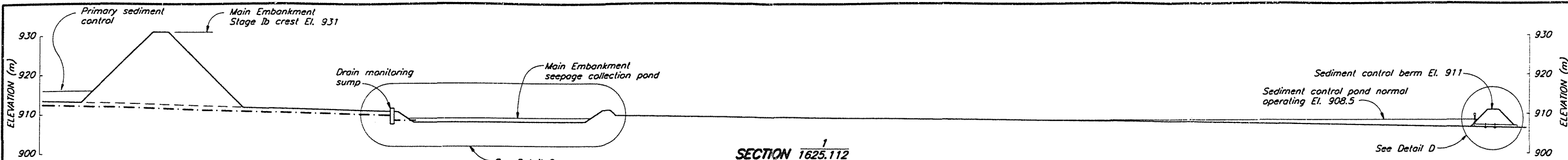

SECTION 1
SEDIMENT CONTROL AND SEEPAGE PROFILE
 Horiz. Scale A, Vert. Scale D

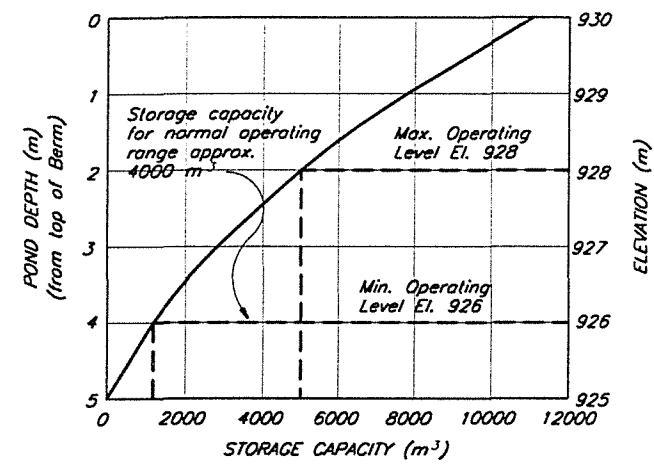

PERIMETER EMBANKMENT SEEPAGE COLLECTION POND DEPTH/CAPACITY RELATIONSHIP

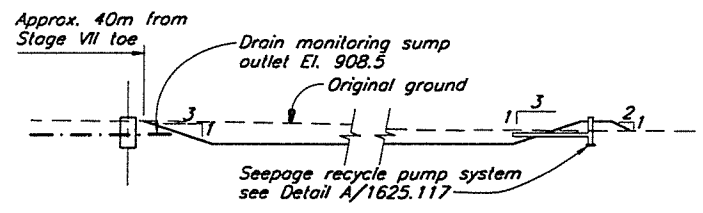

DETAIL C
MAIN EMBANKMENT SEEPAGE COLLECTION POND
 Scale A

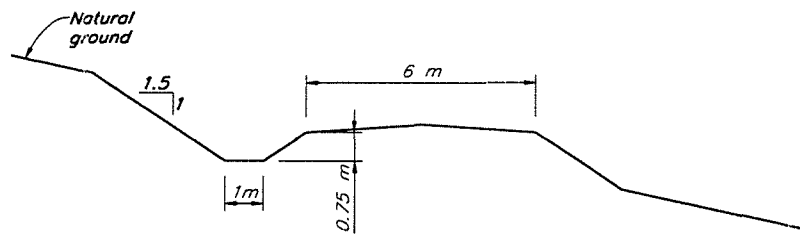

SECTION 2
TYPICAL SECTION FOR BOOTJACK-MOREHEAD CONNECTOR RELOCATION
 Scale C

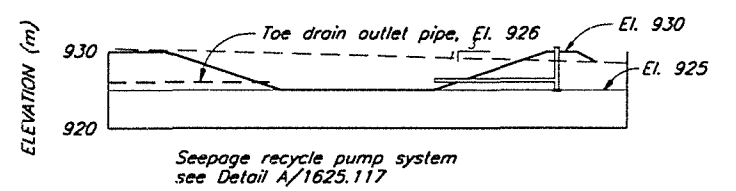

PERIMETER EMBANKMENT SEEPAGE COLLECTION POND
 Scale A

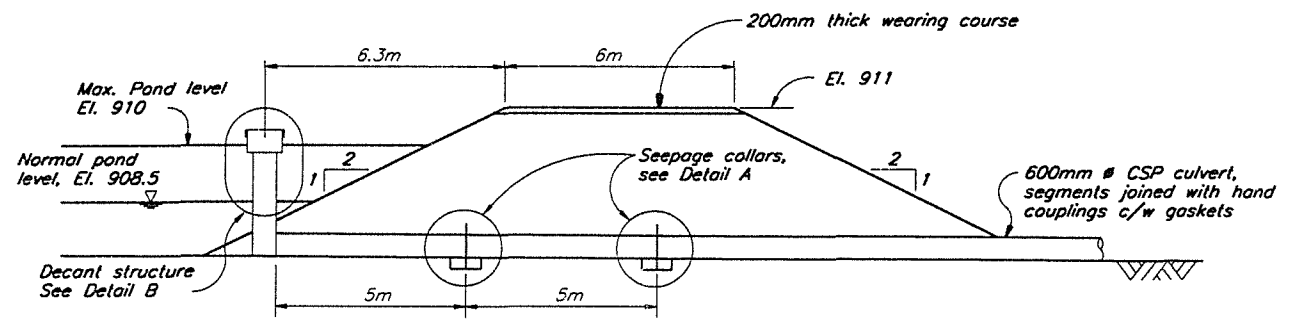

DETAIL D
SEDIMENT CONTROL BERM
 Scale C

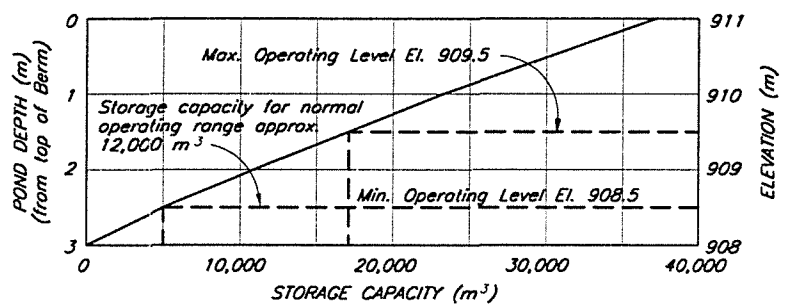

MAIN EMBANKMENT SEEPAGE COLLECTION POND DEPTH/CAPACITY RELATIONSHIP

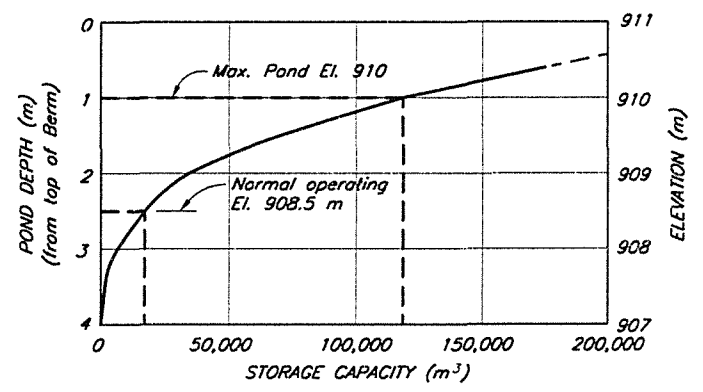

SEDIMENT POND DEPTH/CAPACITY RELATIONSHIP

NOTES

1. Glacial till for sediment control berm placed and compacted in maximum 500mm lifts to 90% of Modified Proctor Maximum Density.
2. Perimeter embankment seepage collection pond will be sized to have a min. live storage capacity of approx. 4000 m³.

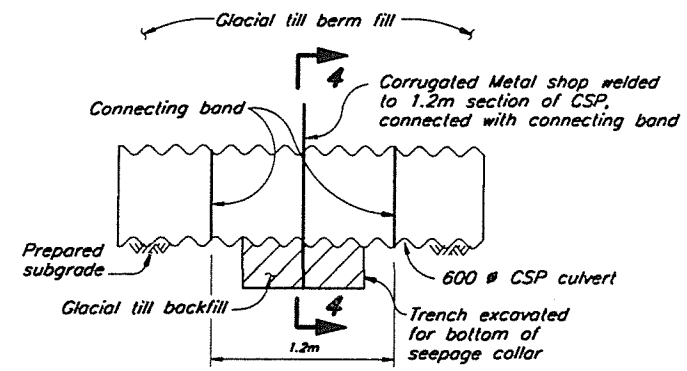

DETAIL A
SEEPAGE COLLAR
 Scale B

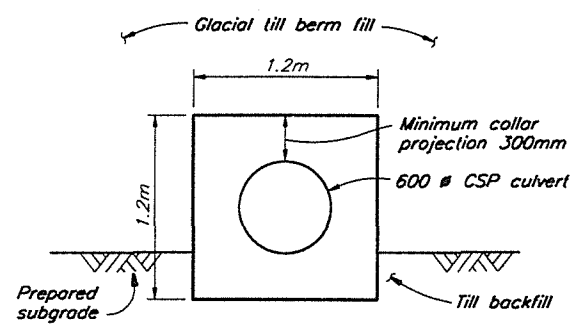

SECTION 4
 Scale B

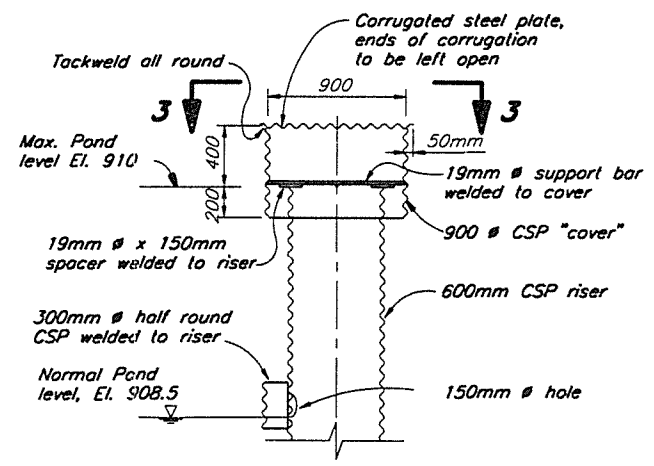

DETAIL B
DECANT STRUCTURE
 Scale B

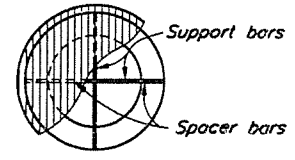

SECTION 3
 Scale B

D	20	10	0	20	40	60	80	100	m
C	2	1	0	2	4	6	8	10	m
B	1000	500	0	1000	2000	mm			
A	10	5	0	10	20	30	40	50	m

1625.112	TAILINGS STORAGE FACILITY - SEDIMENT CONTROL AND SEEPAGE COLLECTION
1625.117	TAILINGS STORAGE FACILITY - TAILINGS DISTRIBUTION AND RECLAIM SYSTEM - SECTIONS AND DETAILS
DRG. NO.	DESCRIPTION
REFERENCE DRAWINGS	

REV.	DATE	DESCRIPTION	APPROVED
REVISIONS			

1	MAY 26/95	ISSUED FOR DESIGN REPORT	KJB
0	APR. 6/95	ISSUED FOR REVIEW	
REV.	DATE	DESCRIPTION	APPROVED
REVISIONS			

KNIGHT PIESOLD LIMITED
 CONSULTING ENGINEERS - VANCOUVER, B.C.

DESIGNED: KDE
 DRAWN: VY
 CHECKED: [Signature]
 APPROVED: [Signature]

DATE: **APRIL 6, 1995**

IMPERIAL METALS CORPORATION

MT. POLLEY PROJECT

TAILINGS STORAGE FACILITY
SEDIMENT CONTROL AND SEEPAGE COLLECTION - SECTIONS AND DETAILS

SCALE AS SHOWN
 DRG. NO. **1625.113**
 REV. **1**

CAD FILE: \PROJECT\1625\010.DWG 1:500 Pkg. 1-6-95 MAY 19, 1995

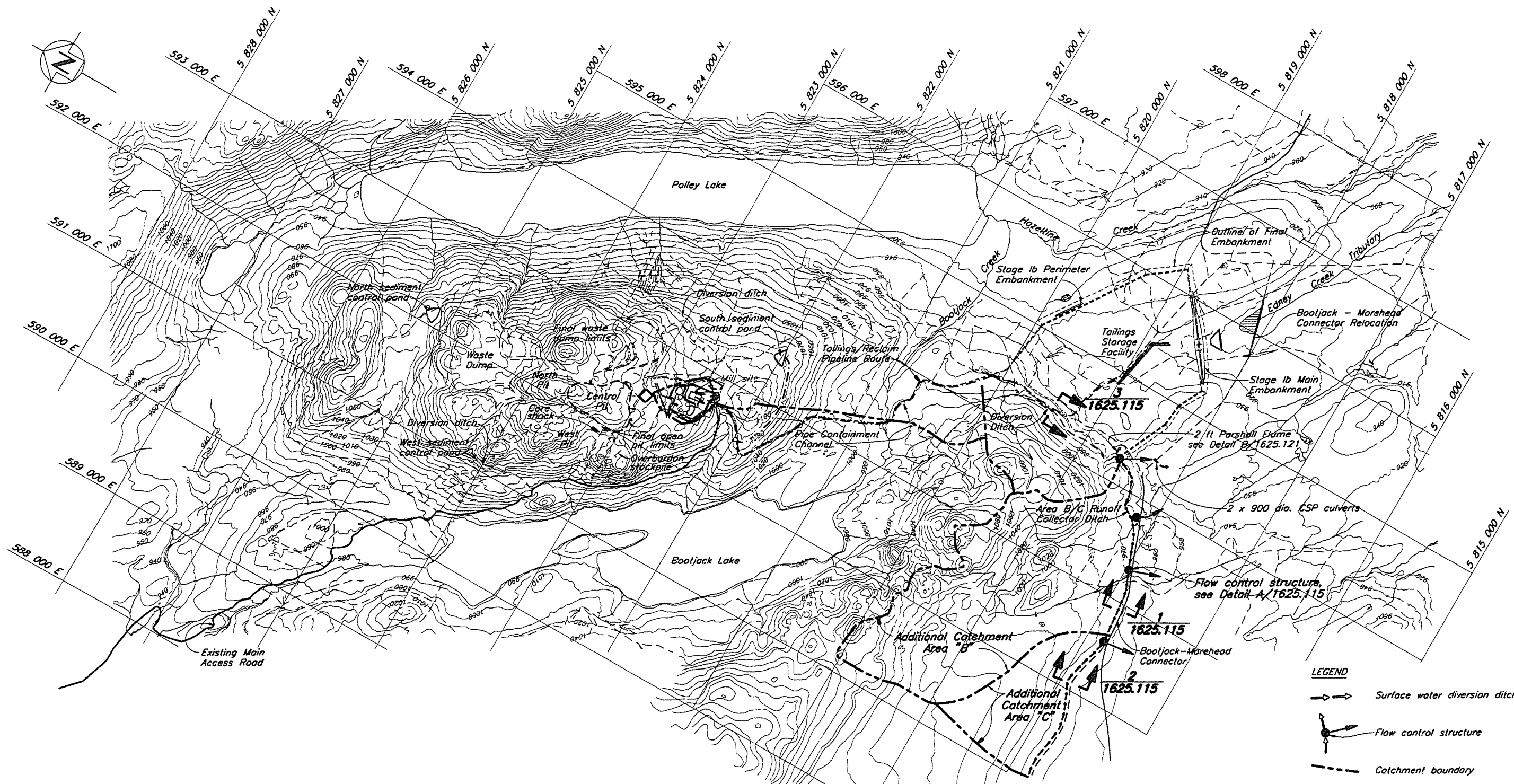

LEGEND

- Surface water diversion ditch
- Flow control structure
- Catchment boundary

NOTE
1. Mill site layout to be finalized by C.S.F.M.

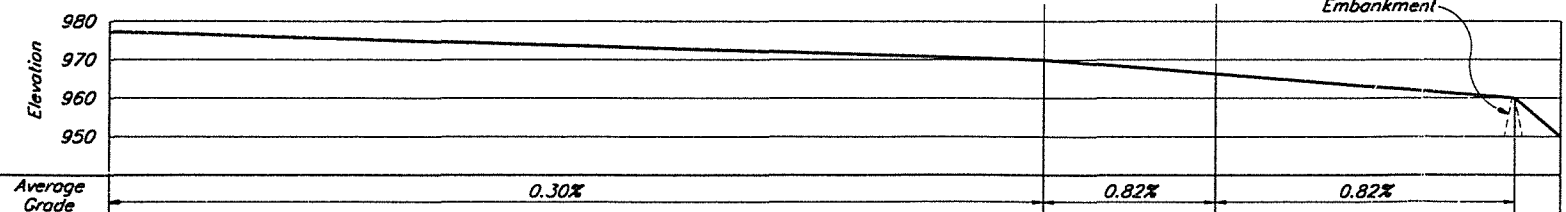

AREA B/C RUNOFF COLLECTION DITCH PROFILE

1625.115 TAILINGS STORAGE FACILITY - SURFACE WATER CONTROL - SECTIONS AND DETAILS		REV.	DATE	DESCRIPTION	APPROVED
DRG. NO.	DESCRIPTION	REV.	DATE	DESCRIPTION	APPROVED
REFERENCE DRAWINGS		REVISIONS		REVISIONS	

1	MAY 26/95	ISSUED FOR DESIGN REPORT	KJB
0	APR. 6/95	ISSUED FOR REVIEW	

KNIGHT PIESOLD LIMITED
CONSULTING ENGINEERS - VANCOUVER, B.C.

DESIGNED: MBS
DRAWN: N.A. Laroda
CHECKED: [Signature]
APPROVED: KJB

DATE: **APRIL 6, 1995**

IMPERIAL METALS CORPORATION

MT. POLLEY PROJECT

TAILINGS STORAGE FACILITY SURFACE WATER CONTROL PLAN AND PROFILE

SCALE AS SHOWN

DRG. NO. **1625.114**

REV. **1**

CAD FILE PROJECT: 1625.013.D15 1-20000 PLOT: 1-20 MAY 25, 1995

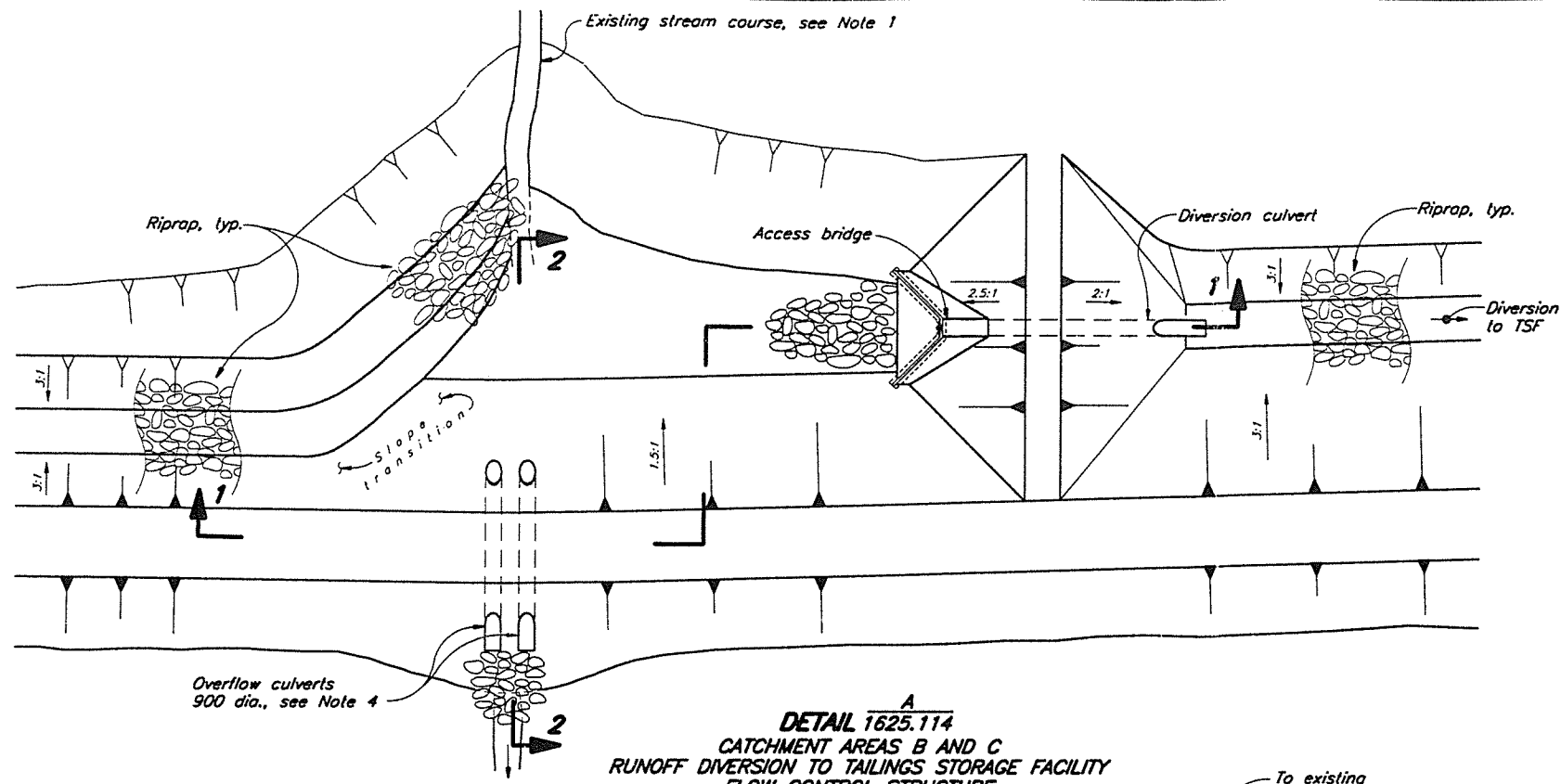

DETAIL A
1625.114
 CATCHMENT AREAS B AND C
 RUNOFF DIVERSION TO TAILINGS STORAGE FACILITY
 FLOW CONTROL STRUCTURE
 Scale A

- NOTES**
- Detailed setting out of Area B and C runoff collection ditch and flow control structures may be adjusted by the Engineer to suit detailed topography of existing stream courses.
 - Area B and C runoff collection ditches designed for 50 yr. precipitation event peak flows.
 - Riprap shall be placed as directed by the Engineer based on ground conditions and local profile of ditches.
 - Flow control structures No. 1, 2 and 3 have 1 overflow culvert, No. 4 has 2 overflow culverts.

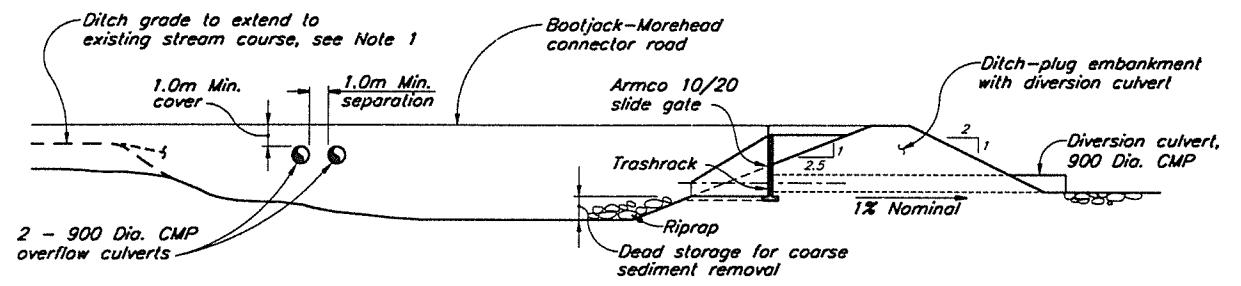
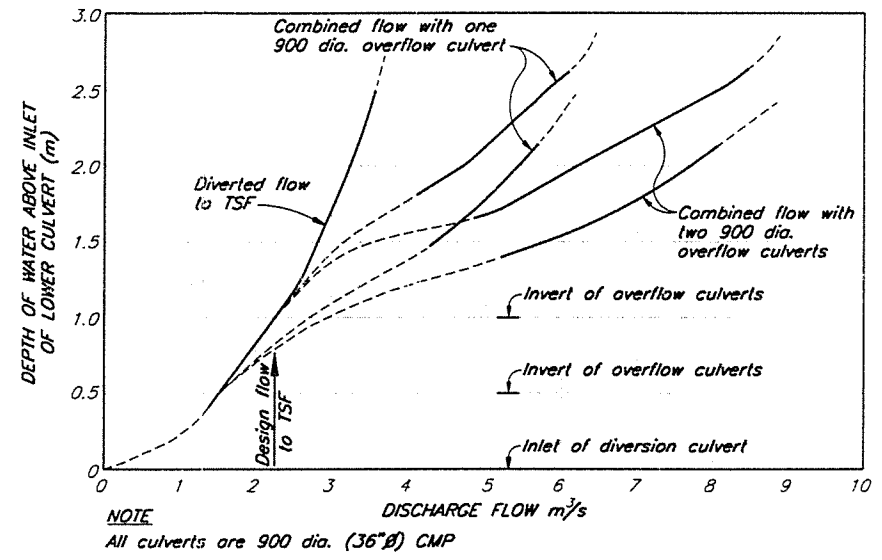

SECTION 1
 Scale A

NOTE
 Elevation difference affects quantity of diverted flow as shown on depth-discharge curves on this Drawing.

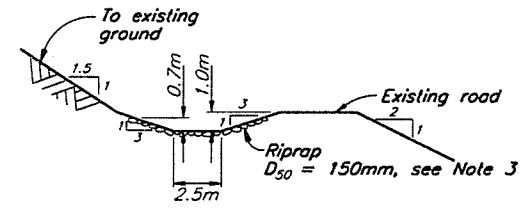

SECTION 1
 1625.114
 Scale A

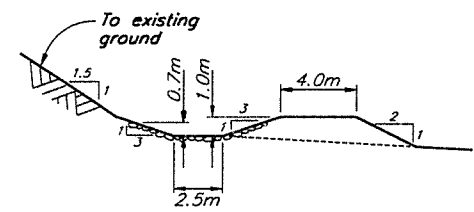

SECTION 2
 1625.114
 Scale A

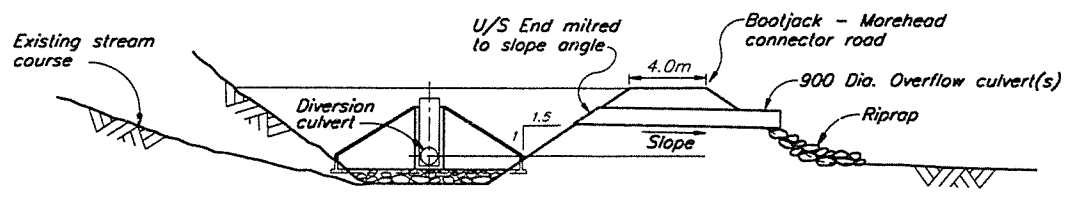

SECTION 2
 Scale A

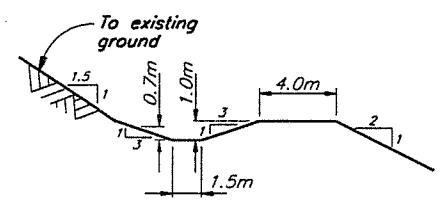

SECTION 3
 1625.114
 Scale A



1625.114	TAILINGS STORAGE FACILITY - SURFACE WATER CONTROL - RECLAIM SYSTEM - PLAN AND PROFILE
DRG. NO.	DESCRIPTION
REFERENCE DRAWINGS	

REV.	DATE	DESCRIPTION	APPROVED

REV.	DATE	DESCRIPTION	APPROVED
1	MAY 26/95	ISSUED FOR DESIGN REPORT	KJB
0	APR. 6/95	ISSUED FOR REVIEW	

KNIGHT PIESOLD LIMITED
 CONSULTING ENGINEERS - VANCOUVER, B.C.

DESIGNED: MBS
 DRAWN: W.A. Lahoda
 CHECKED: KJB
 APPROVED: KJB

PROVINCIAL REGISTERED ENGINEER

IMPERIAL METALS CORPORATION

MT. POLLEY PROJECT

TAILINGS STORAGE FACILITY SURFACE WATER CONTROL SECTIONS AND DETAILS

DATE: **APRIL 6, 1995** SCALE AS SHOWN
 DRG. NO. **1625.115** REV. **1**

C:\P\PROJECTS\1625\1625.DWG 1:100 Plot 1-01 MAY 25 1995

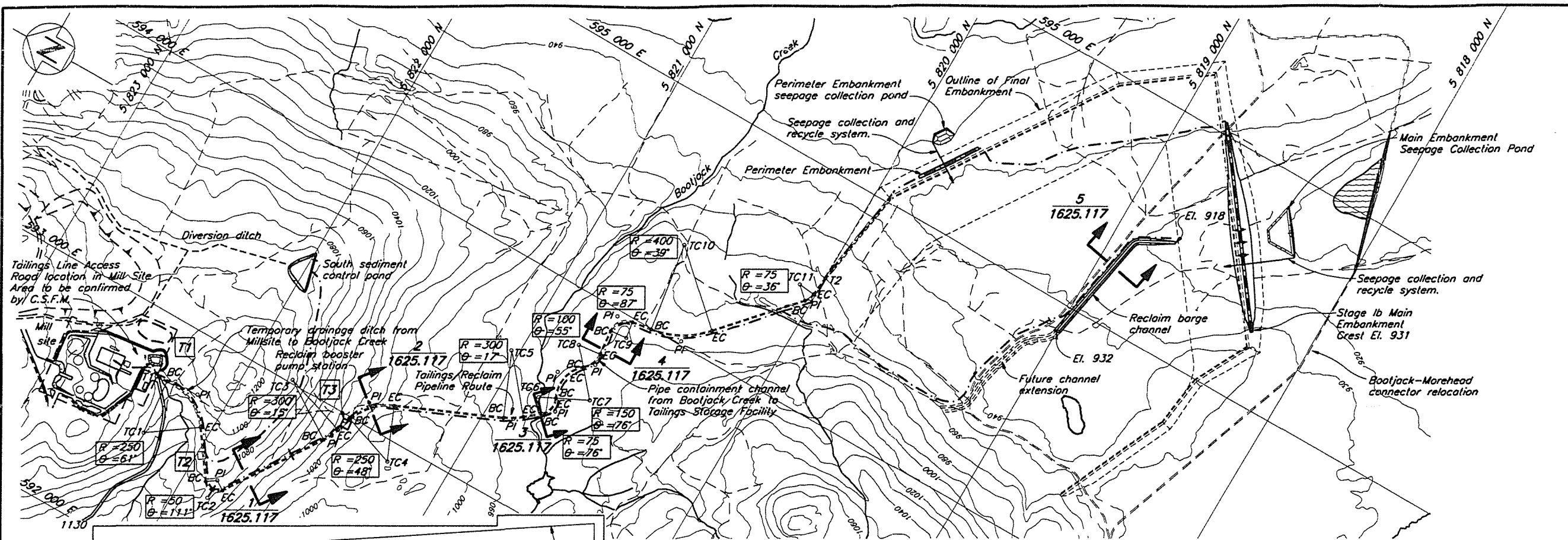

SETTING OUT POINTS		
Point	Northing	Easting
T1	5 822 326.825	592 728.418
TC1	5 822 249.362	592 485.485
BC	5 822 276.960	592 733.957
EC	5 822 046.266	592 631.266
PI	5 822 131.569	592 750.106
TC2	5 821 864.147	592 463.292
BC	5 821 904.766	592 434.135
EC	5 821 822.231	592 436.033
PI	5 821 862.111	592 374.711
TC3	5 821 802.714	593 016.314
BC	5 821 551.219	592 852.758
EC	5 821 517.947	592 921.933
PI	5 821 530.122	592 885.200
TC4	5 821 258.152	592 911.135
BC	5 821 495.458	592 989.786
EC	5 821 357.902	593 140.373
PI	5 821 460.320	593 095.808
TC5	5 821 034.980	593 608.059
BC	5 820 915.281	593 332.973
EC	5 820 841.176	593 379.061
PI	5 820 874.841	593 350.570
TC6	5 820 828.199	593 488.298
BC	5 820 779.748	593 431.048
EC	5 820 761.122	593 521.849
PI	5 820 734.752	593 469.130
TC7	5 820 626.968	593 588.951
BC	5 820 761.122	593 521.849
EC	5 820 724.705	593 702.739
PI	5 820 813.467	593 626.498
TC8	5 820 789.863	593 778.597
BC	5 820 724.705	593 702.739
EC	5 820 690.352	593 788.480
PI	5 820 685.206	593 736.666
TC9	5 820 626.991	593 909.389
BC	5 820 701.624	593 901.976
EC	5 820 638.300	593 983.531
PI	5 820 708.658	593 972.800
TC10	5 820 612.021	594 392.165
BC	5 820 551.708	593 996.739
EC	5 820 314.310	594 125.018
PI	5 820 410.028	594 018.349
TC11	5 820 083.239	594 494.822
BC	5 820 027.418	594 444.732
EC	5 820 008.600	594 487.469
PI	5 820 011.009	594 463.018
T2	5 820 000.045	594 574.311

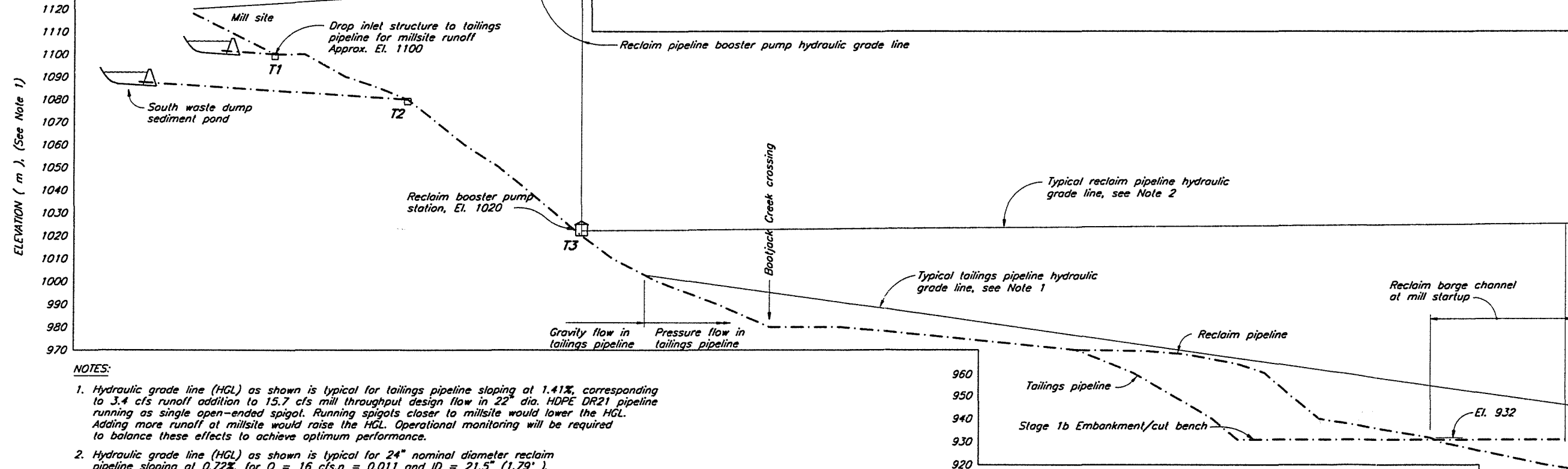

NOTES:

- Hydraulic grade line (HGL) as shown is typical for tailings pipeline sloping at 1.41%, corresponding to 3.4 cfs runoff addition to 15.7 cfs mill throughput design flow in 22" dia. HDPE DR21 pipeline running as single open-ended spigot. Running spigots closer to millsite would lower the HGL. Adding more runoff at millsite would raise the HGL. Operational monitoring will be required to balance these effects to achieve optimum performance.
- Hydraulic grade line (HGL) as shown is typical for 24" nominal diameter reclaim pipeline sloping at 0.72%, for $Q = 16 \text{ cfs}, n = 0.011$ and $ID = 21.5" (1.79')$. Raw water tank inlet assumed at El. 1120.
- Final location of cross drain culverts to be determined in the field by the Engineer.
- Final location of Bootjack Creek crossing to be determined in the field by the Engineer.
- Vertical exaggeration = 10 times.
- Mill site layout to be finalized by C.S.F.M.

1625.117	TAILINGS STORAGE FACILITY - TAILINGS DISTRIBUTION AND RECLAIM SYSTEM - SECTIONS AND DETAILS
DRG. NO.	DESCRIPTION
	REFERENCE DRAWINGS

REV.	DATE	DESCRIPTION	APPROVED
REVISIONS			

1	MAY 26/95	ISSUED FOR DESIGN REPORT	
0	APR. 6/95	ISSUED FOR REVIEW	
REV.	DATE	DESCRIPTION	APPROVED
REVISIONS			



KNIGHT PIESOLD LIMITED
CONSULTING ENGINEERS - VANCOUVER, B.C.

DESIGNED: MBS
DRAWN: VY
CHECKED: KJB
APPROVED: KJB

DATE: **APRIL 6, 1995**

IMPERIAL METALS CORPORATION

MT. POLLEY PROJECT

**TAILINGS STORAGE FACILITY
TAILINGS DISTRIBUTION AND
RECLAIM SYSTEM - PLAN AND PROFILE**

SCALE AS SHOWN
DRG. NO. **1625.116**
REV. **1**

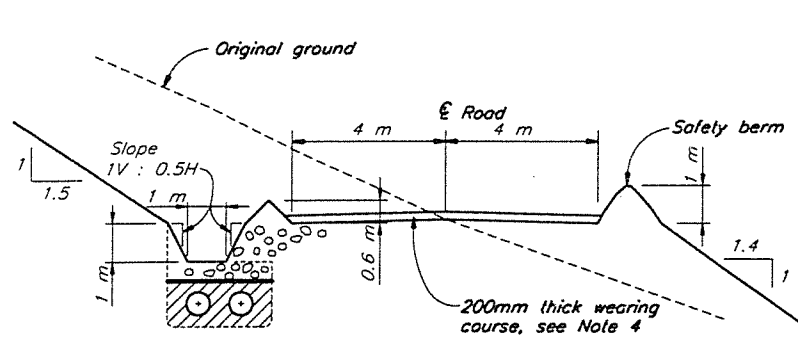

SECTION 1625.116
TAILINGS ACCESS ROAD,
MILLSITE TO BOOTJACK CREEK
Scale B

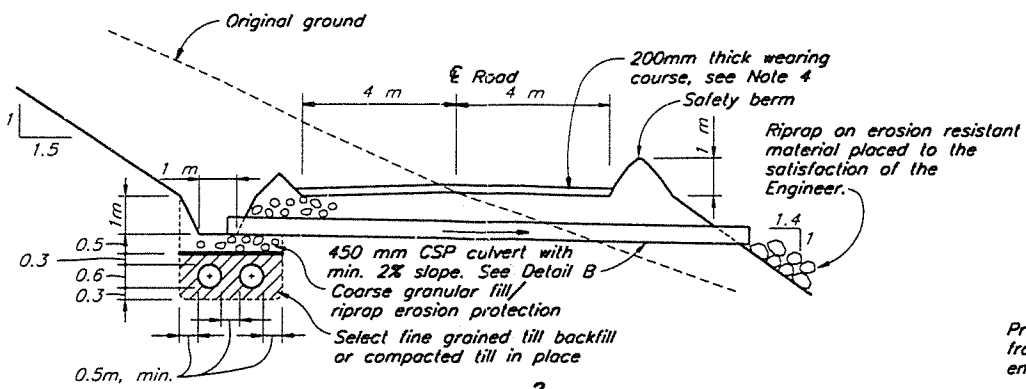

SECTION 1625.116
CROSS-DRAIN CULVERT FOR TAILINGS ACCESS ROAD,
MILLSITE TO BOOTJACK CREEK
Scale B

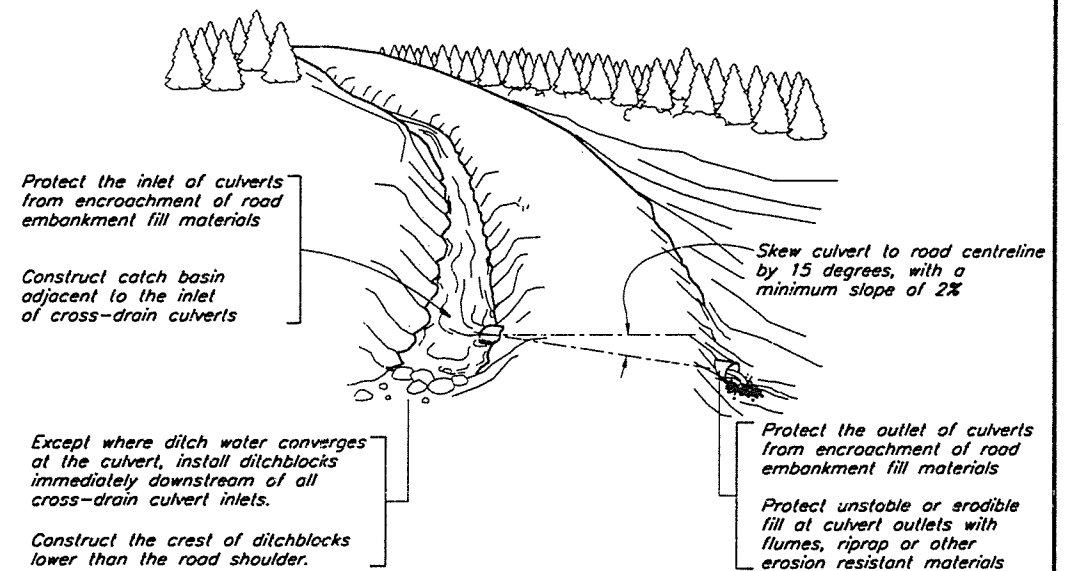

DETAIL B
TYPICAL CROSS-DRAIN CULVERT

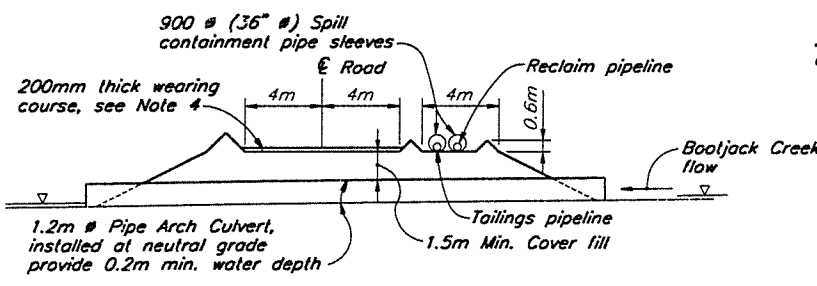

SECTION 1625.116
TAILINGS ACCESS ROAD
BOOTJACK CREEK CROSSING
Scale A

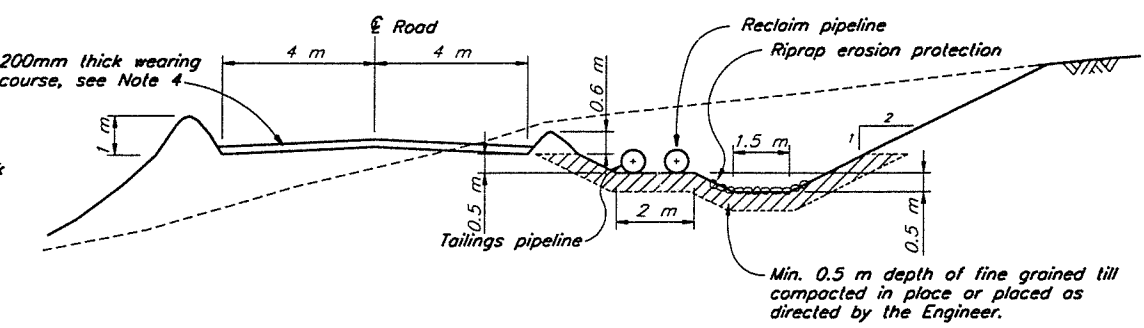

SECTION 1625.116
TAILINGS ACCESS ROAD AND PIPE CONTAINMENT CHANNEL,
BOOTJACK CREEK TO TAILINGS STORAGE FACILITY
Scale B

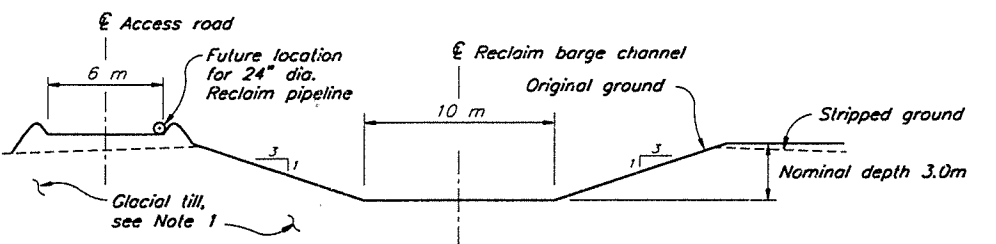

SECTION 1625.116
RECLAIM BARGE CHANNEL
Scale A

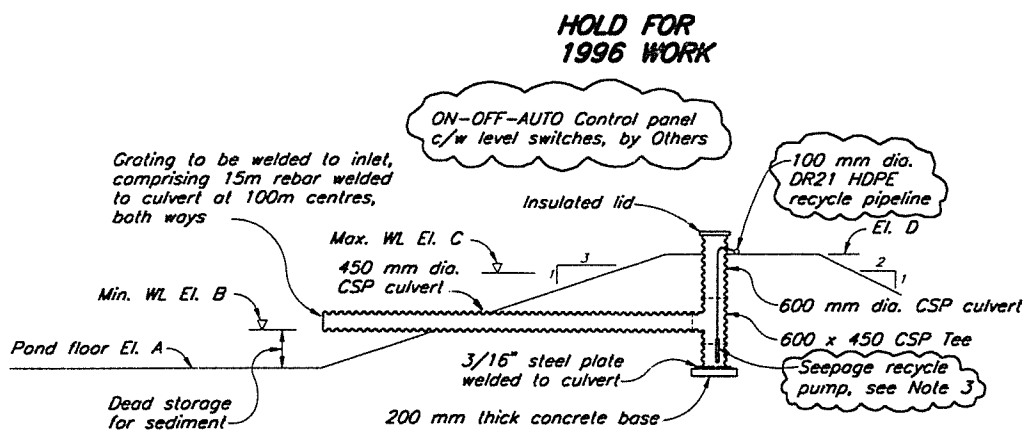

DETAIL 1625.113
SEEPAGE COLLECTION AND RECYCLE SYSTEM
Scale B

ELEVATION	MAIN EMBANKMENT	PERIMETER EMBANKMENT
A	908.0	925.0
B	908.5	926.0
C	909.5	927.5
D	911.0	930.0

NOTE

1. Test pits indicate 4m thickness of till in proposed location of barge channel. Additional test pits will be required to confirm adequate thickness of till to finalize barge channel alignment.
2. Compacted glacial till shall be placed along the barge channel excavation to meet basin liner requirements as directed by the Engineer.
3. Seepage recycle pump to be 4" electric submersible pump, discharging to 4" pipeline extended up D/S face of tailings embankment.
4. Wearing course required for Tailings Access Road and Bootjack-Morehead connector relocation only.

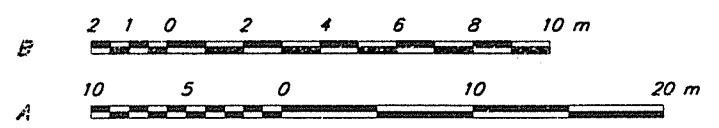

DRG. NO.	DESCRIPTION	REV.	DATE	DESCRIPTION	APPROVED
1625.113	TAILINGS STORAGE FACILITY - SEDIMENT CONTROL AND SEEPAGE COLLECTION - SECTIONS AND DETAILS				
1625.116	TAILINGS STORAGE FACILITY - TAILINGS DISTRIBUTION AND RECLAIM SYSTEM - PLAN AND PROFILE				

REV.	DATE	DESCRIPTION	APPROVED
1	MAY 26/95	ISSUED FOR DESIGN REPORT	KJB
0	APR. 6/95	ISSUED FOR REVIEW	

REV.	DATE	DESCRIPTION	APPROVED
1	MAY 26/95	ISSUED FOR DESIGN REPORT	KJB
0	APR. 6/95	ISSUED FOR REVIEW	

KNIGHT PIESOLD LIMITED
CONSULTING ENGINEERS - VANCOUVER, B.C.

DESIGNED: MBS
DRAWN: WY
CHECKED: WY
APPROVED: KJB

DATE: **APRIL 6, 1995**

IMPERIAL METALS CORPORATION

MT. POLLEY PROJECT

**TAILINGS STORAGE FACILITY
TAILINGS DISTRIBUTION AND
RECLAIM SYSTEM - SECTIONS AND DETAILS**

SCALE AS SHOWN
DRG. NO. **1625.117**
REV. **1**

CAD FILE: PROJECT/1625.116.DWG, 1:200 PLOT: 1-62 MAY 25, 1995

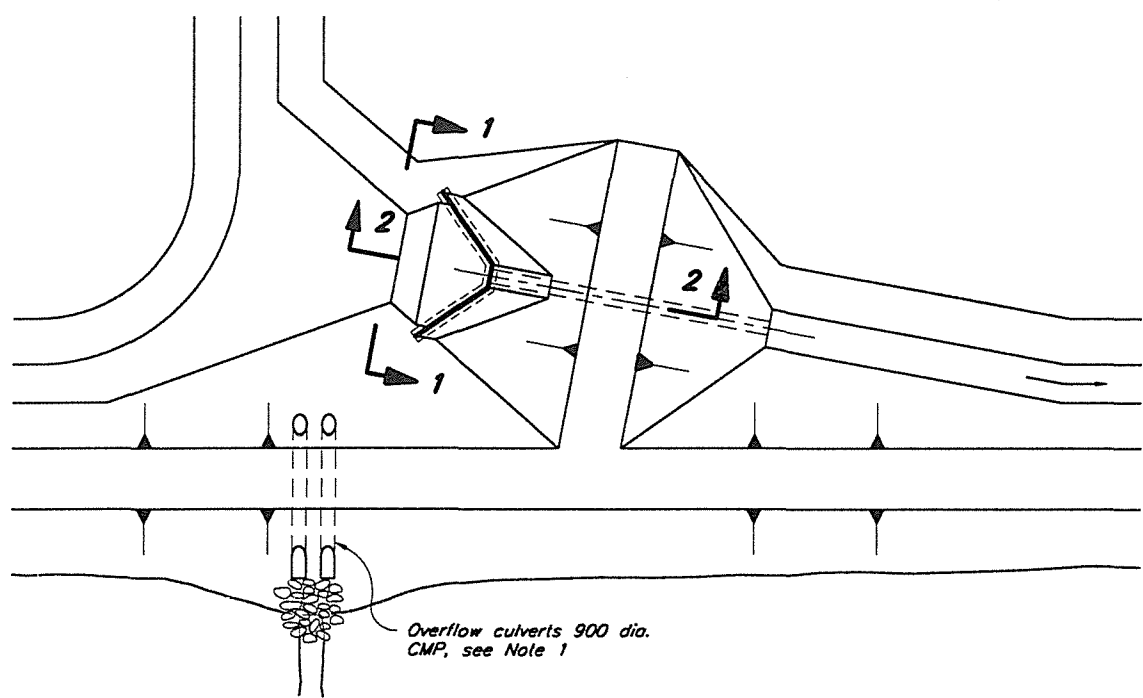

KEY PLAN
Scale A

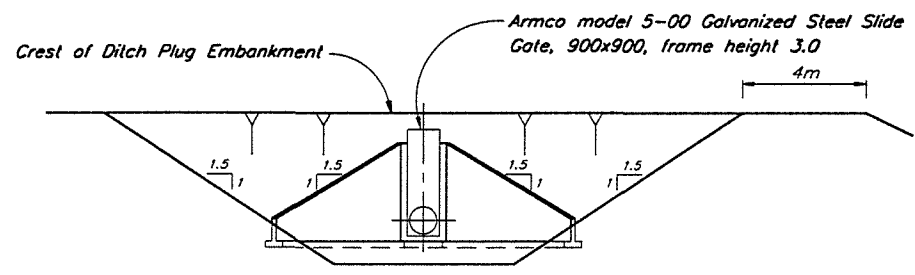

SECTION 1 - FRONT ELEVATION
Scale C

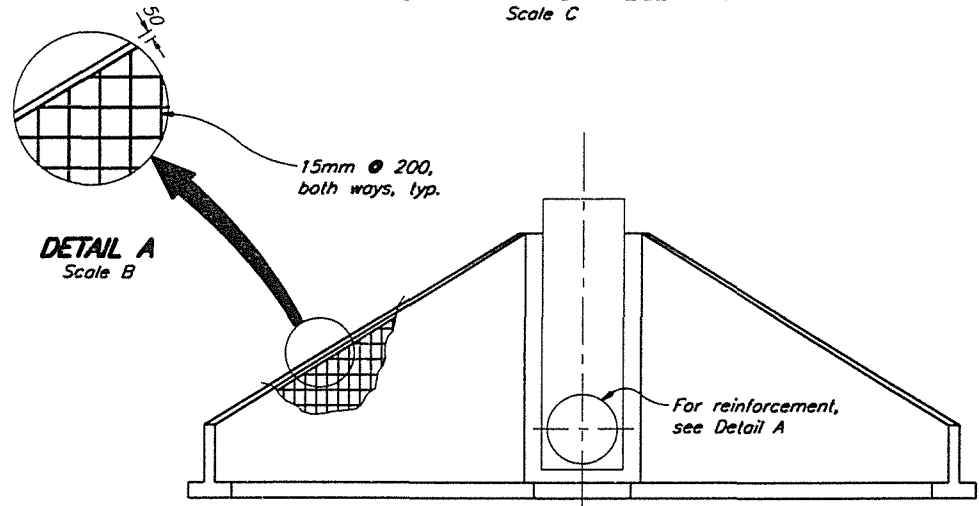

WALL REINFORCEMENT
Scale D

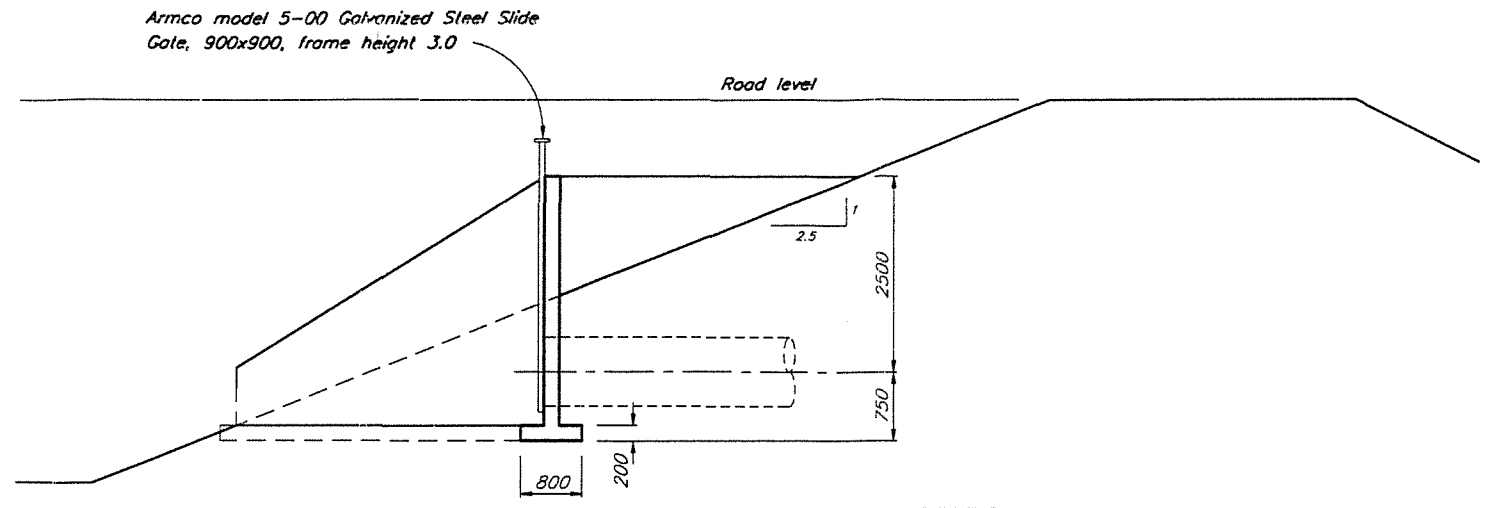

SECTION 2
Scale D

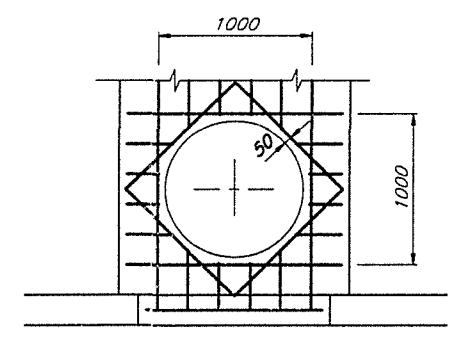

DETAIL A
CULVERT OPENING REINFORCEMENT
Scale B

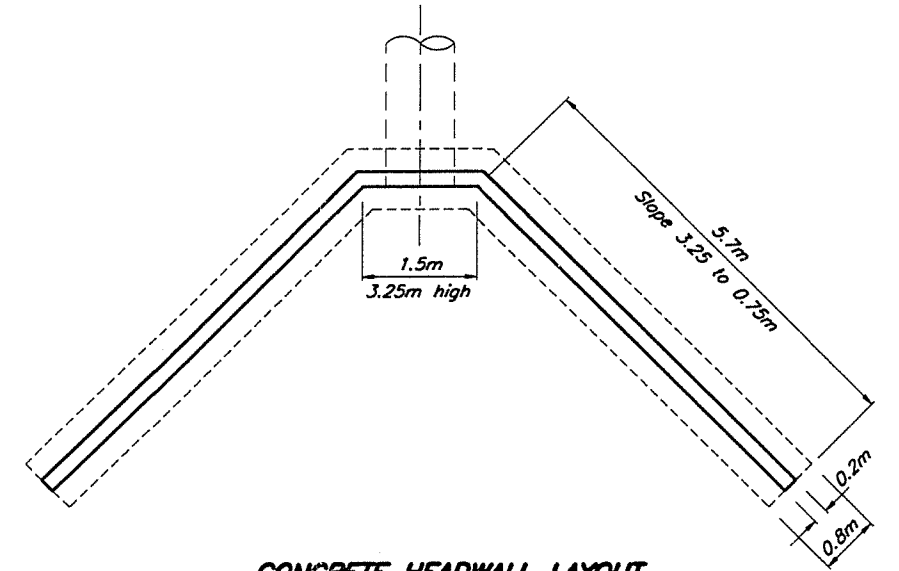

CONCRETE HEADWALL LAYOUT
Scale D

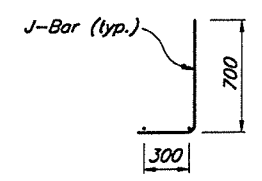

FOOTING REINFORCEMENT
Scale B

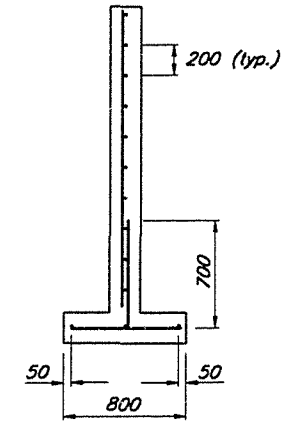

WALL REINFORCEMENT
Scale B

NOTE

- Flow control structures No. 1, 2 and 3 have 1 overflow culvert, No. 4 has 2 overflow culverts.

D	1	0	1	2	3	4	5	m
C	5	0	5	10				m
B	1	0.5	0	1	2			m
A	10	5	0	10	20			m

KNIGHT PIESOLD LIMITED
CONSULTING ENGINEERS - VANCOUVER, B.C.

DESIGNED: MBS
DRAWN: RDT/vy
CHECKED: [Signature]
APPROVED: [Signature]

DATE: **MAY 26, 1995**

IMPERIAL METALS CORPORATION

MT. POLLEY PROJECT

TAILINGS STORAGE FACILITY
SURFACE WATER CONTROL
FLOW CONTROL STRUCTURES
CONCRETE DETAILS

SCALE AS SHOWN
DRG. NO. **1625.118**
REV. **0**

DRG. NO.	DESCRIPTION	REV.	DATE	DESCRIPTION	APPROVED
	REFERENCE DRAWINGS				

REV.	DATE	DESCRIPTION	APPROVED
0	MAY 26/95	ISSUED FOR DESIGN REPORT	[Signature]

CAD FILE PROJECT 1625.03A.DWG 1:250 Plot 14-0:25 MAY 25, 1995

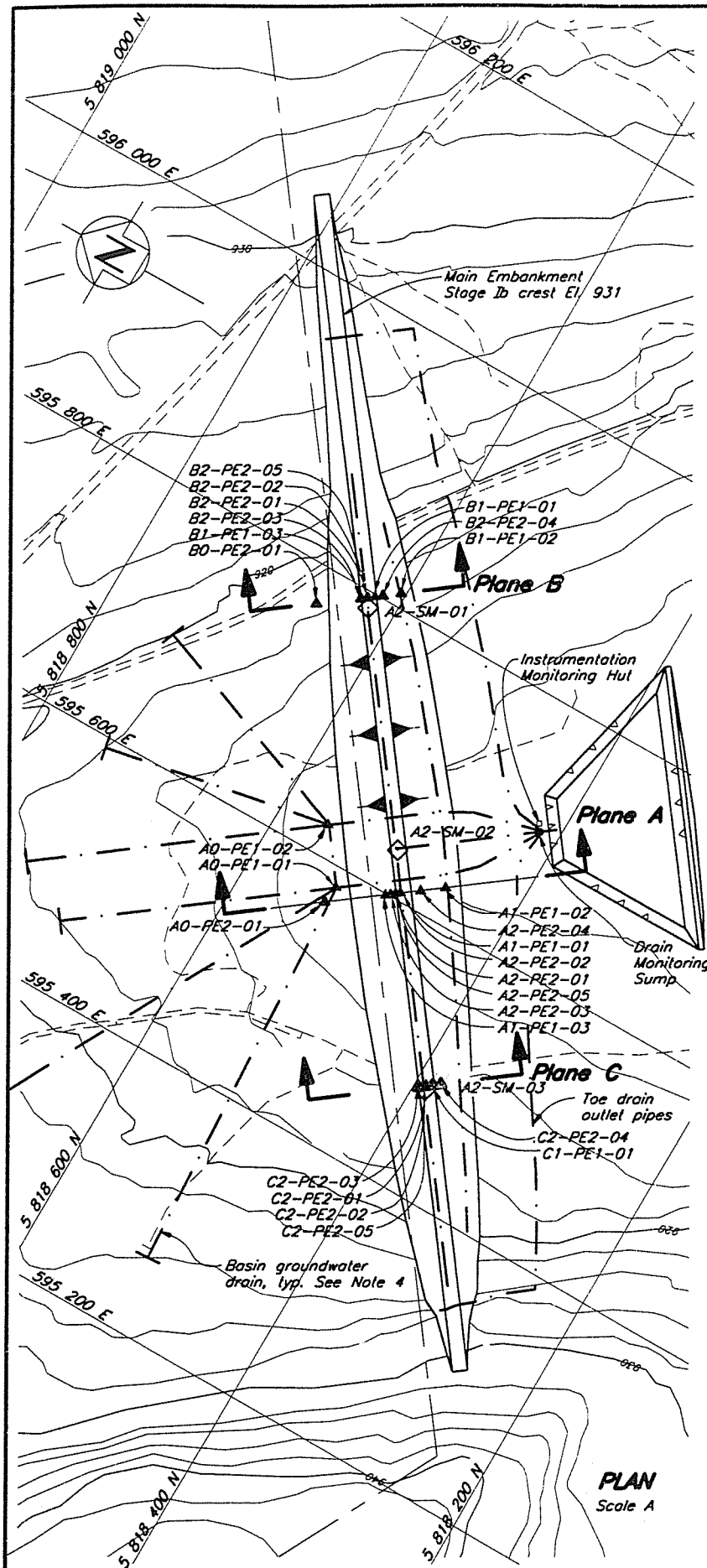

PLAN
Scale A

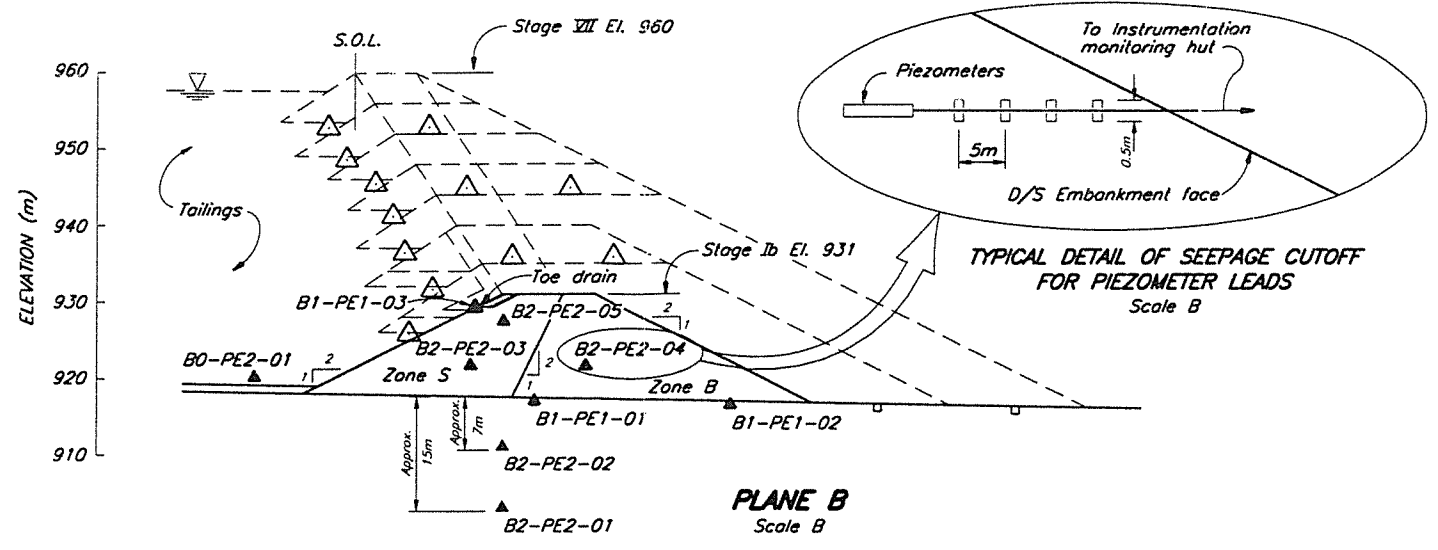

PLANE B
Scale B

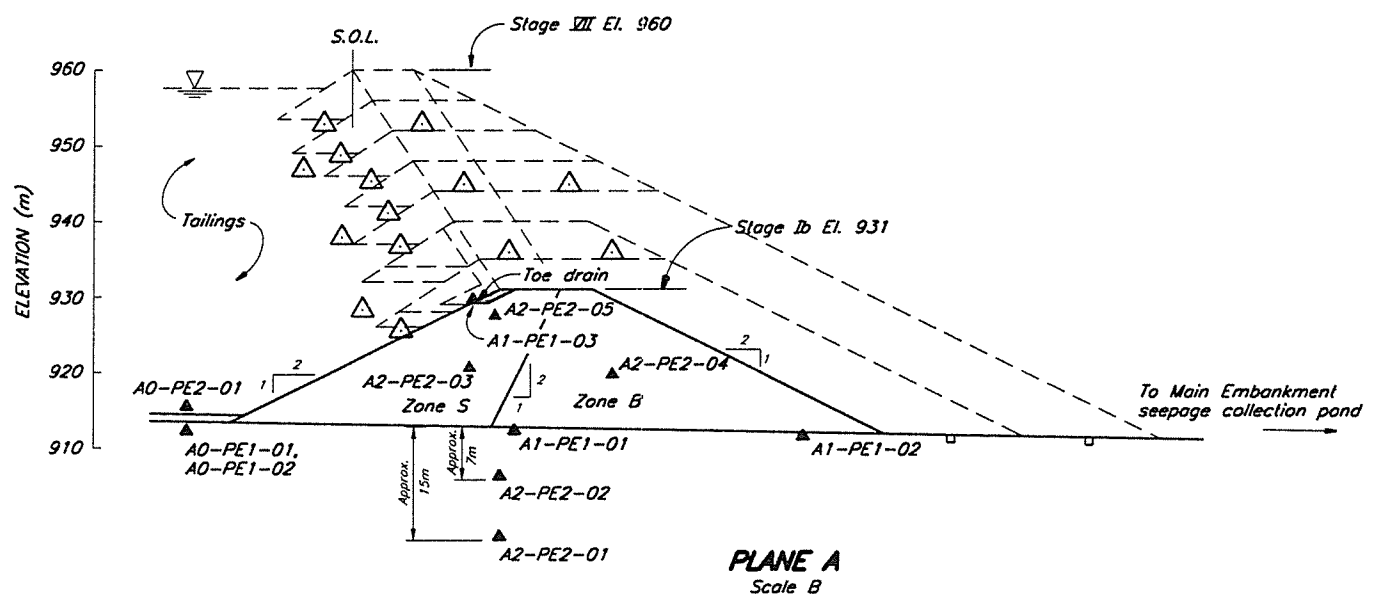

PLANE A
Scale B

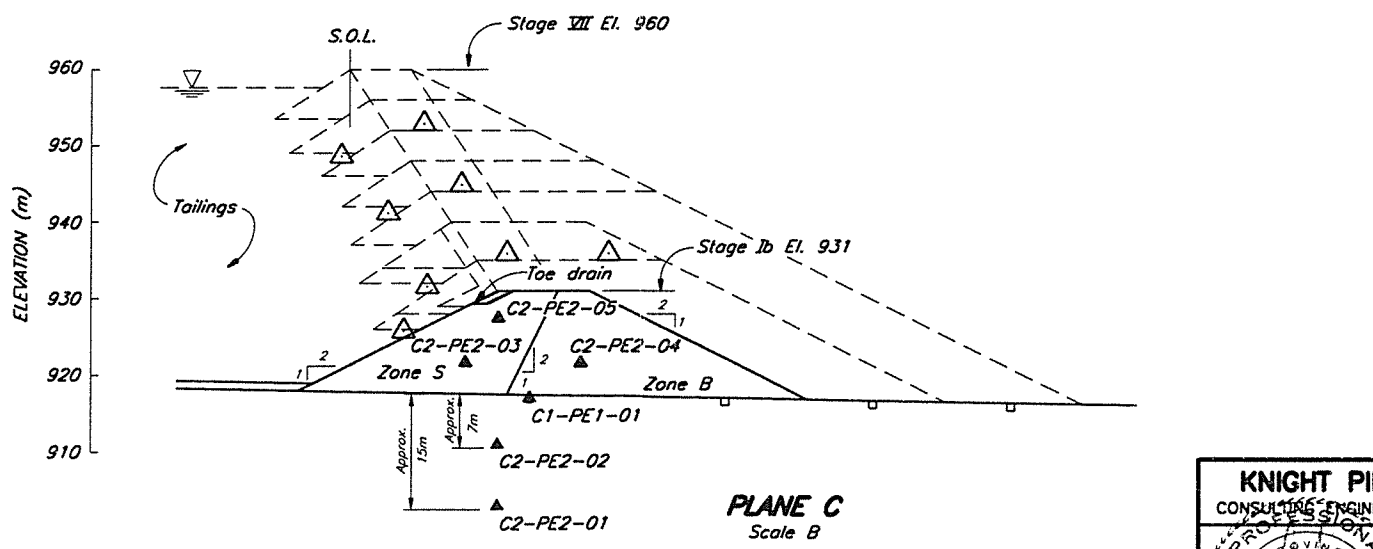

PLANE C
Scale B

NOTES

1. Piezometers are vibrating type, RST or equivalent, connected to a readout panel via heavy duty direct burial cable.
2. Piezometer leads are to be extended to a prefabricated monitoring hut located downstream of the final embankment toe.
3. A schedule required for piezometer types and lead lengths will be provided in the Technical Specifications.
4. Location of basin groundwater drain to be finalized in the field, based on exploration trenches.
5. Future survey monuments not shown. A minimum of 2 monuments will be installed for each embankment raise.

LEGEND

- Plane I.D. (A, B etc.)
 - Area (0-Tailings, 1-Drain, 2-Embankment)
 - A0-PE1-01—Number I.D.
 - Pressure Rating (1-Low, 2-High)
 - Type of Instrumentation (PE—Piezometer electric, SM—Survey Monument)
- A0-PE1-01 ▲ Tailings basin groundwater drain piezometer
 - A0-PE2-01 ▲ Tailings mass piezometer
 - A1-PE1-01 ▲ Embankment foundation drain and toe drain piezometer
 - A2-PE2-01 ▲ Embankment foundation and fill piezometer
 - A2-SM-01 ◊ Embankment survey monument
 - △ Future Piezometers

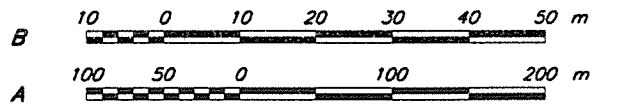

KNIGHT PIESOLD LIMITED
CONSULTING ENGINEERS - VANCOUVER, B.C.

DESIGNED GRG
DRAWN RDI/VV
CHECKED MS
APPROVED 213

IMPERIAL METALS CORPORATION

MT. POLLEY PROJECT

**TAILINGS STORAGE FACILITY
INSTRUMENTATION**

1	MAY 26/95	ISSUED FOR DESIGN REPORT	KJB
0	APR. 6/95	ISSUED FOR REVIEW	

DRG. NO.	DESCRIPTION	REV.	DATE	DESCRIPTION	APPROVED
	REFERENCE DRAWINGS			REVISIONS	

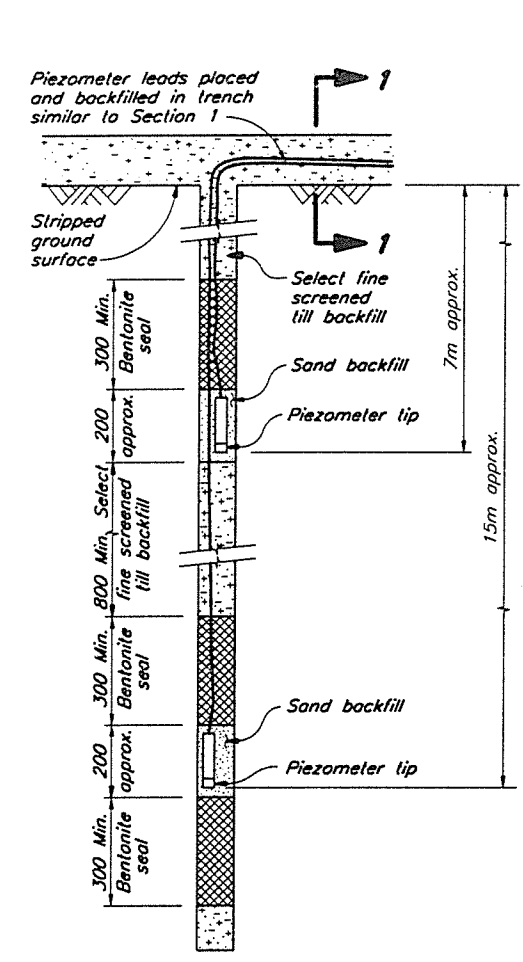

DETAIL A
INSTALLATION OF PIEZOMETERS
IN BOREHOLES
N.T.S.

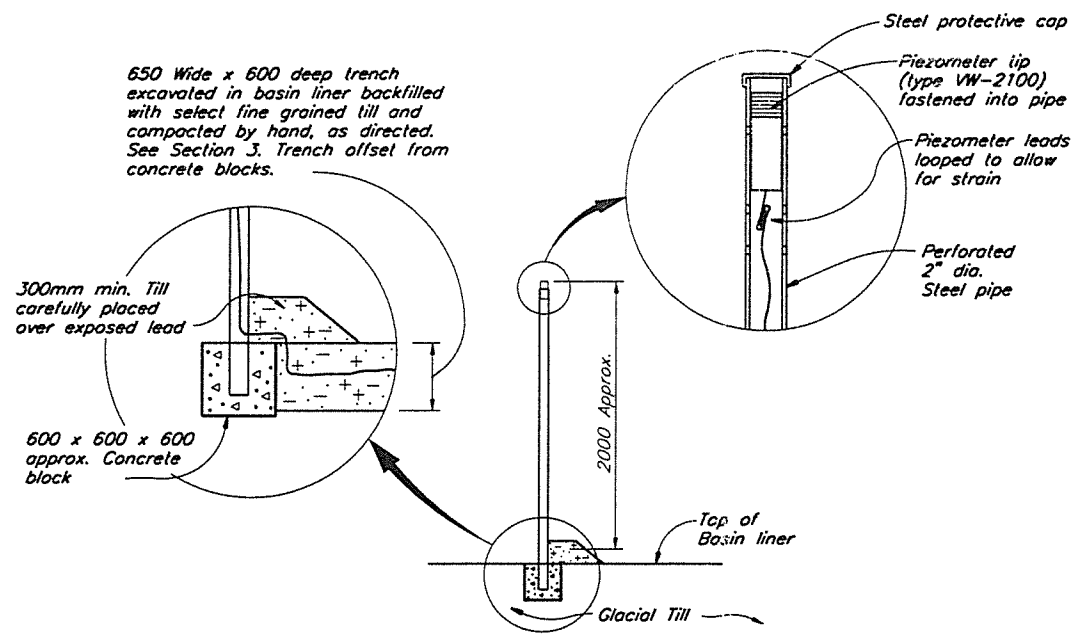

DETAIL B
VERTICAL SUPPORT FOR TAILINGS PIEZOMETERS
N.T.S.

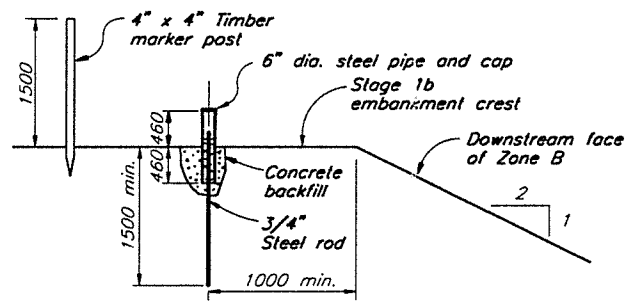

DETAIL OF
SURFACE MOVEMENT MONUMENT
N.T.S.

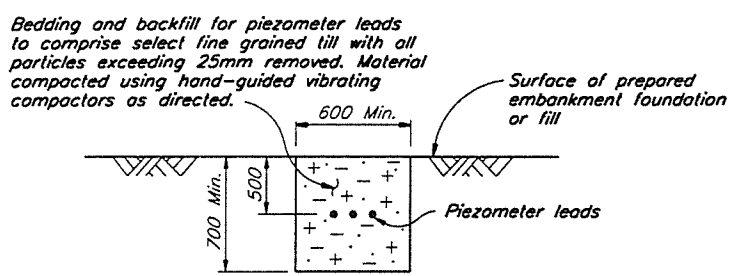

SECTION 1
TYPICAL SECTION THROUGH PIEZOMETER LEAD
TRENCH IN PREPARED EMBANKMENT FOUNDATION
OR IN ZONE S AND B FILL
N.T.S.

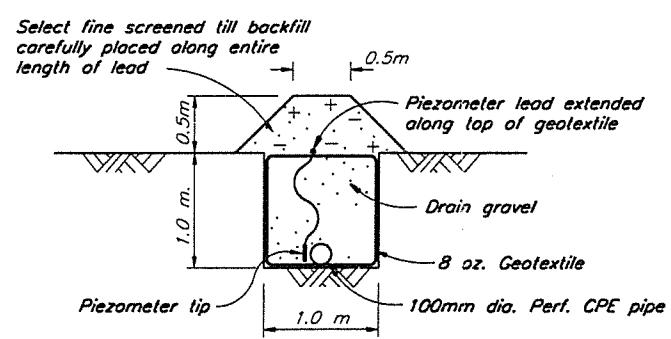

DETAIL C
TYPICAL PIEZOMETER INSTALLATION
IN BASIN GROUNDWATER DRAIN
OR EMBANKMENT FOUNDATION DRAIN
N.T.S.

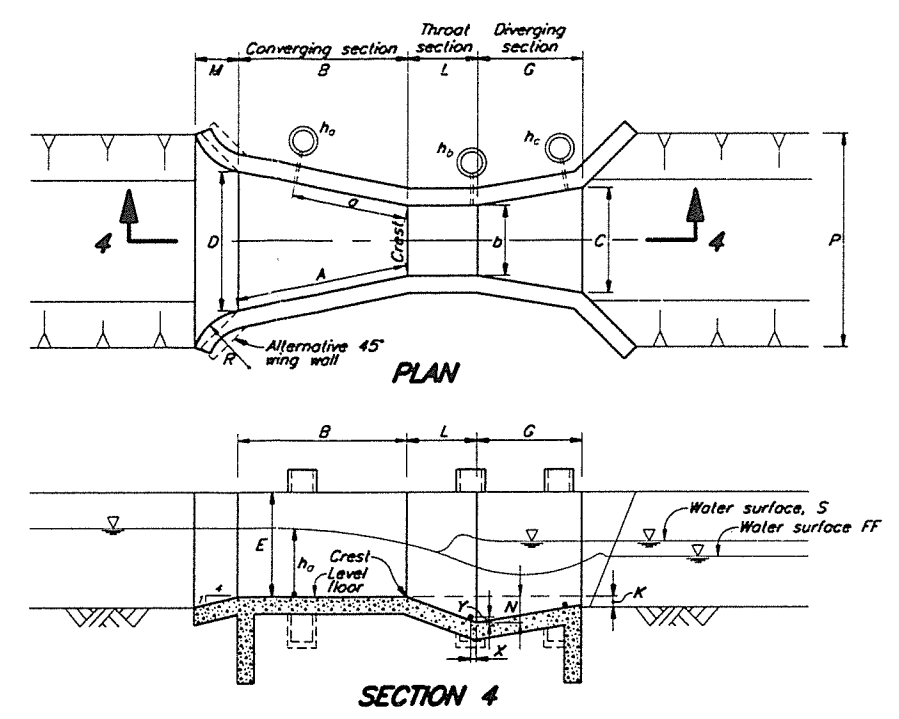

PARSHALL FLUME (2 FT. SIZE), DETAIL B/1625.114
FLOW MEASUREMENT FOR INFLOWS TO TAILINGS STORAGE FACILITY
AREA B RUNOFF COLLECTION AND TAILINGS AREA DIVERSION DITCHES

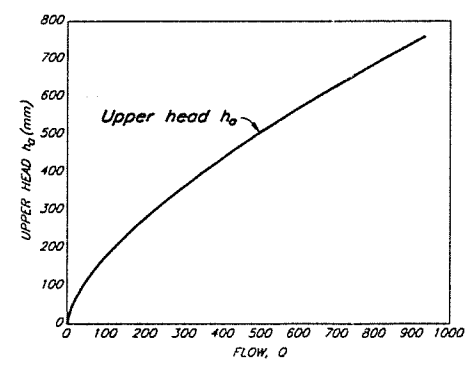

Dimensions for Parshall flume with throat width b_c of 2 feet.	
b_c	609.6
A	1524
a	1016
B	1495
C	914
D	1206
E	914
L	610
G	914
H	-
K	76
M	381
N	229
P	1854
R	508
X	51
Y	76
Z	-



KNIGHT PIESOLD LIMITED CONSULTING ENGINEERS - VANCOUVER, B.C. 	DESIGNED KDE/MBS	IMPERIAL METALS CORPORATION MT. POLLEY PROJECT TAILINGS STORAGE FACILITY INSTRUMENTATION SECTIONS AND DETAILS
	DRAWN BY CHECKED BY APPROVED BY	
DATE MAY 26, 1995	SCALE AS SHOWN	DRG. NO. 1625.121
REV. 0 MAY 26/95 ISSUED FOR DESIGN REPORT	APPROVED KJB	REV. 0

ORG. NO.	DESCRIPTION	REV.	DATE	DESCRIPTION	APPROVED
	REFERENCE DRAWINGS				
				REVISIONS	

CAP. FILE: PROJECT 1625.037.037 1:20 P&I 1-0-02 MAY 25, 1995

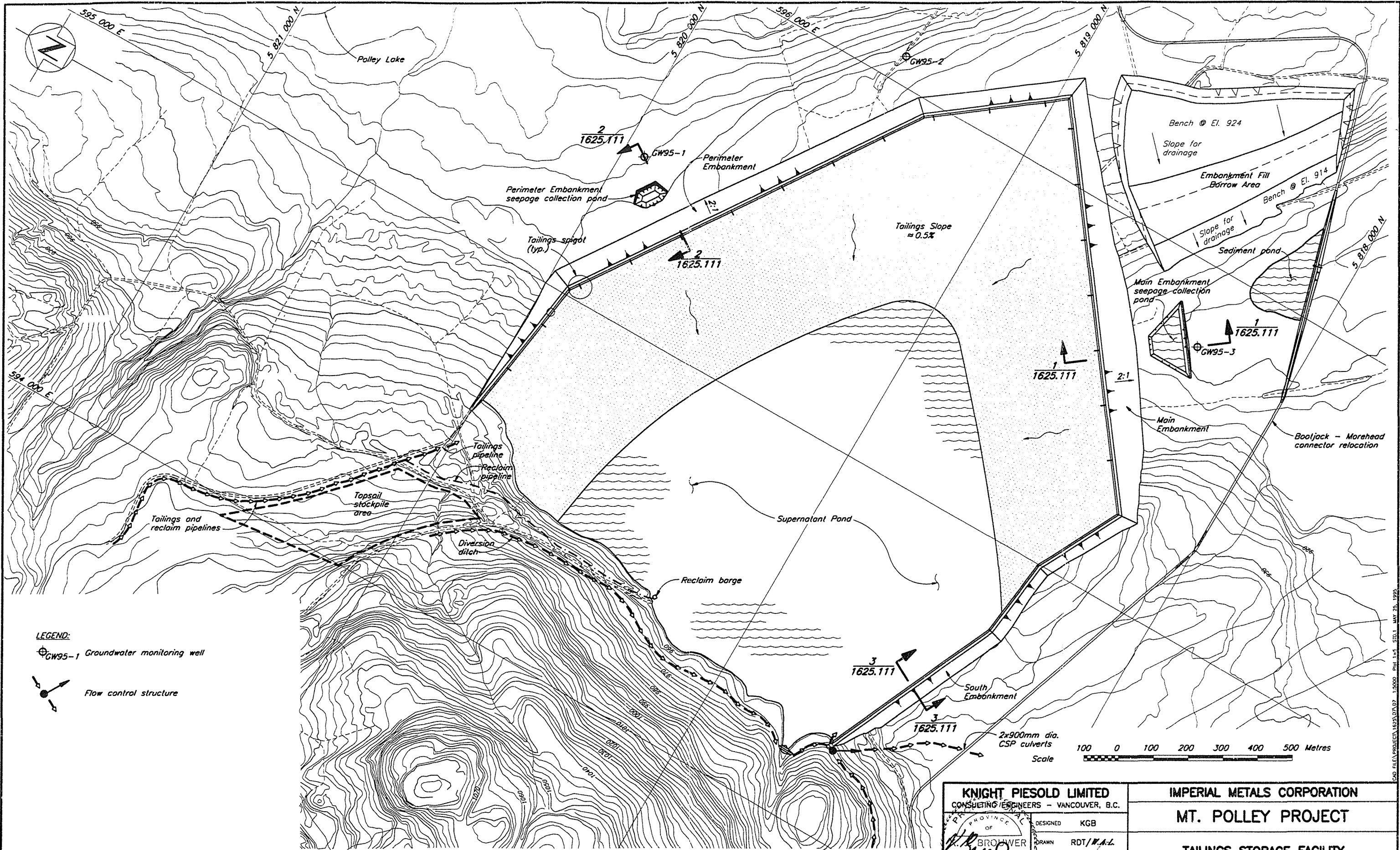

LEGEND:
 ⊕ GW95-1 Groundwater monitoring well
 ↗ Flow control structure

KNIGHT PIESOLD LIMITED
 CONSULTING ENGINEERS - VANCOUVER, B.C.

DESIGNED: KGB
 DRAWN: RDT/W.A.L.
 CHECKED: [Signature]
 APPROVED: [Signature]

PROVINCE OF BRITISH COLUMBIA
 ENGINEER

IMPERIAL METALS CORPORATION
MT. POLLEY PROJECT
TAILINGS STORAGE FACILITY
FINAL ARRANGEMENT

1625.111	TAILINGS STORAGE FACILITY - TAILINGS EMBANKMENT - SECTIONS AND DETAILS
ORG. NO.	DESCRIPTION
REV.	DATE
DESCRIPTION	APPROVED
REVISIONS	APPROVED

1	MAY 26/95	ISSUED FOR DESIGN REPORT	[Signature]
0	APR. 6/95	ISSUED FOR REVIEW	[Signature]
REV.	DATE	DESCRIPTION	APPROVED

1	MAY 26/95	ISSUED FOR DESIGN REPORT	[Signature]
0	APR. 6/95	ISSUED FOR REVIEW	[Signature]
REV.	DATE	DESCRIPTION	APPROVED

DATE **APRIL 6, 1995** SCALE AS SHOWN DRG. NO. **1625.130** REV. **1**

CAD FILE PROJECT 1625.DWG 1:1995 PLOT 1:1 1:1995 1625.130 MAY 25, 1995

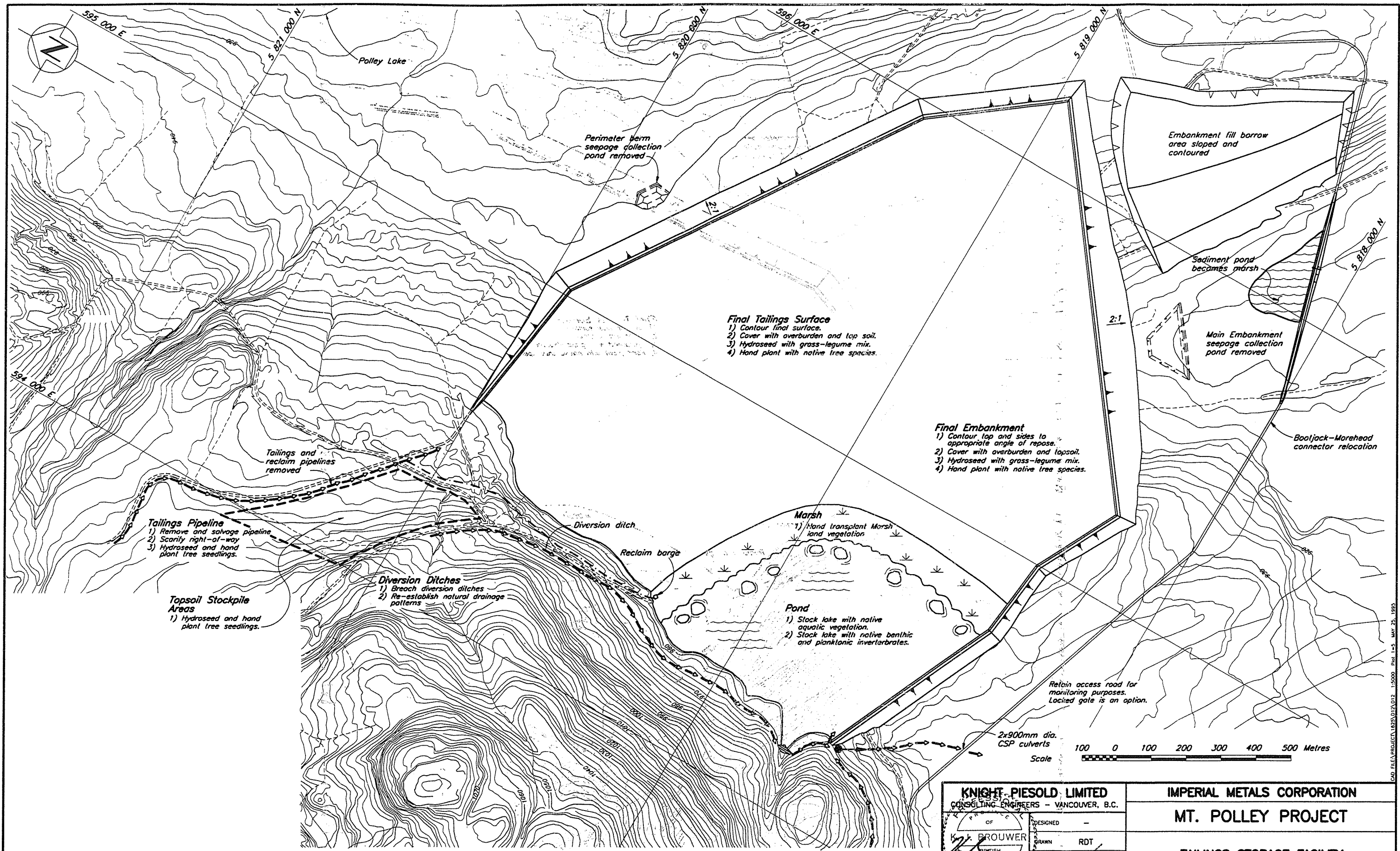

Final Tailings Surface
 1) Contour final surface.
 2) Cover with overburden and top soil.
 3) Hydroseed with grass-legume mix.
 4) Hand plant with native tree species.

Final Embankment
 1) Contour top and sides to appropriate angle of repose.
 2) Cover with overburden and topsoil.
 3) Hydroseed with grass-legume mix.
 4) Hand plant with native tree species.

Tailings Pipeline
 1) Remove and salvage pipeline.
 2) Scarify right-of-way.
 3) Hydroseed and hand plant tree seedlings.

Topsoil Stockpile Areas
 1) Hydroseed and hand plant tree seedlings.

Diversion Ditches
 1) Breach diversion ditches.
 2) Re-establish natural drainage patterns.

Marsh
 1) Hand transplant Marsh land vegetation.

Pond
 1) Stock lake with native aquatic vegetation.
 2) Stock lake with native benthic and planktonic invertebrates.

Retain access road for monitoring purposes. Locked gate is an option.

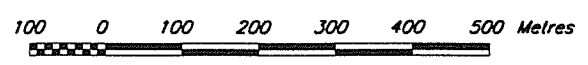

KNIGHT-PIESOLD LIMITED
 CONSULTING ENGINEERS - VANCOUVER, B.C.

DESIGNED: —
 DRAWN: RDT
 CHECKED: [Signature]
 APPROVED: [Signature]

OF [Signature] BROWER
 BRITISH COLUMBIA
 ENGINEER

IMPERIAL METALS CORPORATION	
MT. POLLEY PROJECT	
TAILINGS STORAGE FACILITY RECLAMATION PLAN	
DATE MAR. 31, 1995	SCALE AS SHOWN
DRG. NO. 1625.140	REV. 1

DRG. NO.	DESCRIPTION	REV.	DATE	DESCRIPTION	APPROVED
	REFERENCE DRAWINGS				
	REVISIONS				

REV.	DATE	DESCRIPTION	APPROVED
1	MAY 26/95	ISSUED FOR DESIGN REPORT	[Signature]
0	APR. 6/95	ISSUED FOR REVIEW	[Signature]

CAD FILE: PROJECT 1625.012.DWG 1:5000 Plot 1-5 MAY 25, 1995